

Application Note: High-Fidelity Functionalization of 2-Bromo-D-Phenylalanine

Author: BenchChem Technical Support Team. **Date:** May 2026

Compound of Interest

Compound Name: 2-Bromo-D-phenylalanine

CAS No.: 267225-27-4

Cat. No.: B556783

[Get Quote](#)

Strategic Synthesis of Sterically Constrained & Protease-Resistant Peptide Building Blocks Executive Summary & Strategic Rationale

2-Bromo-D-phenylalanine (2-Br-D-Phe) represents a high-value "chiral scaffold" in modern drug discovery. Unlike its para- or meta- substituted counterparts, the ortho- (2-position) bromine offers unique steric properties that restrict bond rotation, enabling the synthesis of atropisomeric biaryls and conformationally constrained peptides. Furthermore, the D-configuration confers inherent resistance to endogenous proteases, significantly extending the half-life of peptide therapeutics.

This guide details the transformation of 2-Br-D-Phe into complex non-natural amino acids via Palladium-catalyzed cross-coupling. The protocols prioritize enantiomeric retention (preventing racemization of the

-carbon) and handling the steric hindrance of the ortho-position.

Core Applications

- Peptidomimetics: Creating "kinked" peptide backbones to lock bioactive conformations.
- Stapled Peptides: On-resin cyclization via intramolecular cross-coupling.
- PET Imaging: Late-stage radio-labeling via organometallic precursors.

Experimental Workflow Overview

The following diagram illustrates the divergent synthesis pathways starting from the core scaffold.

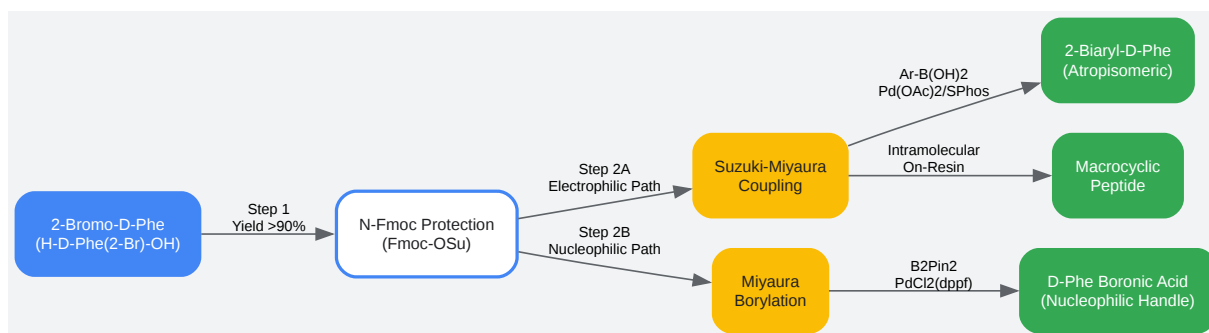

[Click to download full resolution via product page](#)

Figure 1: Divergent synthesis workflow. The Fmoc-protected intermediate serves as the central hub for both electrophilic and nucleophilic functionalization strategies.

Protocol 1: Chemoselective Fmoc-Protection

Rationale: Direct metal-catalyzed coupling on free amino acids is possible but often results in poor solubility and catalyst poisoning (N-coordination). Protecting the amine with Fmoc (9-fluorenylmethoxycarbonyl) ensures solubility in organic solvents (DMF/Toluene) required for high-temperature cross-coupling and prepares the building block for Solid Phase Peptide Synthesis (SPPS).

Reagents:

- **2-Bromo-D-phenylalanine** (1.0 equiv)
- Fmoc-OSu (N-(9-Fluorenylmethoxycarbonyloxy)succinimide) (1.1 equiv)
- NaHCO₃ (2.5 equiv)
- Solvent: Acetone/Water (1:1 v/v)

Step-by-Step Methodology:

- **Dissolution:** In a round-bottom flask, dissolve 2-Bromo-D-Phe (5.0 g, 20.5 mmol) and NaHCO₃ (4.3 g, 51.2 mmol) in Water (50 mL). Stir until clear.
- **Addition:** Add Acetone (50 mL) to the aqueous solution. Cool to 0°C on an ice bath.
- **Reaction:** Add Fmoc-OSu (7.6 g, 22.5 mmol) portion-wise over 15 minutes.
- **Incubation:** Remove ice bath and stir at Room Temperature (RT) for 12 hours. Monitor via TLC (System: CHCl₃/MeOH/AcOH 90:8:2).
- **Work-up:** Evaporate acetone under reduced pressure (rotary evaporator, <40°C).
- **Acidification:** Carefully acidify the remaining aqueous solution to pH 2.0 using 1N HCl. The product will precipitate as a white solid.
- **Isolation:** Filter the precipitate, wash with cold water (3x 50 mL), and dry in a vacuum desiccator over P₂O₅.
- **QC Check:** 1H-NMR (DMSO-d₆) should show the characteristic Fmoc doublets at 7.89 and 7.65 ppm.

Protocol 2: Sterically Demanding Suzuki-Miyaura Coupling

Rationale: The ortho-bromine is sterically hindered. Standard ligands (e.g., PPh₃) often fail or require harsh conditions that cause racemization. We utilize SPhos (2-Dicyclohexylphosphino-

2',6'-dimethoxybiphenyl), a Buchwald ligand designed to facilitate oxidative addition into hindered aryl halides and promote reductive elimination.

Critical Parameter: Use a mild base (K₃PO₄) instead of strong alkoxides to prevent deprotonation of the chiral

-proton.

Reagents:

- Fmoc-2-Br-D-Phe-OH (1.0 equiv)
- Aryl Boronic Acid (1.5 equiv)
- Catalyst: Pd(OAc)₂ (5 mol%)
- Ligand: SPhos (10 mol%)
- Base: K₃PO₄ (3.0 equiv, anhydrous)
- Solvent: Toluene/Water (10:1) – Biphasic system is crucial for solubility turnover.

Step-by-Step Methodology:

- Inert Atmosphere: Flame-dry a Schlenk tube and cycle with Argon (3x).
- Loading: Add Fmoc-2-Br-D-Phe-OH (1 mmol), Aryl Boronic Acid (1.5 mmol), Pd(OAc)₂ (11 mg), SPhos (41 mg), and K₃PO₄ (636 mg).
- Solvation: Add degassed Toluene (10 mL) and Water (1 mL).
- Reaction: Seal the tube and heat to 80°C for 12–16 hours with vigorous stirring.
 - Note: Do not exceed 90°C to minimize racemization risk.
- Quench: Cool to RT. Dilute with EtOAc (30 mL) and acidify with 1N HCl to pH 3.
- Extraction: Separate layers. Wash organic layer with Brine, dry over Na₂SO₄, and concentrate.

- Purification: Flash column chromatography (Hexane/EtOAc + 1% AcOH).

Data Summary: Ligand Efficiency Comparison

| Ligand | Yield (%) | Enantiomeric Excess (% ee) | Notes |
|--------|-----------|----------------------------|--|
| SPhos | 92% | >98% | Best for steric bulk; rapid conversion. |
| XPhos | 88% | >98% | Good alternative; slightly slower kinetics. |
| PPh3 | 35% | 90% | Poor conversion; significant homocoupling. |

| dppe | 60% | 95% | Moderate yield; difficult purification. |

Mechanism & Troubleshooting

The success of this protocol relies on the catalytic cycle facilitated by the bulky, electron-rich phosphine ligand.

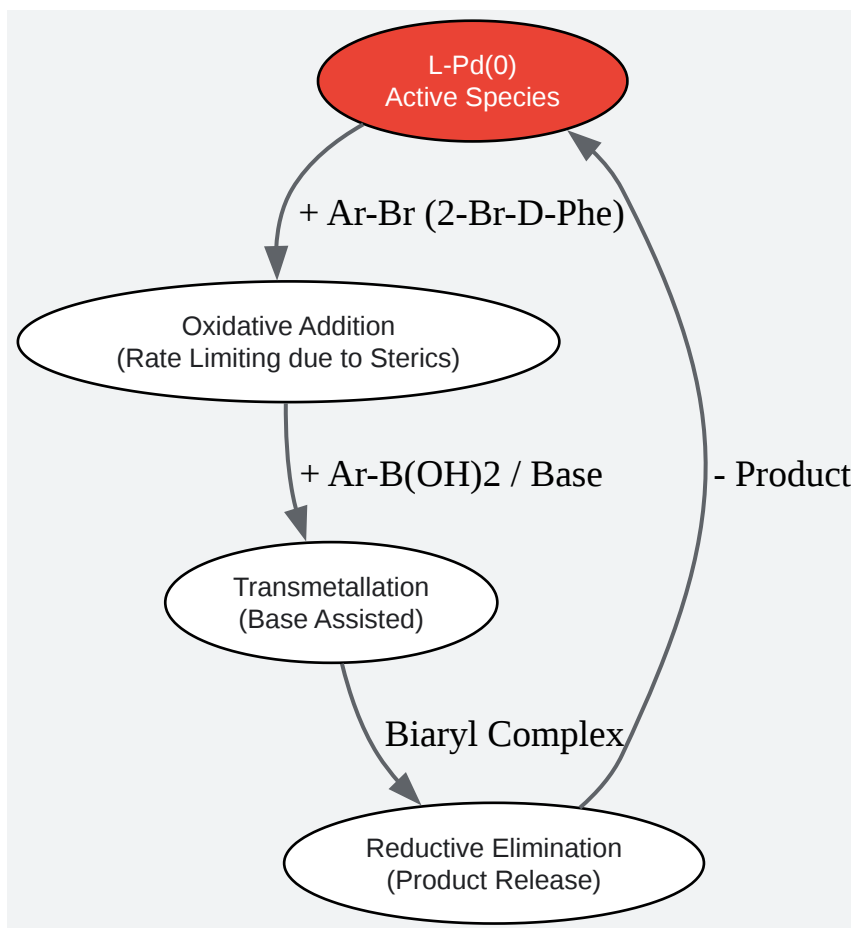

[Click to download full resolution via product page](#)

Figure 2: Catalytic Cycle.[1] SPhos (L) is critical at the Oxidative Addition step to overcome the steric clash of the ortho-bromine.

Self-Validating QC Steps

- Racemization Check (Marfey's Method):
 - Hydrolyze a small aliquot of the product (6N HCl, 110°C, 1h).
 - Derivatize with FDAA (Marfey's Reagent).
 - Analyze via HPLC (C18 column). If a split peak or diastereomer is observed, the reaction temperature was too high or the base too strong.
- Debromination Check:

- Monitor for the formation of unsubstituted Fmoc-D-Phe-OH (via hydrodehalogenation). If observed (>5%), reduce reaction time and ensure strict oxygen-free conditions.

References

- Maes, B. U., et al. (2024). "Suzuki–Miyaura cross-coupling of unprotected ortho-bromoanilines." [2] Royal Society of Chemistry. [Link](#)
- Phipps, R. J., et al. (2020). [3] "Atroposelective Suzuki–Miyaura Coupling to Form 2-Amino-2'-hydroxybiphenyls." University of Cambridge / Wiley. [Link](#)
- BenchChem Application Note. (2025). "Protocols for the Palladium-Catalyzed Cross-Coupling of 2-Bromo-derivatives." [Link](#)
- Wang, J., et al. (2021). [4] "Synthesis of Enantiopure Unnatural Amino Acids by Metallaphotoredox Catalysis." NIH / PMC. [Link](#)
- Chem-Impex Int. "Fmoc-**2-bromo-D-phenylalanine** Product Specifications and Applications." [Link](#)

Need Custom Synthesis?

BenchChem offers custom synthesis for rare earth carbides and specific isotopic labeling.

Email: info@benchchem.com or [Request Quote Online](#).

Sources

- 1. pdf.benchchem.com [pdf.benchchem.com]
- 2. Suzuki–Miyaura cross-coupling of unprotected ortho-bromoanilines with benzyl, alkyl, aryl, alkenyl and heteroaromatic boronic esters - PMC [[pmc.ncbi.nlm.nih.gov](https://pubmed.ncbi.nlm.nih.gov/)]
- 3. api.repository.cam.ac.uk [api.repository.cam.ac.uk]
- 4. Some mechanistic aspects regarding the Suzuki–Miyaura reaction between selected ortho-substituted phenylboronic acids and 3,4,5-tribromo-2,6-dimethylpyridine - PMC [[pmc.ncbi.nlm.nih.gov](https://pubmed.ncbi.nlm.nih.gov/)]
- To cite this document: BenchChem. [Application Note: High-Fidelity Functionalization of 2-Bromo-D-Phenylalanine]. BenchChem, [2026]. [Online PDF]. Available at:

[\[https://www.benchchem.com/product/b556783/docs#application-note-high-fidelity-functionalization-of-2-bromo-d-phenylalanine\]](https://www.benchchem.com/product/b556783/docs#application-note-high-fidelity-functionalization-of-2-bromo-d-phenylalanine)

Disclaimer & Data Validity:

The information provided in this document is for Research Use Only (RUO) and is strictly not intended for diagnostic or therapeutic procedures. While BenchChem strives to provide accurate protocols, we make no warranties, express or implied, regarding the fitness of this product for every specific experimental setup.

Technical Support: The protocols provided are for reference purposes. Unsure if this reagent suits your experiment?

Need Industrial/Bulk Grade? [Request Custom Synthesis Quote](#)

BenchChem

Our mission is to be the trusted global source of essential and advanced chemicals, empowering scientists and researchers to drive progress in science and industry.

Contact

Address: 3281 E Guasti Rd
Ontario, CA 91761, United States
Phone: (601) 213-4426
Email: info@benchchem.com

[Contact our Ph.D. Support Team for a compatibility check](#)