

A Senior Application Scientist's Guide to Proline Analogs in Protein Engineering

Author: BenchChem Technical Support Team. **Date:** May 2026

Compound of Interest

| | |
|----------------|----------------------------------|
| Compound Name: | 2-Azetidinecarboxylic acid, (S)- |
| CAS No.: | 2133-34-8 |
| Cat. No.: | B555074 |

[Get Quote](#)

Introduction: The Unique Role of Proline and the Rationale for Analogs

Among the twenty proteinogenic amino acids, proline is unique. Its side chain loops back to form a covalent bond with its own backbone amide nitrogen, creating a rigid five-membered pyrrolidine ring.^{[1][2]} This cyclic structure imposes significant conformational constraints on the polypeptide backbone, restricting the dihedral angle ϕ to a narrow range and disrupting secondary structures like α -helices and β -sheets.^{[2][3][4]} Furthermore, the peptide bond preceding a proline residue (the Xaa-Pro bond) has a uniquely low energy barrier to cis-trans isomerization, meaning a significant population of cis conformers can exist in proteins, a state that is energetically unfavorable for other peptide bonds.^[3] This isomerization is often a rate-limiting step in protein folding.^{[3][5]}

While these properties make proline a critical residue for defining protein architecture, particularly in turns and loops, they also present a tantalizing target for protein engineers. Standard site-directed mutagenesis, which replaces proline with one of the other 19 canonical amino acids, invariably disrupts these unique backbone constraints.^{[2][6]} Proline analogs, or non-canonical prolines (ncPros), offer a more nuanced approach. By introducing subtle

chemical modifications to the proline ring, we can perform "molecular surgery" on the protein backbone.[6][7] This allows us to systematically modulate conformational preferences, enhance stability, accelerate folding, and introduce novel functionalities, providing powerful tools for both fundamental research and the development of protein-based therapeutics.[8][9][10]

This guide provides a comparative analysis of the most impactful proline analogs used in protein engineering, detailing their mechanisms of action and providing the experimental frameworks necessary for their successful application.

The Conformational Logic: Ring Pucker and Amide Isomerization

The functional consequences of incorporating a proline analog are primarily dictated by how it influences two key interrelated properties: the puckering of the pyrrolidine ring and the cis/trans isomerism of the preceding amide bond. The proline ring is not planar and rapidly interconverts between two predominant puckered conformations: Cy-endo (where Cy is on the same side of the ring as the carboxyl group) and Cy-exo (where it is on the opposite side).[2] Crucially, the ring pucker is coupled to the amide bond conformation: an exo pucker stabilizes a trans amide bond, while an endo pucker is strongly favored in a cis amide bond.[5] By installing substituents on the ring, we can stereoelectronically bias this equilibrium to favor one state over the other.

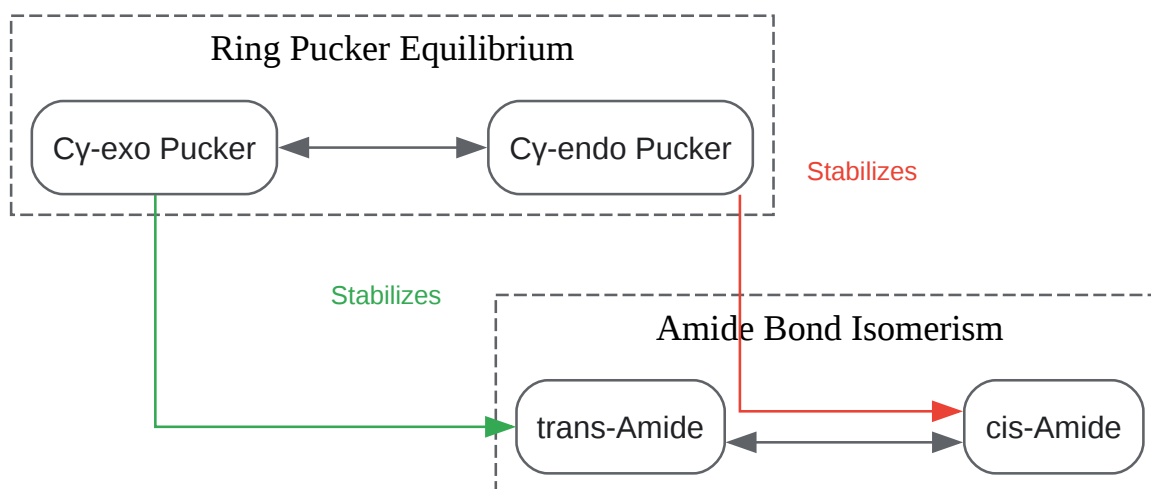

[Click to download full resolution via product page](#)

Caption: Relationship between proline ring pucker and amide bond conformation.

A Comparative Analysis of Key Proline Analogs

Here we compare several classes of proline analogs, focusing on how their unique chemistries translate into predictable effects on protein structure and function.

Fluoroprolines: The Stereoelectronic Scalpel

Fluorinated prolines are perhaps the most widely used analogs for precise conformational control. The high electronegativity of the fluorine atom creates a powerful inductive effect that, depending on its stereochemistry at the C4 position, can lock the ring into a preferred pucker via the gauche effect.^{[11][12]}

- (4S)-fluoroproline (S-Flp): The fluorine atom at the 4S position preferentially stabilizes the Cy-endo pucker. This, in turn, strongly favors the cis conformation of the preceding amide bond.^{[6][12]}
- (4R)-fluoroproline (R-Flp): Conversely, fluorine at the 4R position stabilizes the Cy-exo pucker, promoting the trans amide conformation.^{[5][6][13]}

Causality in Action: If a target proline residue exists in a native trans conformation, replacing it with R-Flp can significantly enhance the protein's thermal stability.^{[13][14]} In contrast, replacing it with S-Flp would create a conformational clash, likely leading to destabilization or misfolding.^{[6][7]} This predictable behavior makes fluoroprolines exceptional tools for probing and reinforcing native protein structures.^{[13][15]} Furthermore, the fluorine atom serves as a sensitive ¹⁹F NMR probe for studying protein dynamics and interactions without perturbing the system with bulky labels.^{[2][16]}

4-Hydroxyproline (Hyp): Nature's Stabilizer

trans-4-hydroxyproline (Hyp) is a natural post-translational modification abundant in collagen, where it is essential for the stability of the triple helix.^{[17][18][19]}

- Mechanism of Action: Similar to R-Flp, the electronegative hydroxyl group in the trans (4R) position stabilizes the Cy-exo pucker, which preorganizes the polypeptide backbone for efficient triple helix formation.^[14] This stereoelectronic effect, combined with the potential for hydrogen bonding, makes Hyp a powerful stabilizing agent.^[18]

- Impact and Applications: Incorporating Hyp into recombinant collagen-like proteins dramatically increases their thermal stability (T_m).[\[18\]](#) This strategy is widely used in biomaterial engineering to create stable, synthetic extracellular matrix components for tissue engineering and drug delivery applications.[\[20\]](#)

Thioprolinone (Thz): The Folding Accelerator

Thioprolinone (1,3-thiazolidine-4-carboxylic acid), where the α carbon is replaced by a sulfur atom, has a profound effect on the kinetics of protein folding.[\[21\]](#)[\[22\]](#)

- Mechanism of Action: The presence of the larger, more polarizable sulfur atom alters the ring's geometry and electronics. This has two key consequences: it slightly increases the intrinsic population of the cis-amide isomer compared to proline, and more importantly, it significantly lowers the activation energy barrier for cis-trans isomerization.[\[11\]](#)[\[23\]](#)
- Impact and Applications: For proteins whose folding is rate-limited by the isomerization of a cis-proline in the native state, substitution with Thz can be transformative. It has been shown to accelerate the slow folding phase by up to two orders of magnitude.[\[11\]](#) This makes Thz an invaluable tool for studying the mechanisms of protein folding and for engineering proteins where rapid folding is desirable. Its inherent antioxidant properties also offer a route to designing proteins with enhanced resistance to oxidative stress.[\[11\]](#)[\[22\]](#)

Ring-Size Variants: Probing Conformational Boundaries

- Azetidino-2-carboxylic acid (Aze): This analog features a smaller, four-membered ring. This increased ring strain further constrains the backbone, but often in a manner that is incompatible with stable protein folds.[\[8\]](#) Its incorporation is frequently toxic and leads to protein misfolding.[\[19\]](#) While not typically used for stabilization, Aze serves as a powerful biochemical probe to investigate the structural tolerance of a protein to backbone perturbations.[\[8\]](#)[\[19\]](#)
- α -Methylproline (α MePro): The addition of a methyl group to the α -carbon introduces significant steric hindrance that further restricts backbone flexibility.[\[3\]](#)[\[24\]](#) This modification strongly disfavors the cis-amide conformation and can be used to rigidly enforce a trans peptide bond or to stabilize specific turn structures in peptide design.[\[23\]](#)[\[24\]](#)

| Proline Analog | Ring Pucker Preference | Effect on Xaa-Pro Bond | General Impact on Stability | Primary Applications |
|-----------------------------|------------------------|----------------------------------|---|---|
| (4R)-Fluoroproline | Cy-exo | Favors trans | Stabilizes native trans-prolines[13] | Enhancing thermal stability, ¹⁹ F NMR[16] |
| (4S)-Fluoroproline | Cy-endo | Favors cis | Stabilizes native cis-prolines[7] | Probing folding, accelerating refolding[7] |
| trans-4-Hydroxyproline | Cy-exo | Favors trans | Strongly stabilizes (esp. collagen)[14][18] | Biomaterial engineering, collagen design |
| Thioprolinone | N/A | Lowers isomerization barrier[11] | Can destabilize, but accelerates folding | Studying folding kinetics, antioxidant proteins[11][22] |
| Azetidine-2-Carboxylic Acid | Highly Strained | Distorts backbone | Generally destabilizing and toxic[19] | Probing structural tolerance |
| α -Methylproline | N/A | Strongly favors trans | Enforces specific conformations | Peptide design, β -turn mimetics[24] |

Experimental Workflows and Protocols

Successful implementation of proline analog mutagenesis requires robust and validated protocols. The most common method for incorporating analogs into recombinant proteins is Selective Pressure Incorporation (SPI).

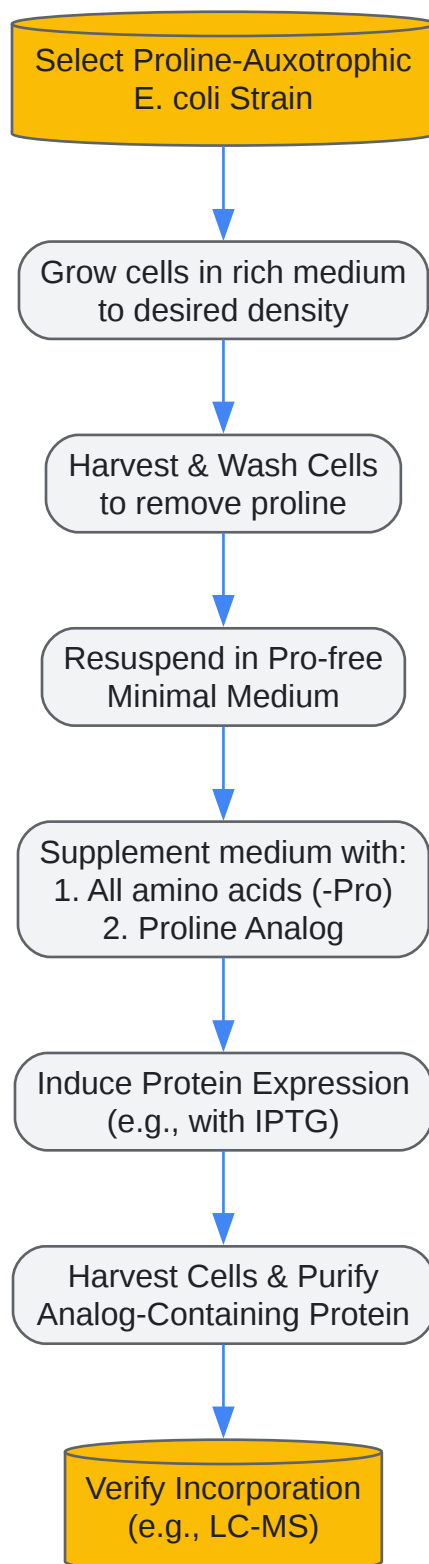

[Click to download full resolution via product page](#)

Caption: Workflow for Selective Pressure Incorporation (SPI) of proline analogs.

Protocol 1: Selective Pressure Incorporation (SPI) of Proline Analogs

This protocol describes the global replacement of all proline residues in a target protein with a desired analog using a proline-auxotrophic E. coli strain.^{[2][6][7]}

Rationale: A proline-auxotrophic strain cannot synthesize its own proline. By providing a medium that lacks proline but contains the desired analog, the cell is forced to incorporate the analog into all newly synthesized proteins to survive.^{[6][7]}

Materials:

- Proline-auxotrophic E. coli expression strain (e.g., BL21(DE3) Δ proC).
- Expression vector containing the gene of interest.
- Rich medium (e.g., LB Broth).
- M9 minimal medium salts.
- Sterile glucose, MgSO₄, CaCl₂.
- Complete amino acid supplement mixture lacking proline.
- Proline analog (e.g., (4R)-fluoroproline).
- Inducing agent (e.g., IPTG).
- Sterile water and centrifuge tubes.

Methodology:

- **Starter Culture:** Inoculate 5-10 mL of rich medium (supplemented with appropriate antibiotic) with a single colony of the transformed auxotrophic strain. Grow overnight at 37°C with shaking.
- **Scale-Up:** Use the starter culture to inoculate a larger volume (e.g., 1 L) of rich medium. Grow at 37°C until the optical density at 600 nm (OD₆₀₀) reaches 0.6-0.8. This step ensures

a healthy and substantial cell mass before switching to the selective medium.

- **Proline Depletion:** Harvest the cells by centrifugation (e.g., 5000 x g for 15 min at 4°C). To remove all traces of proline, gently wash the cell pellet twice with sterile M9 salts solution (without any carbon or nitrogen source), centrifuging between washes.
- **Resuspension and Induction:** Resuspend the final cell pellet in M9 minimal medium supplemented with glucose, MgSO₄, CaCl₂, the complete amino acid mixture (-Pro), and the target proline analog (typically 0.5-1.0 mM). Allow the cells to acclimate for 30-60 minutes at the desired induction temperature (e.g., 18-30°C).
- **Expression:** Induce protein expression by adding IPTG to a final concentration of 0.1-1.0 mM. Continue to incubate for 4-16 hours.
- **Harvest and Verification:** Harvest the cells by centrifugation. Purify the target protein using standard methods (e.g., Ni-NTA affinity chromatography for His-tagged proteins). The successful incorporation and its extent should be verified by intact protein mass analysis using LC-ESI-TOF-MS.[6]

Protocol 2: Analysis of Protein Thermal Stability by Differential Scanning Calorimetry (DSC)

Rationale: DSC directly measures the heat absorbed by a protein solution as it is heated, allowing for the precise determination of the thermal unfolding transition midpoint (T_m). An increase in T_m for an analog-containing variant compared to the wild-type protein indicates stabilization.

Materials:

- Purified wild-type and analog-containing protein samples ($\geq 95\%$ purity).
- Dialysis buffer (e.g., PBS, pH 7.4).
- DSC instrument.

Methodology:

- **Sample Preparation:** Dialyze both wild-type and variant proteins extensively against the same buffer to ensure identical solution conditions. Adjust the protein concentration to 0.5-1.0 mg/mL. The buffer from the final dialysis step should be reserved for use as the reference sample.
- **Instrument Setup:** Equilibrate the DSC instrument at the starting temperature (e.g., 20°C). Load the protein sample into the sample cell and the matched dialysis buffer into the reference cell. Ensure no bubbles are present.
- **Data Acquisition:** Pressurize the cells according to the manufacturer's instructions. Initiate a temperature scan from the starting temperature to a final temperature well above the expected unfolding transition (e.g., 20°C to 95°C) at a constant scan rate (e.g., 60°C/hour).
- **Data Analysis:** After subtracting the buffer-buffer baseline scan, the resulting thermogram will show an endothermic peak corresponding to protein unfolding. Use the instrument's software to fit the data to a two-state unfolding model to determine the T_m , which is the temperature at the peak of the transition. A positive shift in T_m for the variant indicates increased thermal stability.[4]

Conclusion

Proline analogs are sophisticated tools that grant protein engineers unprecedented control over protein backbone conformation, stability, and folding kinetics. By understanding the fundamental principles of ring pucker and amide isomerization, researchers can select the appropriate analog to achieve a desired outcome—be it the thermal stabilization of a therapeutic protein with R-Flp, the acceleration of a slow folding step with thioproline, or the creation of novel biomaterials with hydroxyproline. The experimental protocols provided herein offer a validated pathway to harnessing the power of these unique chemical building blocks, opening new avenues for the rational design of proteins with enhanced and novel functions.

References

- Gutta, S., et al. (2016). Molecular insights into protein synthesis with proline residues. *EMBO reports*, 17(12), 1797–1807. [[Link](#)]
- Kubyshkin, V., et al. (2022). Residue-Specific Exchange of Proline by Proline Analogs in Fluorescent Proteins: How "Molecular Surgery" of the Backbone Affects Folding and Stability.

Journal of Visualized Experiments, (180), e63529. [\[Link\]](#)

- Zondlo, N. J. (2013). Proline Editing: A General and Practical Approach to the Synthesis of Functionally and Structurally Diverse Peptides. Analysis of Steric versus Stereoelectronic Effects of 4-Substituted Prolines on Conformation within Peptides. *Journal of the American Chemical Society*, 135(41), 15479–15492. [\[Link\]](#)
- Breunig, M. M., & Tirrell, D. A. (2021). Incorporation of proline analogs into recombinant proteins expressed in *Escherichia coli*. *Methods in Enzymology*, 655, 185–204. [\[Link\]](#)
- Kubyshkin, V., & Budisa, N. (2017). Molecular Mechanisms and Experimental Strategies for Understanding Plant Drought Response. MDPI. [\[Link\]](#)
- Zondlo, N. J. (2013). Analysis of Steric versus Stereoelectronic Effects of 4-Substituted Prolines on Conformation within Peptides. *Journal of the American Chemical Society*. [\[Link\]](#)
- Kubyshkin, V., et al. (2022). Residue-Specific Exchange of Proline by Proline Analogs in Fluorescent Proteins: How "Molecular Surgery" of the Backbone Affects Folding and Stability. ResearchGate. [\[Link\]](#)
- Tran, T. T., et al. (2013). Properties, metabolisms, and applications of L-proline analogues. *Applied Microbiology and Biotechnology*, 97(19), 8465–8475. [\[Link\]](#)
- Matthews, C. R. (1993). Thermodynamic effects of proline introduction on protein stability. ResearchGate. [\[Link\]](#)
- Kubyshkin, V., & Rubini, M. (2024). Proline Analogues. *Chemical Reviews*, 124(13), 8130–8232. [\[Link\]](#)
- Kubyshkin, V., et al. (2024). Proline Analogues in Drug Design: Current Trends and Future Prospects. *Journal of Medicinal Chemistry*. [\[Link\]](#)
- Chen, J., et al. (2021). Metabolic engineering strategy for synthesizing trans-4-hydroxy-L-proline in microorganisms. *Synthetic and Systems Biotechnology*, 6(2), 77–86. [\[Link\]](#)
- Rubini, M., et al. (2024). 4-Thiaproline accelerates the slow folding phase of proteins containing cis prolines in the native state by two orders of magnitude. *Protein Science*, 33(1),

e4863. [\[Link\]](#)

- Renner, C., et al. (2001). Fluoroprolines as Tools for Protein Design and Engineering. *Angewandte Chemie International Edition*, 40(5), 923-925. [\[Link\]](#)
- Kang, Y. K. (2006). Impact of cis-proline analogs on peptide conformation. *Journal of computational chemistry*, 27(5), 585–596. [\[Link\]](#)
- Osorio-Martinez, C., et al. (2010). Conformational Preferences of α -Substituted Proline Analogues. *The Journal of Organic Chemistry*, 75(15), 5121–5131. [\[Link\]](#)
- Rubini, M., et al. (2024). Fluoroprolines as Tools for Protein Design and Engineering. *ResearchGate*. [\[Link\]](#)
- López, J. C., et al. (2021). Decoding the Structure of Non-Proteinogenic Amino Acids: The Rotational Spectrum of Jet-Cooled Laser-Ablated Thioproline. *Molecules*, 26(24), 7586. [\[Link\]](#)
- de Haan, J. J., et al. (2019). Identification of 4-Hydroxyproline at the Xaa Position in Collagen by Mass Spectrometry. *Journal of Proteome Research*, 18(5), 2311–2318. [\[Link\]](#)
- Wang, Y., et al. (2023). Preparation and Characterization of Hydroxylated Recombinant Collagen by Incorporating Proline and Hydroxyproline in Proline-Deficient *Escherichia coli*. *International Journal of Molecular Sciences*, 24(13), 11090. [\[Link\]](#)
- Wan, X.-C., et al. (2024). Thioproline-Based Oxidation Strategy for Direct Preparation of N-Terminal Thiazolidine-Containing Peptide Thioesters from Peptide Hydrazides. *Organic Letters*. [\[Link\]](#)
- Verhoorck, S. J., Killoran, P. M., & Coxon, C. R. (2018). Fluorinated Prolines as Conformational Tools and Reporters for Peptide and Protein Chemistry. *Biochemistry*, 57(42), 6039–6051. [\[Link\]](#)
- Sneh, M., & Urimi, G. (2021). Influence of Hydroxyproline on Mechanical Behavior of Collagen Mimetic Proteins Under Fraying Deformation—Molecular Dynamics Investigations. *Journal of Biomechanical Engineering*, 143(12), 121005. [\[Link\]](#)

- Tran, T. T., et al. (2013). Properties, metabolisms, and applications of (L)-proline analogues. *Applied Microbiology and Biotechnology*, 97(19), 8465-75. [[Link](#)]
- López, J. C., et al. (2021). The thioproline (SPro) molecule. ResearchGate. [[Link](#)]
- Lescrinier, E., et al. (2022). Fluorine NMR study of proline-rich sequences using fluoroprolines. *Journal of Magnetic Resonance Open*, 12-13, 100072. [[Link](#)]
- Long, M., et al. (2020). Significantly enhancing production of trans-4-hydroxy-l-proline by integrated system engineering in *Escherichia coli*. *Science Advances*, 6(21), eaba2383. [[Link](#)]
- Downes, S. (2019). Thioproline in proteins. Wiley Analytical Science. [[Link](#)]
- Shoulders, M. D., & Raines, R. T. (2011). 4-Fluoroprolines: Conformational Analysis and Effects on the Stability and Folding of Peptides and Proteins. *Israel Journal of Chemistry*, 51(8-9), 918-926. [[Link](#)]
- Kubyshkin, V., et al. (2024). Proline Analogues in Drug Design: Current Trends and Future Prospects. ResearchGate. [[Link](#)]

Need Custom Synthesis?

BenchChem offers custom synthesis for rare earth carbides and specific isotopic labeling.

Email: info@benchchem.com or [Request Quote Online](#).

Sources

- [1. Molecular insights into protein synthesis with proline residues - PMC](#) [[pmc.ncbi.nlm.nih.gov](https://pubmed.ncbi.nlm.nih.gov/)]
- [2. Incorporation of proline analogs into recombinant proteins expressed in Escherichia coli - PMC](#) [[pmc.ncbi.nlm.nih.gov](https://pubmed.ncbi.nlm.nih.gov/)]
- [3. merckmillipore.com](#) [[merckmillipore.com](https://www.merckmillipore.com/)]
- [4. researchgate.net](#) [[researchgate.net](https://www.researchgate.net/)]
- [5. pubs.acs.org](#) [pubs.acs.org]

- 6. Residue-Specific Exchange of Proline by Proline Analogs in Fluorescent Proteins: How "Molecular Surgery" of the Backbone Affects Folding and Stability [jove.com]
- 7. researchgate.net [researchgate.net]
- 8. researchgate.net [researchgate.net]
- 9. pubs.acs.org [pubs.acs.org]
- 10. Proline Analogues in Drug Design: Current Trends and Future Prospects - PubMed [pubmed.ncbi.nlm.nih.gov]
- 11. 4-Thiaproline accelerates the slow folding phase of proteins containing cis prolines in the native state by two orders of magnitude - PMC [pmc.ncbi.nlm.nih.gov]
- 12. researchgate.net [researchgate.net]
- 13. pubs.acs.org [pubs.acs.org]
- 14. raineslab.com [raineslab.com]
- 15. Fluoroprolines as Tools for Protein Design and Engineering - PubMed [pubmed.ncbi.nlm.nih.gov]
- 16. mr.copernicus.org [mr.copernicus.org]
- 17. pubs.acs.org [pubs.acs.org]
- 18. asmedigitalcollection.asme.org [asmedigitalcollection.asme.org]
- 19. Properties, metabolisms, and applications of (L)-proline analogues - PubMed [pubmed.ncbi.nlm.nih.gov]
- 20. Metabolic engineering strategy for synthesizing trans-4-hydroxy-L-proline in microorganisms - PMC [pmc.ncbi.nlm.nih.gov]
- 21. mdpi.com [mdpi.com]
- 22. analyticalscience.wiley.com [analyticalscience.wiley.com]
- 23. Impact of cis-proline analogs on peptide conformation - PubMed [pubmed.ncbi.nlm.nih.gov]
- 24. Conformational Preferences of α -Substituted Proline Analogues - PMC [pmc.ncbi.nlm.nih.gov]
- To cite this document: BenchChem. [A Senior Application Scientist's Guide to Proline Analogs in Protein Engineering]. BenchChem, [2026]. [Online PDF]. Available at: [https://www.benchchem.com/product/b555074/docs#a-senior-application-scientist-s-guide-to-proline-analogs-in-protein-engineering]

Disclaimer & Data Validity:

The information provided in this document is for Research Use Only (RUO) and is strictly not intended for diagnostic or therapeutic procedures. While BenchChem strives to provide accurate protocols, we make no warranties, express or implied, regarding the fitness of this product for every specific experimental setup.

Technical Support: The protocols provided are for reference purposes. Unsure if this reagent suits your experiment?

Need Industrial/Bulk Grade? [Request Custom Synthesis Quote](#)

BenchChem

Our mission is to be the trusted global source of essential and advanced chemicals, empowering scientists and researchers to drive progress in science and industry.

Contact

Address: 3281 E Guasti Rd
Ontario, CA 91761, United States
Phone: (601) 213-4426
Email: info@benchchem.com

[Contact our Ph.D. Support Team for a compatibility check](#)