

A Researcher's Guide to Alternative Substrates for Measuring Cathepsin B Activity

Author: BenchChem Technical Support Team. **Date:** May 2026

Compound of Interest

Compound Name: Z-Arg-Amc HCl

CAS No.: 70375-22-3

Cat. No.: B554434

[Get Quote](#)

In the intricate world of cellular biology and drug development, the precise measurement of enzyme activity is paramount. Cathepsin B, a lysosomal cysteine protease, plays a pivotal role in various physiological and pathological processes, including protein turnover, apoptosis, and cancer progression. Consequently, the accurate quantification of its activity is crucial for advancing our understanding of these processes and for the development of targeted therapeutics. While traditional substrates have been widely used, the quest for improved specificity, sensitivity, and versatility has led to the development of a range of alternative substrates. This guide provides an in-depth comparison of these alternatives, supported by experimental data, to empower researchers in selecting the optimal tool for their specific needs.

The Limitations of Conventional Cathepsin B Substrates

Historically, substrates such as Z-Arg-Arg-AMC and Z-Phe-Arg-AMC have been the workhorses for measuring cathepsin B activity. However, their utility is often compromised by a lack of specificity, as they can be cleaved by other cysteine cathepsins like cathepsins L, K, S, and V.^{[1][2]} This cross-reactivity can lead to ambiguous results, particularly in complex biological samples where multiple cathepsins are present. Furthermore, the activity of some

traditional substrates, such as Z-Arg-Arg-AMC, is significantly diminished at the acidic pH characteristic of the lysosome, the primary location of active cathepsin B.[1][3] These limitations underscore the critical need for alternative substrates that offer enhanced specificity and robust performance across a range of pH conditions.

A New Generation of Fluorogenic Substrates: Enhanced Specificity and Performance

Recent advancements in peptide chemistry have led to the design of novel fluorogenic substrates with superior specificity for cathepsin B. Among these, Z-Nle-Lys-Arg-AMC has emerged as a particularly promising alternative.

Z-Nle-Lys-Arg-AMC: A Highly Specific and Versatile Substrate

Extensive studies have demonstrated that Z-Nle-Lys-Arg-AMC is specifically cleaved by cathepsin B and not by other closely related cysteine cathepsins, including L, K, S, V, and X.[1][2] This high degree of specificity is a significant advantage over its predecessors. Moreover, Z-Nle-Lys-Arg-AMC exhibits robust activity over a broad pH range, making it suitable for measuring cathepsin B activity in both the acidic environment of the lysosome and the neutral pH of the cytosol.[1][2]

The superior performance of Z-Nle-Lys-Arg-AMC is further evidenced by its kinetic parameters. As shown in the table below, this substrate demonstrates high catalytic efficiency (k_{cat}/K_m) for cathepsin B at both acidic and neutral pH, outperforming the commonly used Z-Arg-Arg-AMC.[1][2]

Table 1: Comparative Kinetic Parameters of Fluorogenic Cathepsin B Substrates

Substrate	pH	Km (μM)	kcat (s^{-1})	kcat/Km ($\text{M}^{-1}\text{s}^{-1}$)
Z-Nle-Lys-Arg-AMC	4.6	130 \pm 19	1.9 \pm 0.08	15,000 \pm 2,500
7.2	110 \pm 17	11 \pm 0.5	96,000 \pm 16,000	
Z-Arg-Arg-AMC	4.6	210 \pm 30	0.2 \pm 0.01	1,000 \pm 200
7.2	150 \pm 25	3.5 \pm 0.2	23,000 \pm 4,000	
Z-Phe-Arg-AMC	4.6	90 \pm 15	2.5 \pm 0.1	28,000 \pm 5,000
7.2	120 \pm 20	10 \pm 0.6	83,000 \pm 14,000	

Data adapted
from Yoon et al.
(2023).[1][2]

The underlying principle of this assay involves the enzymatic cleavage of the AMC (7-amino-4-methylcoumarin) group from the peptide backbone, resulting in a quantifiable fluorescent signal.

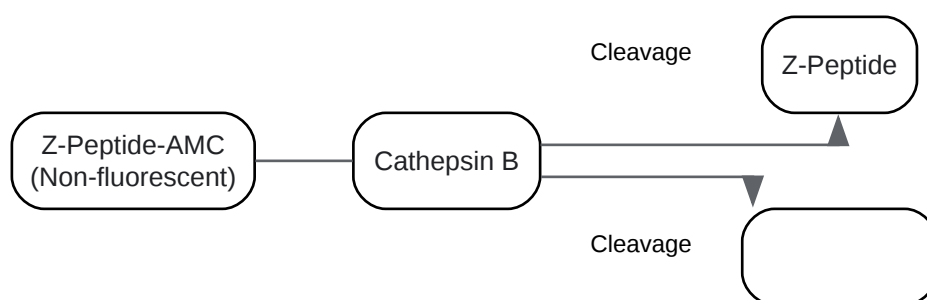

[Click to download full resolution via product page](#)

Caption: Cathepsin B cleaves the non-fluorescent substrate, releasing a fluorescent reporter.

Beyond AMC: Exploring Other Detection Modalities

While AMC-based substrates are widely used, other detection methods offer unique advantages for specific applications.

Colorimetric Substrates

For laboratories not equipped with fluorescence plate readers, colorimetric substrates provide a viable alternative. Z-Arg-Arg-pNA (p-nitroanilide) is a chromogenic substrate that, upon cleavage by cathepsin B, releases p-nitroaniline, a yellow product that can be quantified using a standard spectrophotometer.[4][5]

FRET-Based Substrates

Förster Resonance Energy Transfer (FRET) substrates employ a donor-quencher pair linked by a cathepsin B-cleavable peptide. In the intact substrate, the fluorescence of the donor is quenched. Upon cleavage, the donor and quencher are separated, leading to an increase in fluorescence. This technology allows for the design of highly sensitive and specific assays and can be adapted for simultaneous detection of multiple cathepsins using spectrally distinct fluorophores.[1][5]

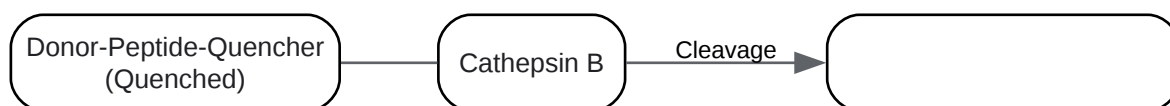

[Click to download full resolution via product page](#)

Caption: FRET substrate cleavage by Cathepsin B separates the donor and quencher, restoring fluorescence.

Activity-Based Probes (ABPs)

Activity-based probes represent a distinct class of reagents that covalently bind to the active site of cathepsin B in an activity-dependent manner.[6][7] These probes typically consist of a reactive "warhead" that forms a covalent bond with the catalytic cysteine residue, a peptide recognition sequence that confers specificity, and a reporter tag (e.g., a fluorophore or biotin) for detection.[8] Quenched ABPs (qABPs) are a sophisticated variation where the fluorescent signal is initially quenched and only becomes unmasked upon covalent binding to the active enzyme, thereby minimizing background fluorescence.[9] ABPs are particularly valuable for in situ imaging of cathepsin B activity within living cells and tissues.[6]

Experimental Protocol: Measuring Cathepsin B Activity with a Fluorogenic Substrate

This protocol provides a general framework for measuring cathepsin B activity using a fluorogenic peptide-AMC substrate. It is essential to optimize buffer conditions, enzyme concentration, and substrate concentration for each specific experimental setup.

Materials:

- Purified active cathepsin B or cell/tissue lysate
- Fluorogenic cathepsin B substrate (e.g., Z-Nle-Lys-Arg-AMC)
- Assay Buffer: 50 mM sodium acetate, 2 mM EDTA, 5 mM DTT, pH 5.5 (adjust pH as needed for your experiment)
- 96-well black, flat-bottom microplate
- Fluorescence microplate reader (Excitation ~360 nm, Emission ~460 nm)

Procedure:

- Prepare Reagents:
 - Reconstitute the fluorogenic substrate in DMSO to create a stock solution (e.g., 10 mM).
 - Prepare working solutions of the substrate by diluting the stock in Assay Buffer to the desired final concentrations.
 - Prepare a solution of cathepsin B in Assay Buffer. The optimal concentration should be determined empirically through a titration experiment.
- Assay Setup:
 - Pipette 50 μ L of Assay Buffer into each well of the microplate.
 - Add 25 μ L of the cathepsin B solution to the appropriate wells.

- For negative control wells, add 25 μL of Assay Buffer instead of the enzyme solution.
- Include a substrate blank containing only Assay Buffer and the substrate.
- Initiate the Reaction:
 - Add 25 μL of the substrate working solution to all wells to initiate the reaction. The final volume in each well will be 100 μL .
- Incubation and Measurement:
 - Immediately place the plate in the fluorescence microplate reader.
 - Measure the fluorescence intensity kinetically at 37°C for a set period (e.g., 30-60 minutes), taking readings every 1-2 minutes.
- Data Analysis:
 - Determine the rate of reaction (V_0) from the linear portion of the fluorescence versus time plot.
 - Subtract the rate of the negative control (no enzyme) from the rates of the experimental samples.
 - If absolute quantification is required, generate a standard curve using free AMC.

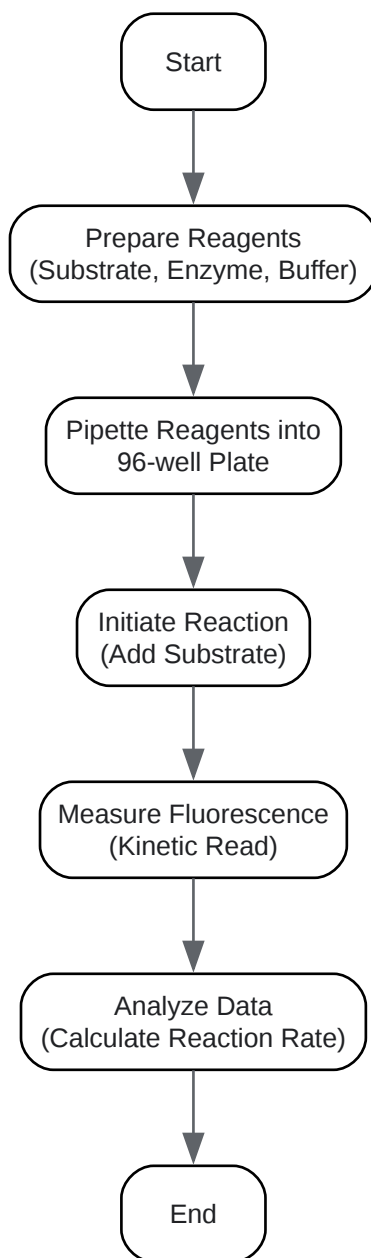

[Click to download full resolution via product page](#)

Caption: Workflow for a typical Cathepsin B fluorogenic assay.

Conclusion

The landscape of tools available for measuring cathepsin B activity has evolved significantly, offering researchers a diverse array of options with improved specificity and performance. The choice of substrate will ultimately depend on the specific research question, the nature of the biological sample, and the available instrumentation. For applications demanding high

specificity and reliable quantification across different pH environments, Z-Nle-Lys-Arg-AMC stands out as a superior choice. For in situ visualization of enzymatic activity, activity-based probes provide an unparalleled advantage. By carefully considering the strengths and limitations of each alternative, researchers can confidently select the most appropriate substrate to advance their investigations into the multifaceted roles of cathepsin B.

References

- Yoon, M. C., et al. (2023). Distinct Cleavage Properties of Cathepsin B Compared to Cysteine Cathepsins Enable the Design and Validation of a Specific Substrate for Cathepsin B over a Broad pH Range. *Biochemistry*, 62(15), 2289–2300. [[Link](#)]
- Hook, V., et al. (2023). Distinct Cleavage Properties of Cathepsin B Compared to Cysteine Cathepsins Enable the Design and Validation of a Specific Substrate for Cathepsin B over a Broad pH Range. eScholarship, University of California. [[Link](#)]
- Poreba, M., et al. (2019). Fluorescent probes towards selective cathepsin B detection and visualization in cancer cells and patient samples. *Chemical Science*, 10(33), 7853–7865. [[Link](#)]
- Bogoyo, M., et al. (2000). Substrate Specificity and Affinity of Cysteine Proteases as Determined by a Novel Fluorescence Quenched Activity-Based Probe. *Chemistry & Biology*, 7(1), 27-38.
- Watzke, A., et al. (2007). A new assay using fluorogenic substrates and immunofluorescence staining to measure cysteine cathepsin activity in live cell subpopulations. *Cytometry Part A*, 71A(3), 197-206. [[Link](#)]
- Schmitz, J., et al. (2018). Cathepsin B: Active Site Mapping with Peptidic Substrates and Inhibitors. *Molecules*, 23(12), 3193. [[Link](#)]
- Kasperkiewicz, P., et al. (2021). Activity-Based Probes to Utilize the Proteolytic Activity of Cathepsin G in Biological Samples. *Frontiers in Chemistry*, 9, 638334. [[Link](#)]
- BPS Bioscience. (n.d.). Cathepsin B Inhibitor Screening Assay Kit. Retrieved from [[Link](#)]

- Blum, G., et al. (2005). A cathepsin targeted quenched activity-based probe facilitates enhanced detection of human tumors during resection. PLoS ONE, 2(6), e549. [\[Link\]](#)
- Withana, N. P., et al. (2019). Challenges in Bench-to-Bed Translation Involving Inflammation-Targeting Compounds in Chronic Epilepsy: The Case of Cathepsin Activity-Based Probes. ACS Omega, 4(26), 21875–21886. [\[Link\]](#)
- AnaSpec. (n.d.). The Optimization of FRET Substrates for Detection of Cathepsins Activity. Retrieved from [\[Link\]](#)
- Yoon, M. C., et al. (2021). Selective Neutral pH Inhibitor of Cathepsin B Designed Based on Cleavage Preferences at Cytosolic and Lysosomal pH Conditions. Journal of Medicinal Chemistry, 64(22), 16766–16780.
- Lee, S., et al. (2022). FRET-Based Cathepsin Probes for Simultaneous Detection of Cathepsin B and D Activities. ChemBioChem, 23(19), e202200319. [\[Link\]](#)
- BPS Bioscience. (n.d.). Fluorogenic Cathepsin F Substrate. Retrieved from [\[Link\]](#)
- Lesner, A., et al. (2004). Fluorogenic peptide substrates for carboxydipeptidase activity of cathepsin B. Biological Chemistry, 385(6), 505-509.
- Ren, G., et al. (2023). Radioactive and Fluorescent Dual Modality Cysteine Cathepsin B Activity-Based Probe for Cancer Theranostics. Molecular Pharmaceutics, 20(7), 3647–3657. [\[Link\]](#)
- Blum, G., et al. (2009). Comparative Assessment of Substrates and Activity Based Probes as Tools for Non-Invasive Optical Imaging of Cysteine Protease Activity. PLoS ONE, 4(7), e6374. [\[Link\]](#)
- Hook, G., et al. (2021). Cathepsin B Dipeptidyl Carboxypeptidase and Endopeptidase Activities Demonstrated across a Broad pH Range. Biomolecules, 11(7), 999. [\[Link\]](#)
- Sexton, K. B., et al. (2007). Direct Measurement of Cathepsin B Activity in the Cytosol of Apoptotic Cells by an Activity-Based Probe. Biochemistry, 46(31), 8979–8984. [\[Link\]](#)

Need Custom Synthesis?

BenchChem offers custom synthesis for rare earth carbides and specific isotopic labeling.

Email: info@benchchem.com or [Request Quote Online](#).

Sources

- 1. Distinct Cleavage Properties of Cathepsin B Compared to Cysteine Cathepsins Enable the Design and Validation of a Specific Substrate for Cathepsin B over a Broad pH Range - PMC [[pmc.ncbi.nlm.nih.gov](https://pubmed.ncbi.nlm.nih.gov/)]
- 2. pubs.acs.org [pubs.acs.org]
- 3. researchgate.net [researchgate.net]
- 4. FRET-Based Cathepsin Probes for Simultaneous Detection of Cathepsin B and D Activities - PubMed [pubmed.ncbi.nlm.nih.gov]
- 5. Radioactive and Fluorescent Dual Modality Cysteine Cathepsin B Activity-Based Probe for Cancer Theranostics - PMC [[pmc.ncbi.nlm.nih.gov](https://pubmed.ncbi.nlm.nih.gov/)]
- 6. Fluorescent probes towards selective cathepsin B detection and visualization in cancer cells and patient samples - Chemical Science (RSC Publishing) [pubs.rsc.org]
- 7. researchgate.net [researchgate.net]
- 8. researchgate.net [researchgate.net]
- 9. medchemexpress.com [medchemexpress.com]
- To cite this document: BenchChem. [A Researcher's Guide to Alternative Substrates for Measuring Cathepsin B Activity]. BenchChem, [2026]. [Online PDF]. Available at: [<https://www.benchchem.com/product/b554434/docs#a-researcher-s-guide-to-alternative-substrates-for-measuring-cathepsin-b-activity>]

Disclaimer & Data Validity:

The information provided in this document is for Research Use Only (RUO) and is strictly not intended for diagnostic or therapeutic procedures. While BenchChem strives to provide accurate protocols, we make no warranties, express or implied, regarding the fitness of this product for every specific experimental setup.

Technical Support: The protocols provided are for reference purposes. Unsure if this reagent suits your experiment?

Need Industrial/Bulk Grade? [Request Custom Synthesis Quote](#)

BenchChem

Our mission is to be the trusted global source of essential and advanced chemicals, empowering scientists and researchers to drive progress in science and industry.

Contact

Address: 3281 E Guasti Rd
Ontario, CA 91761, United States
Phone: (601) 213-4426
Email: info@benchchem.com

[Contact our Ph.D. Support Team for a compatibility check](#)