

Technical Support Center: MAGE-3 (271-279) T-Cell Stimulation

Author: BenchChem Technical Support Team. **Date:** April 2026

Compound of Interest

Compound Name: MAGE-3 (271-279)

CAS No.: 160295-81-8

Cat. No.: B550807

[Get Quote](#)

Welcome to the technical support center for researchers working with the **MAGE-3 (271-279)** peptide. This guide provides troubleshooting advice and frequently asked questions to address common issues encountered during in vitro T-cell stimulation experiments.

Frequently Asked Questions (FAQs)

Q1: What is the **MAGE-3 (271-279)** peptide and why is it used?

A1: The **MAGE-3 (271-279)** peptide, with the amino acid sequence FLWGPRALV, is a well-characterized epitope derived from the Melanoma-associated antigen 3 (MAGE-A3) protein.[1][2][3] It is presented by the human leukocyte antigen (HLA)-A2 molecule and is a target for cytotoxic T lymphocytes (CTLs).[2][3] MAGE-A3 is a cancer-testis antigen, meaning it is expressed in various tumor types but not in most normal adult tissues, making it an attractive target for cancer immunotherapy research.[2][4]

Q2: I am not seeing any T-cell response after stimulating PBMCs with the **MAGE-3 (271-279)** peptide. What are the possible reasons?

A2: A low or absent T-cell response can stem from several factors:

- **Low Precursor Frequency:** The frequency of T-cells specific for a single peptide like **MAGE-3 (271-279)** in a given individual can be very low.[\[5\]](#)[\[6\]](#)
- **T-Cell Exhaustion:** T-cells, particularly from cancer patients, may be in a state of exhaustion, characterized by the expression of inhibitory receptors like PD-1, TIM-3, and LAG-3, leading to reduced proliferative capacity and cytokine production.[\[7\]](#)[\[8\]](#)[\[9\]](#)
- **Incorrect HLA Haplotype:** The **MAGE-3 (271-279)** peptide is primarily presented by HLA-A2. Ensure your T-cell donors are HLA-A2 positive.
- **Suboptimal Experimental Conditions:** Issues with peptide quality, cell viability, or assay protocol can all lead to a failed experiment. Please refer to the troubleshooting section for more details.
- **Antigen Processing and Presentation:** Some tumor cells may not efficiently process and present the **MAGE-3 (271-279)** epitope, even if they express the MAGE-A3 protein.[\[10\]](#)[\[11\]](#)

Q3: What are the expected readouts for a successful **MAGE-3 (271-279)** stimulation experiment?

A3: A successful T-cell response can be measured by:

- **Cytokine Production:** Primarily interferon-gamma (IFN- γ), which can be detected by ELISpot or intracellular cytokine staining (ICS) followed by flow cytometry.[\[12\]](#)
- **T-Cell Proliferation:** An increase in the number of MAGE-3 specific T-cells, often measured using CFSE dilution assays.[\[13\]](#)
- **Cytotoxicity:** The ability of stimulated T-cells to kill target cells pulsed with the **MAGE-3 (271-279)** peptide, commonly assessed by chromium-51 release assays.[\[1\]](#)[\[5\]](#)
- **Upregulation of Activation Markers:** Increased expression of markers like CD69 and CD137 on T-cells following stimulation.[\[14\]](#)

Q4: Is it necessary to use adjuvants or other co-stimulatory molecules in the in vitro culture?

A4: While not always strictly necessary for short-term stimulation assays, the addition of cytokines like IL-2 and IL-7 can help support the proliferation and survival of activated T-cells, especially in longer-term cultures for generating CTL lines.[12] Some studies have also shown that the use of adjuvants in vaccination settings can enhance the T-cell response to MAGE-3.
[4]

Troubleshooting Guide

This guide addresses specific issues you may encounter during your experiments.

| Problem | Potential Cause | Recommended Solution |
|---|---|---|
| High background in ELISpot assay | <ol style="list-style-type: none"> 1. Contaminated cell culture medium or serum.[15] 2. Cells were previously activated.[15] 3. Too many cells per well.[16] 4. Inadequate washing steps.[16] | <ol style="list-style-type: none"> 1. Use fresh, high-quality reagents. Consider using fetal bovine serum (FBS) instead of human serum.[15] 2. Wash cells thoroughly before plating.[15] 3. Optimize cell density. A typical range is 0.25 to 1.0 million splenocytes per well.[17] 4. Follow the washing protocol carefully.[16] |
| No or faint spots in positive control (e.g., PHA stimulation) | <ol style="list-style-type: none"> 1. Reduced cell viability.[16] 2. Problem with assay reagents (e.g., antibodies, substrate). | <ol style="list-style-type: none"> 1. Check cell viability before starting the experiment. 2. Ensure proper handling of cryopreserved cells.[16] 3. Verify the quality and expiration dates of all reagents. |
| Low frequency of responding T-cells | <ol style="list-style-type: none"> 1. Low precursor frequency in the donor.[5] 2. T-cell anergy or exhaustion.[7][8] 3. Suboptimal peptide concentration. | <ol style="list-style-type: none"> 1. Screen multiple donors. Consider using T-cells from vaccinated individuals if possible.[4] 2. Include co-stimulatory antibodies (e.g., anti-CD28) in your culture. For exhausted T-cells, consider checkpoint inhibitors (e.g., anti-PD-1) in your experimental setup. 3. Perform a dose-response curve to determine the optimal peptide concentration (typically 1-10 µg/ml).[18] |
| Inconsistent replicates | <ol style="list-style-type: none"> 1. Inaccurate pipetting.[16] 2. Cell clumping.[16] 3. Uneven cell distribution in wells.[15] | <ol style="list-style-type: none"> 1. Ensure pipettes are calibrated and use proper pipetting techniques.[16] 2. |

Gently but thoroughly resuspend cells before plating. [16] 3. Add stimuli to the well before adding the cell suspension to ensure even distribution.[15]

Quantitative Data Summary

| Parameter | Typical Range | Reference |
|--|--|----------------------|
| MAGE-3 (271-279) Peptide Concentration | 1 - 10 µg/ml | [18] |
| IL-2 Concentration | 20 units/ml | [12] |
| IL-7 Concentration | 5 ng/ml | [12] |
| T-cell to APC Ratio | 10:1 to 1:1 | Varies by experiment |
| Incubation Time for Stimulation | 16 - 24 hours (ELISpot) 6 hours (ICS) 7-10 days (CTL generation) | Varies by assay |

Experimental Protocols

Protocol 1: In Vitro Stimulation of PBMCs for IFN-γ ELISpot Assay

- Cell Preparation: Isolate Peripheral Blood Mononuclear Cells (PBMCs) from HLA-A2 positive donors. Ensure high viability (>95%).
- Plate Coating: Coat a 96-well PVDF plate with an anti-human IFN-γ capture antibody overnight at 4°C.
- Washing: Wash the plate multiple times with sterile PBS to remove excess antibody.
- Blocking: Block the plate with sterile culture medium containing 10% FBS for at least 30 minutes at room temperature.

- Cell Plating: Add 2×10^5 PBMCs per well.
- Stimulation: Add **MAGE-3 (271-279)** peptide to the appropriate wells at a final concentration of 1-10 $\mu\text{g/ml}$. Include a negative control (medium alone or an irrelevant peptide) and a positive control (e.g., Phytohemagglutinin (PHA)).
- Incubation: Incubate the plate for 16-24 hours at 37°C in a humidified incubator with 5% CO_2 .
- Detection: Lyse the cells and wash the plate. Add a biotinylated anti-human IFN- γ detection antibody.
- Enzyme Conjugation: After washing, add streptavidin-alkaline phosphatase (ALP) or streptavidin-horseradish peroxidase (HRP).
- Development: Add a substrate solution (e.g., BCIP/NBT for ALP or AEC for HRP) and incubate until spots are visible.
- Analysis: Stop the reaction by washing with water. Allow the plate to dry and count the spots using an ELISpot reader.

Protocol 2: Intracellular Cytokine Staining (ICS) for Flow Cytometry

- Cell Preparation: Isolate PBMCs and place them in culture tubes or a 96-well plate at a concentration of $1-2 \times 10^6$ cells/ml.
- Stimulation: Add **MAGE-3 (271-279)** peptide (1-10 $\mu\text{g/ml}$) and a co-stimulatory antibody (e.g., anti-CD28). Include appropriate negative and positive controls.
- Protein Transport Inhibition: Add a protein transport inhibitor (e.g., Brefeldin A or Monensin) for the last 4-6 hours of incubation to allow cytokines to accumulate intracellularly.[\[19\]](#)
- Surface Staining: Wash the cells and stain with fluorochrome-conjugated antibodies against surface markers (e.g., CD3, CD8) to identify the T-cell population of interest.

- Fixation and Permeabilization: Wash the cells and then fix and permeabilize them using a commercial kit.[20]
- Intracellular Staining: Stain the cells with a fluorochrome-conjugated anti-IFN- γ antibody.[20]
- Acquisition: Wash the cells and acquire the data on a flow cytometer.
- Analysis: Analyze the data to determine the percentage of IFN- γ positive cells within the CD8+ T-cell population.

Visualizations

Simplified T-Cell Receptor Signaling Pathway

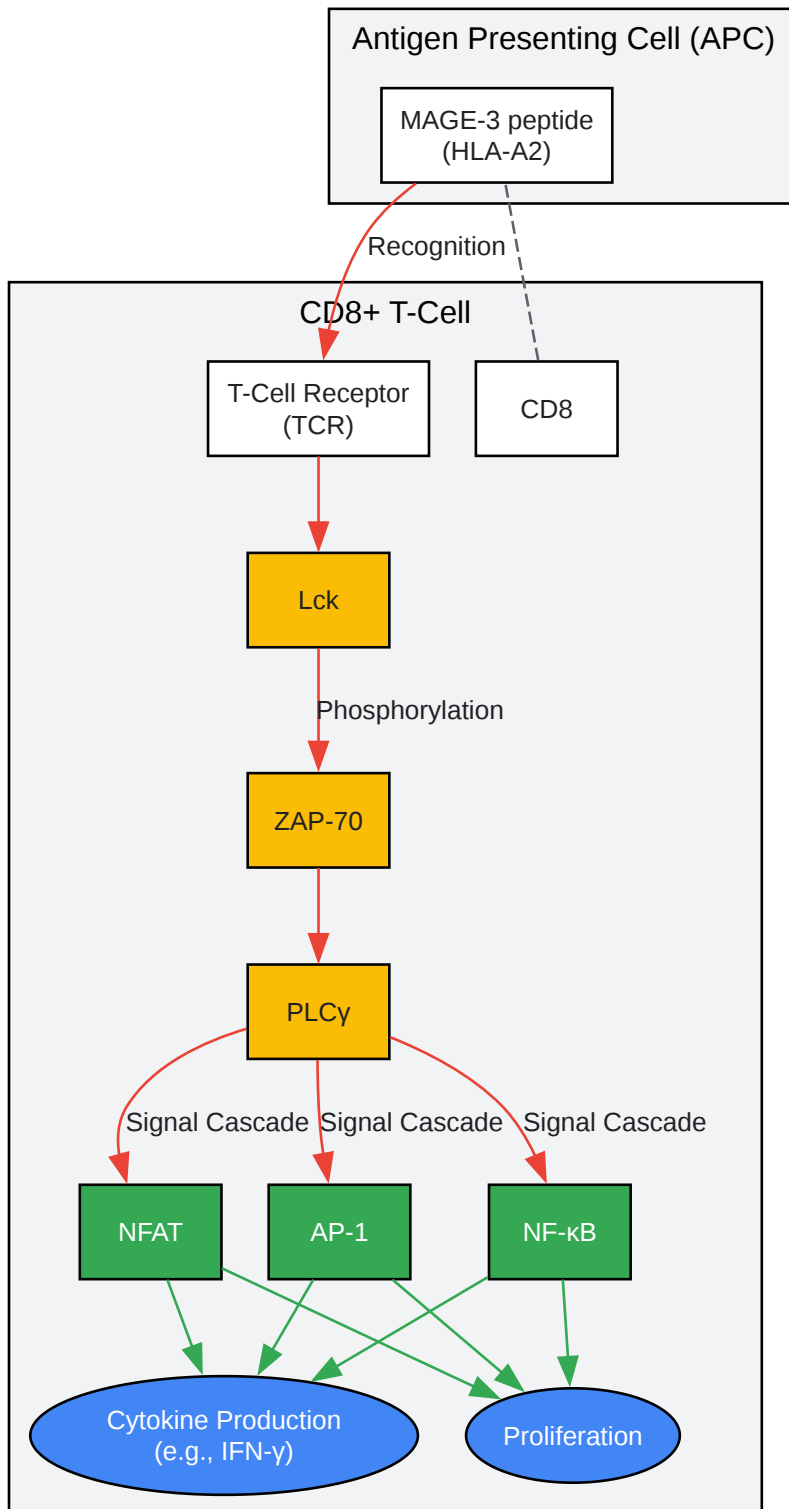

[Click to download full resolution via product page](#)

Caption: Simplified T-Cell Receptor Signaling Pathway.

ELISpot Experimental Workflow

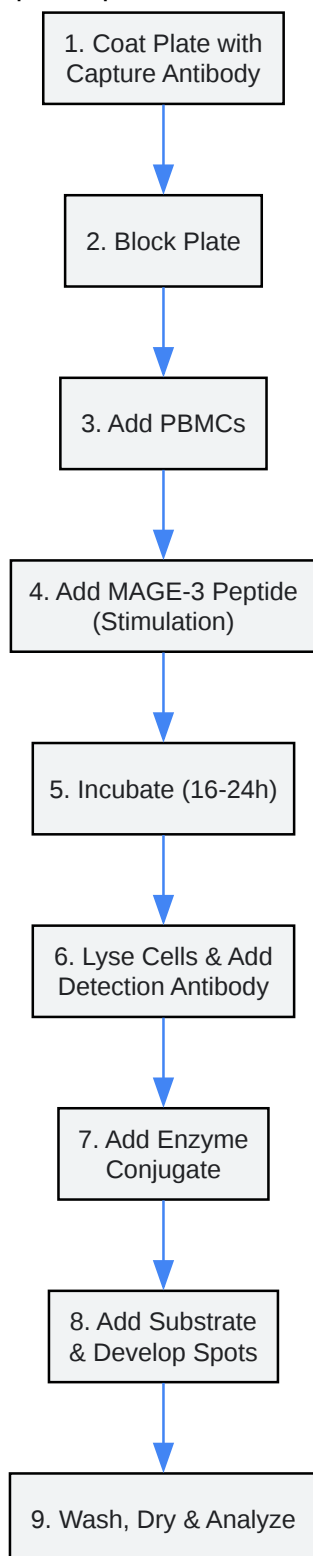

[Click to download full resolution via product page](#)

Caption: ELISpot Experimental Workflow.

Need Custom Synthesis?

BenchChem offers custom synthesis for rare earth carbides and specific isotopic labeling.

Email: info@benchchem.com or [Request Quote Online](#).

References

- 1. Modulation of Proteasomal Activity Required for the Generation of a Cytotoxic T Lymphocyte–defined Peptide Derived from the Tumor Antigen MAGE-3 - PMC [[pmc.ncbi.nlm.nih.gov](https://pubmed.ncbi.nlm.nih.gov/)]
- 2. [medchemexpress.com](https://www.medchemexpress.com/) [[medchemexpress.com](https://www.medchemexpress.com/)]
- 3. A peptide encoded by human gene MAGE-3 and presented by HLA-A2 induces cytolytic T lymphocytes that recognize tumor cells expressing MAGE-3. — MRC Weatherall Institute of Molecular Medicine [[imm.ox.ac.uk](https://www.imm.ox.ac.uk/)]
- 4. Vaccine-induced CD4+ T cell responses to MAGE-3 protein in lung cancer patients. [[vivo.weill.cornell.edu](https://www.vivo.weill.cornell.edu/)]
- 5. Correlation between tumor regression and T cell responses in melanoma patients vaccinated with a MAGE antigen - PMC [[pmc.ncbi.nlm.nih.gov](https://pubmed.ncbi.nlm.nih.gov/)]
- 6. [aacrjournals.org](https://www.aacrjournals.org/) [[aacrjournals.org](https://www.aacrjournals.org/)]
- 7. Tumour antigen-induced T cell exhaustion — the archenemy of immune-hot malignancies - PMC [[pmc.ncbi.nlm.nih.gov](https://pubmed.ncbi.nlm.nih.gov/)]
- 8. [Frontiers | T Cell Dysfunction and Exhaustion in Cancer](https://www.frontiersin.org/) [[frontiersin.org](https://www.frontiersin.org/)]
- 9. [researchgate.net](https://www.researchgate.net/) [[researchgate.net](https://www.researchgate.net/)]
- 10. [researchgate.net](https://www.researchgate.net/) [[researchgate.net](https://www.researchgate.net/)]
- 11. [rupress.org](https://www.rupress.org/) [[rupress.org](https://www.rupress.org/)]
- 12. Quantitative Expression and Immunogenicity of MAGE-3 and -6 in Upper Aerodigestive Tract Cancer - PMC [[pmc.ncbi.nlm.nih.gov](https://pubmed.ncbi.nlm.nih.gov/)]
- 13. [reactionbiology.com](https://www.reactionbiology.com/) [[reactionbiology.com](https://www.reactionbiology.com/)]
- 14. Global analysis of HLA-A2 restricted MAGE-A3 tumor antigen epitopes and corresponding TCRs in non-small cell lung cancer [[thno.org](https://www.thno.org/)]
- 15. [mabtech.com](https://www.mabtech.com/) [[mabtech.com](https://www.mabtech.com/)]
- 16. Troubleshooting T cell ELISPOT assay | U-CyTech [[ucytech.com](https://www.ucytech.com/)]

- [17. researchgate.net \[researchgate.net\]](#)
- [18. pnas.org \[pnas.org\]](#)
- [19. New Methods for Assessing T-Cell Responses - PMC \[pmc.ncbi.nlm.nih.gov\]](#)
- [20. Optimized Intracellular Staining Reveals Heterogeneous Cytokine Production Ability of Murine and Human Hematopoietic Stem and Progenitor Cells - PMC \[pmc.ncbi.nlm.nih.gov\]](#)
- To cite this document: BenchChem. [Technical Support Center: MAGE-3 (271-279) T-Cell Stimulation]. BenchChem, [2026]. [Online PDF]. Available at: [\[https://www.benchchem.com/product/b550807/docs#technical-support-center-mage-3-271-279-t-cell-stimulation\]](https://www.benchchem.com/product/b550807/docs#technical-support-center-mage-3-271-279-t-cell-stimulation)

Disclaimer & Data Validity:

The information provided in this document is for Research Use Only (RUO) and is strictly not intended for diagnostic or therapeutic procedures. While BenchChem strives to provide accurate protocols, we make no warranties, express or implied, regarding the fitness of this product for every specific experimental setup.

Technical Support: The protocols provided are for reference purposes. Unsure if this reagent suits your experiment?

Need Industrial/Bulk Grade? [Request Custom Synthesis Quote](#)

BenchChem

Our mission is to be the trusted global source of essential and advanced chemicals, empowering scientists and researchers to drive progress in science and industry.

Contact

Address: 3281 E Guasti Rd
Ontario, CA 91761, United States
Phone: (601) 213-4426
Email: info@benchchem.com

Contact our Ph.D. Support Team for a compatibility check