

# A Comparative Analysis of the Post-Antibiotic Effect of Teicoplanin and Linezolid

**Author:** BenchChem Technical Support Team. **Date:** December 2025

## Compound of Interest

Compound Name: *Teicoplanin*

Cat. No.: *B549275*

[Get Quote](#)

In the landscape of antimicrobial research and development, understanding the pharmacodynamic properties of antibiotics is paramount to optimizing dosing regimens and combating bacterial resistance. One crucial parameter is the post-antibiotic effect (PAE), the persistent suppression of bacterial growth after a brief exposure to an antimicrobial agent. This guide provides a detailed comparison of the PAE of two important antibiotics used against Gram-positive infections: **teicoplanin**, a glycopeptide, and linezolid, an oxazolidinone.

This comparison synthesizes available experimental data, outlines the methodologies for PAE determination, and visually represents the mechanisms of action and experimental workflows for researchers, scientists, and drug development professionals.

## Mechanisms of Action: A Tale of Two Targets

The differing PAEs of **teicoplanin** and linezolid are rooted in their distinct mechanisms of action.

**Teicoplanin:** This glycopeptide antibiotic inhibits the synthesis of the bacterial cell wall.<sup>[1][2][3]</sup> It achieves this by binding to the D-alanyl-D-alanine termini of peptidoglycan precursors, thereby blocking the transglycosylation and transpeptidation steps essential for cell wall polymerization.<sup>[1]</sup> This disruption of the cell wall integrity ultimately leads to bacterial cell death.

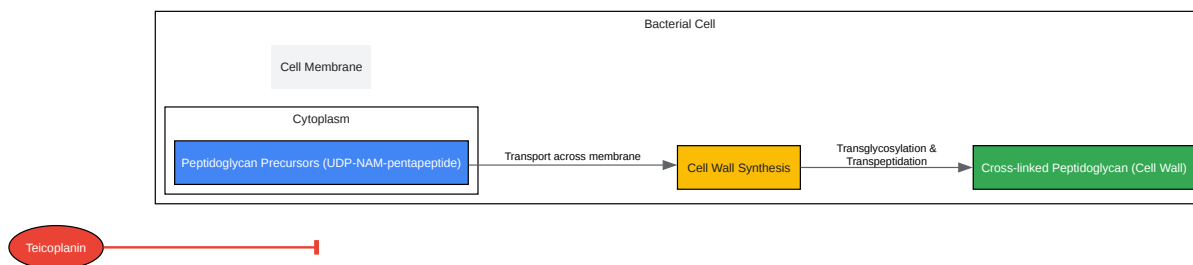

[Click to download full resolution via product page](#)

### Mechanism of Action of **Teicoplanin**

Linezolid: As the first clinically available oxazolidinone, linezolid inhibits bacterial protein synthesis.[4][5][6] Uniquely, it acts at the initiation phase of this process.[5] Linezolid binds to the 23S ribosomal RNA of the 50S subunit, preventing the formation of a functional 70S initiation complex.[4][7] This blockage of protein production halts bacterial growth and replication.

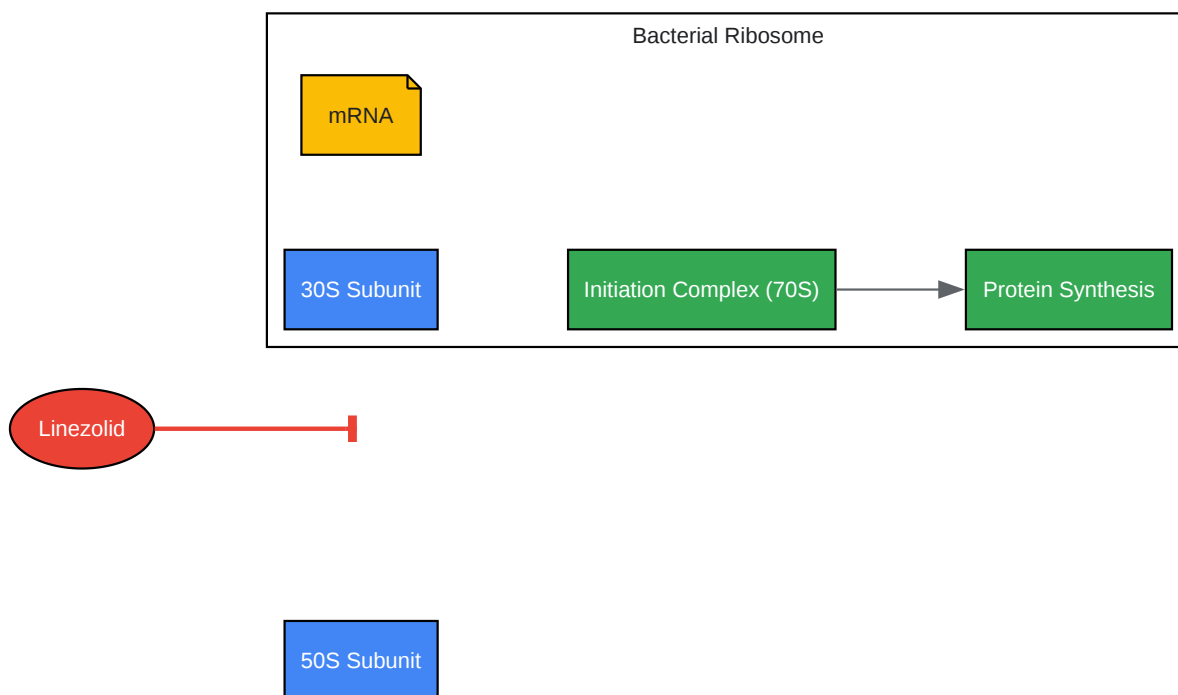

[Click to download full resolution via product page](#)

### Mechanism of Action of Linezolid

## Experimental Determination of the Post-Antibiotic Effect

The PAE is typically determined *in vitro* using the viable count method. This procedure involves several key steps to measure the suppression of bacterial growth after the removal of the antibiotic.

## Experimental Protocol

- **Bacterial Culture Preparation:** A standardized inoculum of the test bacterium (e.g., *Staphylococcus aureus*, *Enterococcus faecium*) is prepared, typically in the logarithmic phase of growth.

- **Antibiotic Exposure:** The bacterial culture is divided into test and control groups. The test group is exposed to a specific concentration of the antibiotic (e.g., a multiple of the Minimum Inhibitory Concentration, MIC) for a defined period, usually 1 to 2 hours. The control group is incubated under the same conditions without the antibiotic.
- **Antibiotic Removal:** After the exposure period, the antibiotic is removed from the test culture. This is commonly achieved by repeated centrifugation and washing of the bacterial cells with sterile, antibiotic-free medium or by significant dilution of the culture.
- **Monitoring Bacterial Regrowth:** Both the test and control cultures are then incubated, and the number of viable bacteria (Colony Forming Units per milliliter, CFU/mL) is determined at regular intervals.
- **Calculation of PAE:** The PAE is calculated using the formula:  $PAE = T - C$ , where:
  - T is the time required for the CFU/mL in the test culture to increase by 1 log<sub>10</sub> above the count immediately after antibiotic removal.
  - C is the time required for the CFU/mL in the control culture to increase by 1 log<sub>10</sub>.

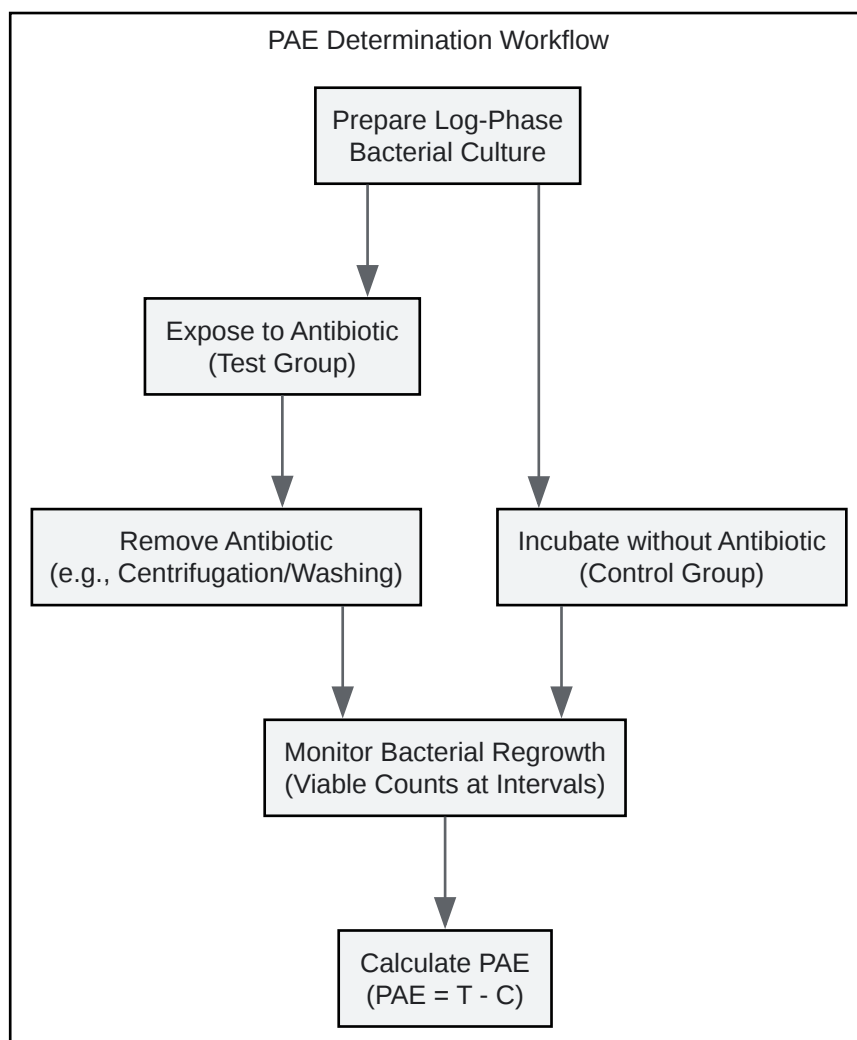

[Click to download full resolution via product page](#)

#### Experimental Workflow for PAE Determination

## Comparative PAE Data: Teicoplanin vs. Linezolid

Direct comparative studies evaluating the PAE of **teicoplanin** and linezolid under identical experimental conditions are limited. The following table summarizes data from separate studies, which should be interpreted with caution due to variations in methodology, bacterial strains, and antibiotic concentrations.

Antibiotic	Bacterial Species	Concentration (x MIC)	Exposure Time (hours)	Post-Antibiotic Effect (PAE) (hours)
Teicoplanin	Staphylococcus aureus (MSSA & MRSA)	Not specified	Not specified	2.4 - 4.1
Linezolid	Staphylococcus aureus	1	1	0 - 1.7
Staphylococcus aureus	4	1	0.5 - 2.4	
Staphylococcus epidermidis	1	1	0 - 1.7	
Staphylococcus epidermidis	4	1	0.5 - 2.4	
Enterococcus faecalis	1	1	0 - 1.7	
Enterococcus faecalis	4	1	0.5 - 2.4	

Data compiled from multiple sources. A direct comparison should be made with caution.

## Discussion of Findings

The available data suggests that **teicoplanin** generally exhibits a longer PAE against *Staphylococcus aureus* compared to linezolid. Studies have reported a PAE for **teicoplanin** ranging from 2.4 to 4.1 hours against both methicillin-sensitive and methicillin-resistant *S. aureus*.

In contrast, linezolid demonstrates a more moderate PAE. For *S. aureus*, *S. epidermidis*, and *E. faecalis*, the PAE of linezolid is concentration-dependent, increasing from 0-1.7 hours at 1x MIC to 0.5-2.4 hours at 4x MIC after a one-hour exposure. The resistance phenotype (e.g., methicillin resistance in staphylococci or vancomycin resistance in enterococci) does not appear to significantly affect the duration of the PAE for linezolid.

It is important to note that the longer PAE of **teicoplanin** may be attributed to its mechanism of action, which involves binding to and disrupting the bacterial cell wall, a structure that requires significant time for repair. Linezolid's inhibition of protein synthesis, while effective, may allow for a more rapid resumption of growth once the drug is removed and protein synthesis can recommence.

## Conclusion

Both **teicoplanin** and linezolid are crucial antibiotics in the treatment of Gram-positive infections. Based on the available, albeit non-comparative, data, **teicoplanin** appears to have a longer post-antibiotic effect against *Staphylococcus aureus* than linezolid. The PAE of linezolid is moderate and concentration-dependent.

For researchers and drug development professionals, these findings underscore the importance of conducting direct comparative studies of the pharmacodynamic properties of antibiotics. A more comprehensive understanding of the PAE can inform the development of optimized dosing strategies that maximize efficacy, minimize the development of resistance, and improve patient outcomes. Future studies should aim to directly compare the PAE of **teicoplanin** and linezolid against a panel of clinically relevant Gram-positive isolates under standardized experimental conditions.

### Need Custom Synthesis?

BenchChem offers custom synthesis for rare earth carbides and specific isotopic labeling.

Email: [info@benchchem.com](mailto:info@benchchem.com) or [Request Quote Online](#).

## References

- 1. What is the mechanism of Teicoplanin? [synapse.patnap.com]
- 2. Teicoplanin - Wikipedia [en.wikipedia.org]
- 3. go.drugbank.com [go.drugbank.com]
- 4. Linezolid - StatPearls - NCBI Bookshelf [ncbi.nlm.nih.gov]
- 5. Linezolid - Wikipedia [en.wikipedia.org]
- 6. What is the mechanism of Linezolid? [synapse.patnap.com]

- 7. [go.drugbank.com](https://go.drugbank.com) [[go.drugbank.com](https://go.drugbank.com)]
- To cite this document: BenchChem. [A Comparative Analysis of the Post-Antibiotic Effect of Teicoplanin and Linezolid]. BenchChem, [2025]. [Online PDF]. Available at: [<https://www.benchchem.com/product/b549275#comparing-the-post-antibiotic-effect-of-teicoplanin-and-linezolid>]

---

### Disclaimer & Data Validity:

The information provided in this document is for Research Use Only (RUO) and is strictly not intended for diagnostic or therapeutic procedures. While BenchChem strives to provide accurate protocols, we make no warranties, express or implied, regarding the fitness of this product for every specific experimental setup.

**Technical Support:** The protocols provided are for reference purposes. Unsure if this reagent suits your experiment? [[Contact our Ph.D. Support Team for a compatibility check](#)]

**Need Industrial/Bulk Grade?** [Request Custom Synthesis Quote](#)

## BenchChem

Our mission is to be the trusted global source of essential and advanced chemicals, empowering scientists and researchers to drive progress in science and industry.

### Contact

Address: 3281 E Guasti Rd

Ontario, CA 91761, United States

Phone: (601) 213-4426

Email: [info@benchchem.com](mailto:info@benchchem.com)