

troubleshooting unexpected side reactions with triethylamine hydrochloride

Author: BenchChem Technical Support Team. **Date:** December 2025

Compound of Interest

Compound Name: Triethylamine hydrochloride

Cat. No.: B054416

[Get Quote](#)

Technical Support Center: Troubleshooting Triethylamine Hydrochloride

Welcome to the technical support center for troubleshooting issues related to **triethylamine hydrochloride** (TEA·HCl). This resource is designed for researchers, scientists, and drug development professionals to quickly diagnose and resolve unexpected side reactions and challenges encountered during chemical synthesis.

Frequently Asked Questions (FAQs)

Q1: What is **triethylamine hydrochloride**, and why is it appearing in my reaction?

A1: **Triethylamine hydrochloride** (TEA·HCl) is the salt formed from the reaction between the base triethylamine (TEA) and hydrogen chloride (HCl).[1][2] In many organic reactions, such as the formation of esters or amides from acyl chlorides, HCl is generated as a byproduct.[1][2][3] Triethylamine is commonly added as an "acid scavenger" to neutralize this HCl, preventing it from causing unwanted side reactions or degrading the product. This neutralization is often essential for the reaction to proceed to completion.[2] The resulting TEA·HCl salt often precipitates as a white solid if the reaction is conducted in a solvent where it is insoluble (e.g., diethyl ether, THF).[1][2]

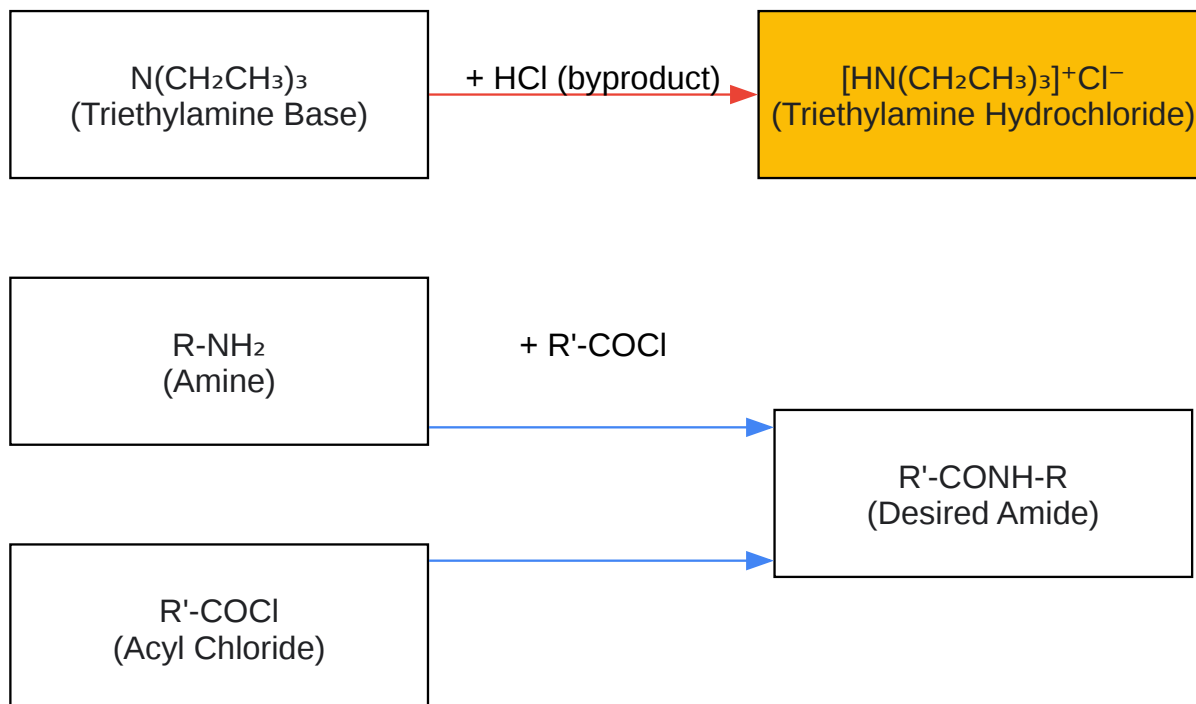

Diagram 1: Formation of TEA·HCl in an Amidation Reaction

[Click to download full resolution via product page](#)

Caption: General formation of TEA·HCl byproduct during a typical amidation reaction.

Q2: I observe an unexpected solid precipitating from my reaction mixture. Could it be a side reaction product?

A2: While other side reactions are possible, the most common cause for a white precipitate when using triethylamine in reactions that generate acid is the formation of **triethylamine hydrochloride**. TEA·HCl is often insoluble in common aprotic organic solvents such as diethyl ether, tetrahydrofuran (THF), dioxane, and ethyl acetate.^[1] Its precipitation is an expected outcome of its formation.

Q3: My product is sensitive to water. How can I remove the TEA·HCl byproduct without an aqueous workup?

A3: For moisture-sensitive compounds, non-aqueous methods are essential. Two primary strategies can be employed:

- **Direct Filtration:** Conduct the reaction in a solvent in which your product is soluble but TEA·HCl is not (e.g., diethyl ether, THF).^{[1][4]} Once the reaction is complete, the solid TEA·HCl can be directly removed by filtration. Cooling the mixture can help maximize precipitation.^[1]
- **Solvent Swap & Filtration:** If your reaction requires a solvent in which TEA·HCl has some solubility (like dichloromethane), you can first remove the reaction solvent under reduced pressure. Subsequently, add a solvent in which your product is soluble but the salt is not (e.g., diethyl ether, hexane, or ethyl acetate).^[1] This will cause the salt to precipitate, allowing for its removal by filtration.

Q4: The TEA·HCl salt is not precipitating, or my reaction has formed an emulsion during workup. What should I do?

A4: If the salt remains dissolved, it is likely because it has some solubility in your solvent system. To force precipitation, you can:

- **Add an Anti-Solvent:** Gradually add a non-polar solvent in which TEA·HCl is known to be insoluble, such as hexane or heptane.^[1]
- **Cool the Mixture:** Lowering the temperature can reduce the salt's solubility.^[1]
- **Concentrate the Solution:** Reducing the solvent volume via rotary evaporation can cause the salt to precipitate.^[1]

Emulsions can sometimes form during aqueous workups with TEA·HCl. Adding brine (a saturated aqueous solution of NaCl) can often help break the emulsion and improve phase separation.

Q5: Could residual TEA·HCl be catalyzing an unwanted side reaction?

A5: Yes, this is possible. While primarily known as a byproduct, TEA·HCl can act as a catalyst in certain reactions. For instance, it has been shown to catalyze the melt polymerization of carbonate monomers.^[5] If you are working with sensitive monomers or observing unexpected polymerization, residual TEA·HCl could be the cause. Its complete removal during purification is critical in such cases.

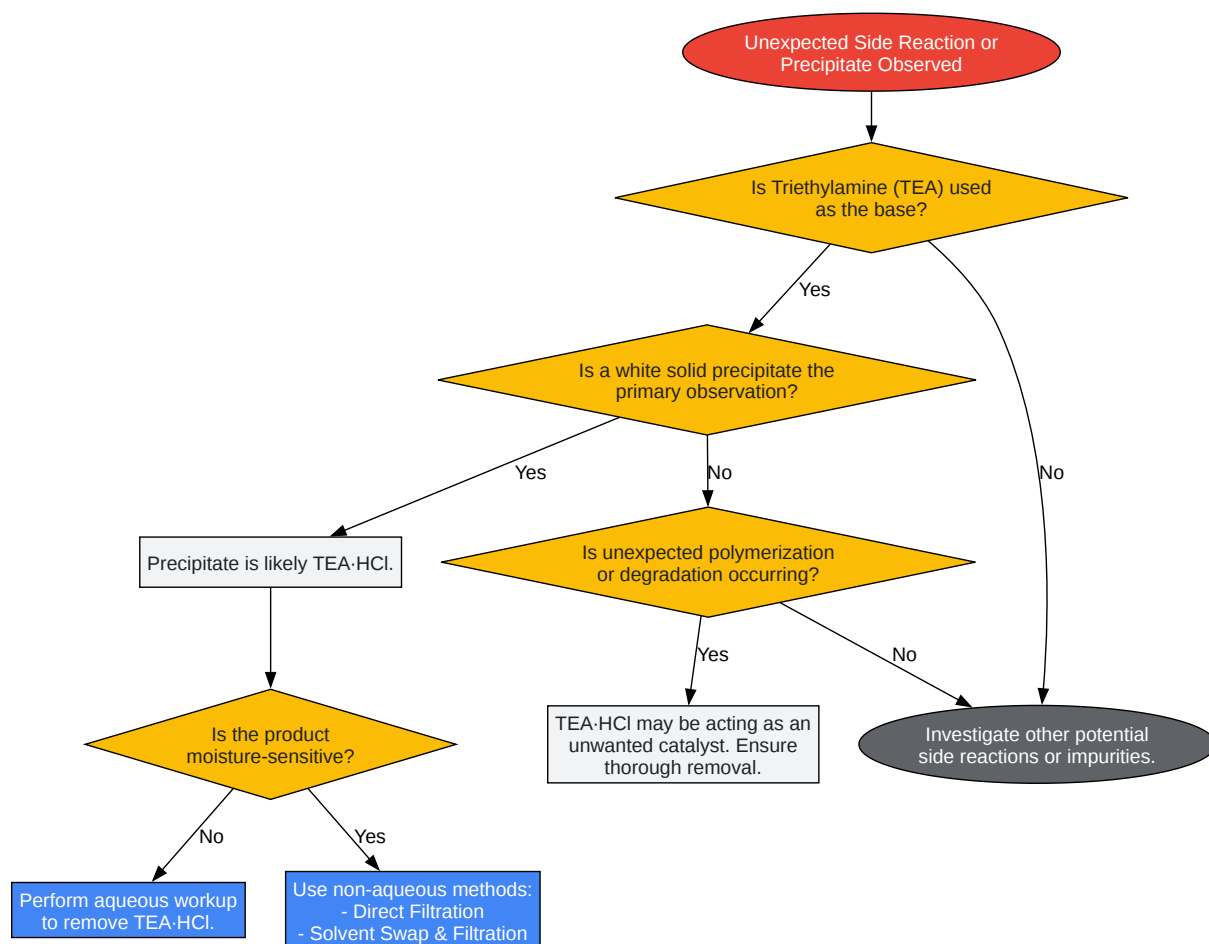

Diagram 2: Troubleshooting Logic for TEA-HCl Issues

[Click to download full resolution via product page](#)

Caption: A decision-making workflow for troubleshooting common TEA-HCl issues.

Q6: I am performing peptide synthesis and observing side reactions. Could the use of triethylamine be the cause?

A6: Yes. In peptide synthesis, triethylamine is often used in capping steps (e.g., with acetic anhydride, Ac_2O) or for neutralization.[6] Side reactions such as the acetylation of arginine residues have been observed when using an $\text{Ac}_2\text{O}/\text{Et}_3\text{N}$ mixture.[6] The choice of base and reaction conditions is critical to avoid such unwanted modifications to the peptide chain.[7][8]

Data & Physical Properties

For effective troubleshooting and purification, understanding the solubility of **triethylamine hydrochloride** is crucial.

Table 1: Solubility of **Triethylamine Hydrochloride** in Various Solvents

Solvent	Solubility	Temperature (°C)	Notes
Water	1440 g/L	20	Highly soluble, making aqueous workups very effective.[9]
Ethanol	Soluble	-	Good solubility.
Diethyl Ether	Insoluble	-	Ideal for precipitating and filtering the salt. [9]
Chloroform	Soluble	-	TEA·HCl is soluble, requiring alternative removal methods.[10]
Tetrahydrofuran (THF)	Insoluble	-	A common choice for reactions where TEA·HCl precipitation is desired.[1][4]
Dichloromethane (DCM)	Soluble	-	Similar to chloroform; filtration is not a suitable removal method.
Hexane / Heptane	Insoluble	-	Often used as anti-solvents to force precipitation.[1]
Ethyl Acetate	Insoluble	-	Can be used to precipitate the salt.[1] [4]

Experimental Protocols

Protocol 1: Removal of TEA·HCl via Aqueous Workup

This protocol is suitable for water-insensitive products in a water-immiscible organic solvent (e.g., Dichloromethane, Ethyl Acetate).

- **Transfer:** Transfer the entire reaction mixture to a separatory funnel.
- **Wash:** Add an equal volume of a dilute aqueous acid solution (e.g., 1N HCl). This ensures any remaining free triethylamine base is converted to the water-soluble salt. Stopper the funnel and shake vigorously for 30-60 seconds, venting periodically.
- **Separate:** Allow the layers to separate. Drain and discard the lower aqueous layer.
- **Repeat:** Repeat the wash with water, followed by a wash with brine to aid in the removal of dissolved water from the organic layer.
- **Dry:** Drain the organic layer into a clean flask and dry it over an anhydrous drying agent (e.g., Na_2SO_4 or MgSO_4).
- **Isolate:** Filter or decant the dried organic solution and remove the solvent under reduced pressure to yield the crude product.^[1]

Protocol 2: Removal of TEA·HCl by Filtration (for Moisture-Sensitive Reactions)

This protocol is ideal for reactions performed in solvents where TEA·HCl is insoluble (e.g., THF, Diethyl Ether).

- **Cool:** Once the reaction is deemed complete (e.g., by TLC monitoring), cool the mixture in an ice bath to maximize the precipitation of the TEA·HCl salt.
- **Set up Filtration:** Set up a Büchner or Hirsch funnel with an appropriate filter paper.
- **Filter:** Filter the reaction mixture under vacuum.
- **Wash:** Wash the collected solid (the TEA·HCl) with a small amount of the cold reaction solvent to recover any product that may have adhered to it.
- **Collect:** The filtrate contains your desired product. Concentrate the filtrate under reduced pressure to isolate the crude product. The product can then be further purified if necessary (e.g., by column chromatography).^[1]

Protocol 3: Detection and Quantification of Residual Triethylamine

For applications requiring strict purity control, residual triethylamine (from the salt) can be quantified. Headspace gas chromatography (HS-GC) is a precise method for this.

- **Sample Prep:** A sample is dissolved in a vial containing a high-boiling solvent like dimethyl sulfoxide (DMSO) and a stronger base, such as imidazole, to liberate the free triethylamine from its salt form.[11][12]
- **Incubation:** The vial is heated (e.g., 100°C for 20 minutes) to allow the volatile triethylamine to partition into the headspace (the gas phase above the liquid).[11]
- **Injection:** A sample of the headspace gas is automatically injected into the gas chromatograph.
- **Separation & Detection:** The sample is separated on a suitable column (e.g., DB624) and detected by a flame ionization detector (FID).[11]
- **Quantification:** The amount of triethylamine is determined by comparing the peak area to that of a known standard.[11]

Need Custom Synthesis?

BenchChem offers custom synthesis for rare earth carbides and specific isotopic labeling.

Email: info@benchchem.com or [Request Quote Online](#).

References

1. benchchem.com [benchchem.com]
2. Triethylamine Hydrochloride | High-Purity Reagent [benchchem.com]
3. Triethylamine hydrochloride Exporter | Triethylamine hydrochloride Exporting Company | Triethylamine hydrochloride International Distributor [multichemexports.com]
4. researchgate.net [researchgate.net]
5. Triethylamine-based catalysts for the melt polymerization of carbonate monomers - Polymer Chemistry (RSC Publishing) [pubs.rsc.org]
6. Side reactions in solid-phase peptide synthesis and their applications - PubMed [pubmed.ncbi.nlm.nih.gov]

- 7. BiblioMed.org - Fulltext article Viewer [bibliomed.org]
- 8. Spps and side reactions in peptide synthesis | PPTX [slideshare.net]
- 9. lobachemie.com [lobachemie.com]
- 10. Triethylamine hydrochloride | 554-68-7 [chemicalbook.com]
- 11. ijpsonline.com [ijpsonline.com]
- 12. [PDF] Determination of Dimethylamine and Triethylamine in Hydrochloride Salts of Drug Substances by Headspace Gas Chromatography using Dimethyl Sulphoxide- imidazole as Diluent | Semantic Scholar [semanticscholar.org]
- To cite this document: BenchChem. [troubleshooting unexpected side reactions with triethylamine hydrochloride]. BenchChem, [2025]. [Online PDF]. Available at: [https://www.benchchem.com/product/b054416#troubleshooting-unexpected-side-reactions-with-triethylamine-hydrochloride]

Disclaimer & Data Validity:

The information provided in this document is for Research Use Only (RUO) and is strictly not intended for diagnostic or therapeutic procedures. While BenchChem strives to provide accurate protocols, we make no warranties, express or implied, regarding the fitness of this product for every specific experimental setup.

Technical Support: The protocols provided are for reference purposes. Unsure if this reagent suits your experiment? [[Contact our Ph.D. Support Team for a compatibility check](#)]

Need Industrial/Bulk Grade? [Request Custom Synthesis Quote](#)

BenchChem

Our mission is to be the trusted global source of essential and advanced chemicals, empowering scientists and researchers to drive progress in science and industry.

Contact

Address: 3281 E Guasti Rd
Ontario, CA 91761, United States
Phone: (601) 213-4426
Email: info@benchchem.com