

Application Note: Protocol for Assessing the Oral Bioavailability of Piperidine Derivatives

Author: BenchChem Technical Support Team. **Date:** April 2026

Compound of Interest

Compound Name: 3-[2-(3-fluorophenyl)ethyl]piperidine

Cat. No.: B5364731

[Get Quote](#)

Executive Summary: The Piperidine Challenge

Piperidine moieties are ubiquitous in medicinal chemistry, serving as the core pharmacophore for diverse drugs ranging from analgesics (Fentanyl) to antidepressants (Paroxetine). However, the piperidine ring introduces specific bioavailability challenges that generic ADME protocols often miss.

The "Piperidine Paradox": While the secondary or tertiary amine function usually ensures good aqueous solubility at gastric pH (pKa ~9–11), it creates three distinct liabilities for oral bioavailability (

):

- Lysosomotropic Trapping: The basic amine leads to accumulation in acidic lysosomes, artificially inflating Volume of Distribution () and reducing free fraction in plasma.
- P-gp Efflux: Many lipophilic piperidines are substrates for P-glycoprotein (MDR1), limiting intestinal absorption.

- Metabolic Soft Spots: The

-carbon adjacent to the nitrogen is highly susceptible to CYP450-mediated oxidation (N-dealkylation or ring hydroxylation).

This application note details a specialized protocol designed to isolate and quantify these factors to accurately predict and assess oral bioavailability.

Assessment Workflow Visualization

The following flowchart outlines the logic gate for assessing piperidine derivatives, prioritizing the identification of metabolic and distribution liabilities early in the process.

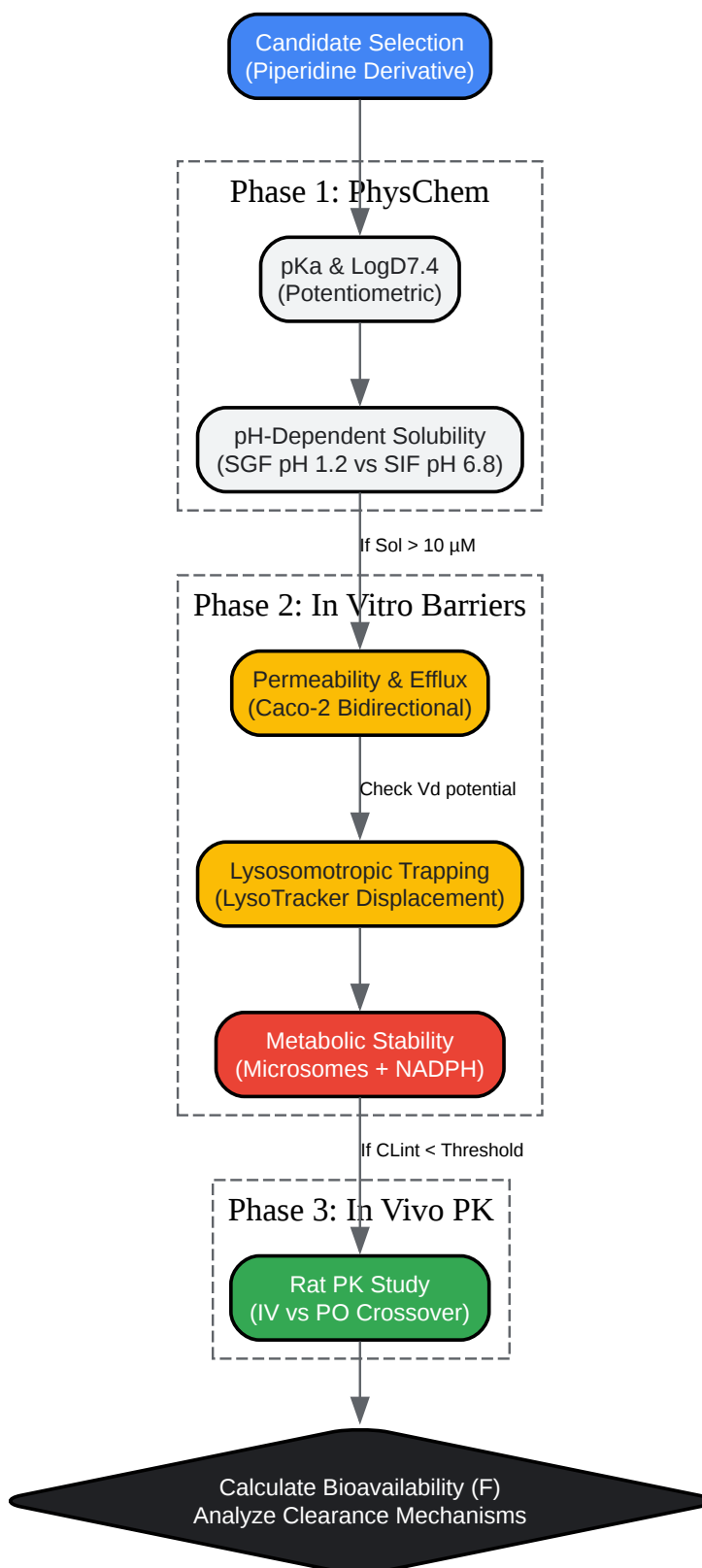

[Click to download full resolution via product page](#)

Figure 1: Step-wise logic flow for characterizing piperidine bioavailability, moving from physicochemical properties to in vivo validation.

Phase 1: Physicochemical Profiling (The Ionization Trap)

Piperidines are bases.[1] At physiological pH (7.4), they exist in equilibrium between cationic and neutral forms. Bioavailability is often limited not by intrinsic solubility, but by the precipitation of the free base as the drug transitions from the acidic stomach (pH 1.2) to the neutral small intestine (pH 6.8).

Protocol: pH-Shift Solubility Assay

Objective: Mimic the transition from gastric to intestinal environment.

- Preparation: Dissolve compound in Simulated Gastric Fluid (SGF, pH 1.2) to saturation. Incubate for 1 hour at 37°C.
- The Shift: Dilute the SGF solution 1:5 into Simulated Intestinal Fluid (SIF, pH 6.8) containing bile salts (FaSSIF).
- Measurement: Monitor for precipitation using kinetic nephelometry or UV-spectroscopy over 4 hours.
- Acceptance Criteria: A compound must maintain supersaturation for >2 hours to ensure sufficient absorption window in the duodenum/jejunum.

Phase 2: In Vitro Permeability & Distribution Bidirectional Caco-2 Permeability (Efflux Check)

Piperidines are frequent substrates for P-gp. A unidirectional assay (PAMPA) is insufficient.

Protocol Steps:

- Cell Culture: Seed Caco-2 cells on Transwell® polycarbonate filters (0.4 µm pore size). Culture for 21 days to allow differentiation and transporter expression.[2]

- Integrity Check: Measure Transepithelial Electrical Resistance (TEER). Only monolayers with TEER > 300

are valid.

- Dosing:
 - Apical to Basolateral (A-B): Mimics absorption.[3] Add 10 μ M compound to Apical chamber.
 - Basolateral to Apical (B-A): Mimics efflux.[3][4] Add 10 μ M compound to Basolateral chamber.
- Incubation: 2 hours at 37°C with shaking (60 rpm).
- Analysis: Quantify donor and receiver samples via LC-MS/MS.
- Calculation:

Interpretation: An ER > 2.0 indicates active efflux (likely P-gp).[4] Co-incubate with Verapamil (P-gp inhibitor) to confirm.

Lysosomotropic Trapping Assay (The Piperidine Specific)

Why this matters: Basic piperidines get trapped in acidic lysosomes (pH ~4.5), leading to a high volume of distribution (

) but low free drug concentration in plasma. This mimics "high tissue distribution" but is actually sequestration.

Protocol Steps:

- Cell Line: Use Fa2N-4 hepatocytes or H9c2 cells.
- Probe: Load cells with LysoTracker™ Red (50 nM), a fluorescent dye that localizes to acidic organelles.

- Treatment: Treat cells with the piperidine derivative (graded concentrations: 1–100 μM) for 30 minutes.
- Readout: If the piperidine accumulates in lysosomes, it raises the lysosomal pH or displaces the dye. Measure the decrease in intracellular fluorescence using a flow cytometer or high-content imager.
- Control: Use Chloroquine (known lysosomotropic agent) as a positive control.

Phase 3: Metabolic Stability (The "Soft Spot")

The piperidine ring is metabolically labile. The primary clearance pathway is usually oxidation at the

α -carbon (adjacent to nitrogen) mediated by CYP3A4 or CYP2D6.

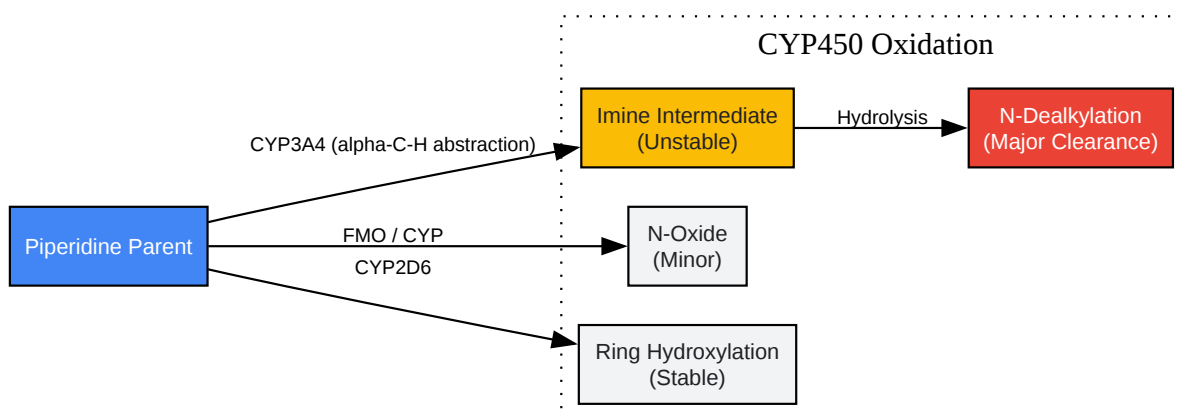

[Click to download full resolution via product page](#)

Figure 2: Common metabolic fates of the piperidine ring. N-dealkylation is often the rate-limiting step for bioavailability.

Microsomal Stability Protocol:

- System: Pooled Human Liver Microsomes (HLM) (0.5 mg/mL protein).

- Reaction: Pre-incubate microsomes + compound (1 μ M) for 5 min at 37°C. Initiate with NADPH-regenerating system.
- Sampling: Quench aliquots at 0, 5, 15, 30, and 60 mins into ice-cold acetonitrile (containing internal standard).
- Calculation: Plot $\ln(\% \text{ remaining})$ vs. time. The slope is .
- High Clearance Warning: If min, oral bioavailability will likely be due to first-pass metabolism.

Phase 4: In Vivo Pharmacokinetics (Rat)

To definitively calculate

, an intravenous (IV) vs. oral (PO) crossover study is required.

Study Design:

- Species: Sprague-Dawley Rats (cannulated).
- N: 3 animals per group.
- Formulation:
 - IV: Saline or 5% Dextrose (pH adjusted to 5-6 to ensure solubility).
 - PO: 0.5% Methylcellulose (suspension) or Citrate Buffer (solution).
- Dosing:
 - IV Dose: 1 mg/kg (Bolus).
 - PO Dose: 5 mg/kg (Gavage).

- Sampling: Serial blood draws at 0.083, 0.25, 0.5, 1, 2, 4, 8, 24 hours.

Data Analysis (The Calculation): Oral bioavailability (

) is calculated using the dose-normalized Area Under the Curve (AUC):

Data Presentation Table:

Parameter	Unit	Definition	Piperidine "Red Flag"
	ng/mL	Peak concentration	Low often indicates poor solubility or high first-pass.
	h	Time to peak	Delayed suggests precipitation in the stomach.
	L/kg	Vol. of Distribution	> 5 L/kg suggests lysosomotropic trapping.
	mL/min/kg	Systemic Clearance	Approaching hepatic blood flow (55 mL/min/kg in rat) indicates rapid metabolism.
	%	Bioavailability	< 20% usually requires structural optimization.

References

- FDA Guidance for Industry. (2018). Bioanalytical Method Validation. U.S. Department of Health and Human Services.[5][6] [\[Link\]](#)

- Lipinski, C. A., et al. (2001). Experimental and computational approaches to estimate solubility and permeability in drug discovery and development settings. *Advanced Drug Delivery Reviews*. [[Link](#)]
- Fu, Z., et al. (2020).[7] Coupled electron and proton transfer in the piperidine drug metabolism pathway by the active species of cytochromes P450.[7][8] *Dalton Transactions*. [[Link](#)]
- Kazmi, F., et al. (2013). Lysosomal sequestration of weak bases: a practical approach to predict the extent of subcellular distribution. *Drug Metabolism and Disposition*. [[Link](#)]
- Oshida, K., et al. (2023).[1] Lysosomal trapping of 4-dimethylamino-1-{3-(1-methyl-1H-imidazole-2-yl)propanoyl}piperidine... in human aortic vascular smooth muscle cells.[1][9] *Toxicology in Vitro*. [[Link](#)]

Need Custom Synthesis?

BenchChem offers custom synthesis for rare earth carbides and specific isotopic labeling.

Email: info@benchchem.com or [Request Quote Online](#).

Sources

- 1. Lysosomal trapping of 4-dimethylamino-1-{3-(1-methyl-1H-imidazole-2-yl)propanoyl}piperidine, a hydrophilic and weakly basic amine, in human aortic vascular smooth muscle cells - PubMed [pubmed.ncbi.nlm.nih.gov]
- 2. dda.creative-bioarray.com [dda.creative-bioarray.com]
- 3. Caco-2 Permeability Assay | Domainex [domainex.co.uk]
- 4. Caco-2 Permeability | Evotec [evotec.com]
- 5. fda.gov [fda.gov]
- 6. Federal Register :: Bioanalytical Method Validation; Guidance for Industry; Availability [federalregister.gov]
- 7. experts.umn.edu [experts.umn.edu]
- 8. Coupled electron and proton transfer in the piperidine drug metabolism pathway by the active species of cytochromes P450 - Dalton Transactions (RSC Publishing) [pubs.rsc.org]

- [9. researchgate.net \[researchgate.net\]](#)
- To cite this document: BenchChem. [Application Note: Protocol for Assessing the Oral Bioavailability of Piperidine Derivatives]. BenchChem, [2026]. [Online PDF]. Available at: [<https://www.benchchem.com/product/b5364731/docs#application-note-protocol-for-assessing-the-oral-bioavailability-of-piperidine-derivatives>]

Disclaimer & Data Validity:

The information provided in this document is for Research Use Only (RUO) and is strictly not intended for diagnostic or therapeutic procedures. While BenchChem strives to provide accurate protocols, we make no warranties, express or implied, regarding the fitness of this product for every specific experimental setup.

Technical Support: The protocols provided are for reference purposes. Unsure if this reagent suits your experiment?

Need Industrial/Bulk Grade? [Request Custom Synthesis Quote](#)

BenchChem

Our mission is to be the trusted global source of essential and advanced chemicals, empowering scientists and researchers to drive progress in science and industry.

Contact

Address: 3281 E Guasti Rd
Ontario, CA 91761, United States
Phone: (601) 213-4426
Email: info@benchchem.com

[Contact our Ph.D. Support Team for a compatibility check](#)