

# Technical Support Center: Synthesis of 4-Chloro-3-methylbenzaldehyde

**Author:** BenchChem Technical Support Team. **Date:** May 2026

## Compound of Interest

Compound Name: 4-Chloro-3-methylbenzaldehyde

CAS No.: 101349-71-7

Cat. No.: B052831

[Get Quote](#)

This technical support center provides troubleshooting guides and frequently asked questions (FAQs) to assist researchers, scientists, and drug development professionals in optimizing the synthesis of **4-Chloro-3-methylbenzaldehyde**. The information is presented in a question-and-answer format, addressing specific issues that may be encountered during experimentation.

## Frequently Asked Questions (FAQs) & Troubleshooting Guides

This section is organized by the synthetic method.

### Vilsmeier-Haack Formylation of 2-Chlorotoluene

The Vilsmeier-Haack reaction is a versatile method for the formylation of electron-rich aromatic compounds. In this case, 2-chlorotoluene is reacted with a Vilsmeier reagent, typically formed from N,N-dimethylformamide (DMF) and phosphorus oxychloride (POCl<sub>3</sub>), to introduce a formyl group.

Q1: My Vilsmeier-Haack reaction is showing low to no yield of **4-Chloro-3-methylbenzaldehyde**. What are the possible causes and how can I improve the conversion?

A1: Low yields in the Vilsmeier-Haack formylation of 2-chlorotoluene can be attributed to several factors, primarily the deactivating effect of the chlorine atom on the aromatic ring. Here are some troubleshooting steps:

- **Reagent Quality:** Ensure that all reagents, especially DMF and POCl<sub>3</sub>, are anhydrous and of high purity. The Vilsmeier reagent is highly sensitive to moisture.
- **Reaction Temperature:** While the initial formation of the Vilsmeier reagent should be performed at low temperatures (0-5 °C), the formylation of a less reactive substrate like 2-chlorotoluene may require heating. Gradually increase the reaction temperature (e.g., to 70-80 °C) and monitor the progress by TLC.
- **Stoichiometry:** An excess of the Vilsmeier reagent may be necessary to drive the reaction to completion with a deactivated substrate. However, a large excess can lead to side reactions. It is advisable to start with a 1.5 to 2-fold excess of the Vilsmeier reagent.
- **Reaction Time:** Deactivated substrates require longer reaction times. Monitor the reaction's progress using TLC to determine the optimal reaction time.

Q2: I am observing the formation of multiple products in my reaction mixture. How can I improve the selectivity for **4-Chloro-3-methylbenzaldehyde**?

A2: The formation of multiple products can be due to di-formylation or formylation at other positions on the aromatic ring. To enhance selectivity:

- **Control Stoichiometry:** Carefully control the molar ratio of the Vilsmeier reagent to 2-chlorotoluene. Using a large excess can promote the formation of di-formylated byproducts.
- **Temperature Control:** Maintain a consistent and optimized reaction temperature. Overheating can lead to undesired side reactions.
- **Slow Addition:** Add the 2-chlorotoluene solution dropwise to the prepared Vilsmeier reagent to maintain a low concentration of the substrate and favor mono-formylation.

Q3: The reaction mixture has turned into a dark, tarry residue. What went wrong?

A3: The formation of a tarry residue often indicates decomposition or polymerization, which can be caused by:

- **Overheating:** The reaction is exothermic, and poor temperature control can lead to uncontrolled side reactions.
- **Impurities:** The presence of impurities in the starting materials or solvents can catalyze polymerization.
- **Concentrated Reagents:** Using highly concentrated reagents can lead to localized overheating.

To avoid this, ensure strict temperature control, use pure and anhydrous reagents and solvents, and consider using a suitable inert solvent to aid in heat dissipation.

## Gattermann-Koch Formylation of 2-Chlorotoluene

The Gattermann-Koch reaction introduces a formyl group onto an aromatic ring using carbon monoxide (CO) and hydrogen chloride (HCl) in the presence of a Lewis acid catalyst, such as aluminum chloride (AlCl<sub>3</sub>), and a co-catalyst, typically copper(I) chloride (CuCl).

Q1: My Gattermann-Koch reaction is not proceeding, or the yield is very low. What are the critical factors for this reaction?

A1: The Gattermann-Koch reaction is sensitive to several factors:

- **Catalyst Activity:** Ensure that the aluminum chloride is anhydrous and highly active. Exposure to moisture will deactivate the catalyst.
- **Purity of Gases:** Use dry hydrogen chloride gas and high-purity carbon monoxide.
- **Co-catalyst:** The presence of a small amount of cuprous chloride is often essential for the reaction to proceed, especially when not using high pressures of CO.
- **Reaction Conditions:** This reaction often requires high pressure of carbon monoxide to achieve good yields. If high-pressure equipment is not available, the yield may be

significantly lower.

- **Substrate Reactivity:** 2-Chlorotoluene is a somewhat deactivated substrate for this reaction, which can contribute to low yields under atmospheric pressure.

Q2: I am concerned about the safety of using carbon monoxide and hydrogen chloride. Are there any alternatives?

A2: Yes, due to the hazardous nature of CO and HCl gas, alternative formylation methods are often preferred in a laboratory setting. The Gattermann reaction, which uses a mixture of hydrogen cyanide (HCN) and HCl, is one such alternative. However, HCN is also highly toxic. A safer modification, known as the Adams modification, generates HCN in situ from zinc cyanide ( $\text{Zn}(\text{CN})_2$ ) and HCl.<sup>[1][2]</sup>

Q3: What are the common side products in the Gattermann-Koch reaction with 2-chlorotoluene?

A3: Common side products can include:

- **Isomeric Products:** Although the formylation is directed by the methyl and chloro groups, small amounts of other isomers may form.
- **Di-formylated Products:** Under harsh conditions or with prolonged reaction times, di-formylation can occur.
- **Rearrangement Products:** While less common for this substrate, Friedel-Crafts type reactions can sometimes lead to rearrangement of alkyl groups under strong Lewis acid conditions.

## Sommelet Reaction of 4-Chloro-3-methylbenzyl Halide

The Sommelet reaction converts a benzyl halide to the corresponding aldehyde using hexamine (hexamethylenetetramine) and water.<sup>[3]</sup>

Q1: The yield of my Sommelet reaction is consistently below 50%. How can I improve it?

A1: Several factors can influence the yield of the Sommelet reaction:

- **Starting Material Purity:** Ensure the 4-chloro-3-methylbenzyl halide is pure and free from di-halogenated impurities.
- **Reaction Solvent:** The choice of solvent can have a significant impact. While the reaction is often carried out in aqueous or alcoholic solutions, using 50% acetic acid as a solvent has been reported to improve yields for some substrates.
- **pH Control:** After the initial reaction with hexamine, the hydrolysis step is typically carried out under acidic conditions. Careful adjustment of the pH to around 3-4 with a mineral acid like HCl is crucial for efficient hydrolysis to the aldehyde.[4]
- **Reaction Time:** The reflux time for both the formation of the hexaminium salt and the subsequent hydrolysis should be optimized. Monitor the reaction by TLC to avoid decomposition of the product with prolonged heating.

Q2: I am getting a significant amount of a nitrogen-containing byproduct. What is it and how can I avoid its formation?

A2: A common side reaction in the Sommelet reaction is the formation of the corresponding benzylamine (the Delépine reaction).[5] This can occur if the hydrolysis conditions are not optimal. To favor the formation of the aldehyde:

- **Ensure Acidic Hydrolysis:** The final hydrolysis step must be carried out in an acidic medium.
- **Control Reaction Time:** Overly long reaction times or excessively harsh conditions during hydrolysis can lead to the formation of the amine.

Q3: How can I effectively purify the **4-Chloro-3-methylbenzaldehyde** from the reaction mixture?

A3: The product is typically isolated by steam distillation from the reaction mixture.[6] Further purification can be achieved by:

- **Extraction:** Extract the distillate with a suitable organic solvent like ether or dichloromethane.
- **Washing:** Wash the organic extract with a dilute sodium carbonate or bicarbonate solution to remove any acidic impurities, followed by a brine wash.

- **Drying and Evaporation:** Dry the organic layer over an anhydrous drying agent (e.g.,  $\text{MgSO}_4$  or  $\text{Na}_2\text{SO}_4$ ) and remove the solvent under reduced pressure.
- **Distillation:** The crude product can be purified by vacuum distillation.

## Grignard Reaction

This method involves the formation of a Grignard reagent from a suitable halo-substituted precursor, followed by its reaction with a formylating agent like N,N-dimethylformamide (DMF).

Q1: I am having trouble initiating the Grignard reaction to form the organomagnesium reagent. What can I do?

A1: Difficulty in initiating a Grignard reaction is a common issue. Here are some tips:

- **Anhydrous Conditions:** Grignard reagents are extremely sensitive to moisture. Ensure all glassware is oven-dried, and use anhydrous solvents (typically THF or diethyl ether).
- **Magnesium Activation:** The surface of the magnesium turnings can be passivated by a layer of magnesium oxide. Activate the magnesium by:
  - Adding a small crystal of iodine.
  - Adding a few drops of 1,2-dibromoethane.
  - Mechanically crushing the magnesium turnings with a glass rod.
- **Initiation:** Add a small amount of the halide solution to the magnesium and gently warm the mixture. Once the reaction starts (indicated by bubbling and a cloudy appearance), add the rest of the halide solution dropwise.

Q2: My Grignard reaction with DMF is giving a low yield of the aldehyde. What are the potential pitfalls?

A2: Low yields in the formylation step can be due to:

- **Side Reactions of the Grignard Reagent:** The Grignard reagent can react with itself (Wurtz coupling) or with unreacted starting halide. Slow addition of the halide during the Grignard

formation can minimize this.

- **Reaction with the Aldehyde Product:** The Grignard reagent can add to the aldehyde product to form a secondary alcohol. To prevent this, the reaction is typically carried out at low temperatures (e.g., -78 °C to 0 °C), and the Grignard reagent is added slowly to the DMF.
- **Incomplete Reaction:** Ensure a sufficient amount of the formylating agent is used and allow the reaction to proceed for an adequate amount of time.

**Q3: Which starting material should I use to prepare the Grignard reagent for the synthesis of 4-Chloro-3-methylbenzaldehyde?**

**A3:** A suitable starting material would be 1-bromo-4-chloro-2-methylbenzene. The Grignard reagent will preferentially form at the more reactive C-Br bond, leaving the C-Cl bond intact. The resulting Grignard reagent, (4-chloro-3-methylphenyl)magnesium bromide, can then be reacted with DMF.

## Oxidation of 4-Chloro-3-methyltoluene

This method involves the selective oxidation of the methyl group of 4-chloro-3-methyltoluene to an aldehyde.

**Q1:** I am trying to oxidize 4-chloro-3-methyltoluene, but I am getting a significant amount of the corresponding carboxylic acid (4-chloro-3-methylbenzoic acid). How can I prevent over-oxidation?

**A1:** Preventing over-oxidation to the carboxylic acid is a key challenge in this synthesis. Here are some strategies:

- **Choice of Oxidizing Agent:** Use a mild and selective oxidizing agent. Common reagents for this transformation include:
  - Manganese dioxide (MnO<sub>2</sub>) in sulfuric acid.
  - Cerium(IV) ammonium nitrate (CAN).
  - Chromyl chloride (Étard reaction).

- N-Bromosuccinimide (NBS) for benzylic bromination followed by hydrolysis.
- Control of Reaction Conditions:
  - Temperature: Carry out the reaction at a controlled, and often low, temperature.
  - Stoichiometry: Use a stoichiometric amount of the oxidizing agent. An excess will promote over-oxidation.
  - Reaction Time: Monitor the reaction closely by TLC and stop it as soon as the starting material is consumed.

Q2: The oxidation reaction is very slow or incomplete. How can I improve the reaction rate without causing over-oxidation?

A2: Improving the rate of a selective oxidation requires a careful balance of conditions:

- Catalyst: Some oxidation reactions are catalyzed. For example, in aerobic oxidations, a cobalt or manganese salt can be used as a catalyst.
- Solvent: The choice of solvent can influence the reaction rate.
- Temperature: A modest increase in temperature may be necessary, but this must be done cautiously and with careful monitoring to avoid over-oxidation.

Q3: What are some recommended procedures for the purification of **4-Chloro-3-methylbenzaldehyde** from an oxidation reaction?

A3: The purification strategy will depend on the oxidizing agent used. General steps include:

- Quenching: Quench the reaction appropriately to destroy any remaining oxidizing agent.
- Extraction: Extract the product into a suitable organic solvent.
- Washing: Wash the organic layer to remove inorganic salts and byproducts. A wash with a dilute base (e.g., sodium bicarbonate solution) can remove any carboxylic acid byproduct.

- Chromatography: Column chromatography on silica gel is an effective method for separating the aldehyde from unreacted starting material and other byproducts.[7]
- Distillation: Vacuum distillation can be used for the final purification of the liquid product.

## Quantitative Data Presentation

The following tables summarize typical yields for the synthesis of aromatic aldehydes using the discussed methods. Note that yields can vary significantly based on the specific substrate, reaction conditions, and scale.

Table 1: Comparison of Yields for Different Synthetic Methods

Synthetic Method	Starting Material	Typical Yield Range (%)	Notes
Vilsmeier-Haack	2-Chlorotoluene	40-60%	Yield is sensitive to substrate reactivity; optimization of temperature and stoichiometry is crucial.
Gattermann-Koch	2-Chlorotoluene	30-50% (at atm. pressure)	Higher yields are possible with high-pressure equipment. Deactivated substrate leads to lower yields.
Sommelet Reaction	4-Chloro-3-methylbenzyl chloride	60-80%	A reliable method for benzylic halides. Yields can be optimized by solvent choice and pH control during hydrolysis.[8]
Grignard Reaction	1-Bromo-4-chloro-2-methylbenzene	65-85%	Good yields are achievable with careful control of anhydrous conditions and low temperature during formylation.
Oxidation	4-Chloro-3-methyltoluene	50-70%	Yield is highly dependent on the selectivity of the oxidizing agent and control of reaction conditions to prevent over-oxidation.

## Experimental Protocols

### Protocol 1: Vilsmeier-Haack Formylation of 2-Chlorotoluene

- To a stirred solution of anhydrous N,N-dimethylformamide (1.5 eq.) in an appropriate anhydrous solvent (e.g., dichloromethane) at 0 °C under an inert atmosphere, add phosphorus oxychloride (1.1 eq.) dropwise, maintaining the temperature below 5 °C.
- Stir the mixture at 0 °C for 30 minutes to form the Vilsmeier reagent.
- Add a solution of 2-chlorotoluene (1.0 eq.) in the same anhydrous solvent to the Vilsmeier reagent at 0 °C.
- Allow the reaction mixture to warm to room temperature and then heat to 50-60 °C for 4-6 hours, monitoring the progress by TLC.
- After completion, cool the reaction mixture and pour it onto crushed ice.
- Neutralize the mixture with a saturated solution of sodium bicarbonate.
- Extract the product with dichloromethane, wash the organic layer with brine, dry over anhydrous sodium sulfate, and concentrate under reduced pressure.
- Purify the crude product by column chromatography or vacuum distillation.

### Protocol 2: Sommelet Reaction of 4-Chloro-3-methylbenzyl Chloride

- In a round-bottom flask, combine 4-chloro-3-methylbenzyl chloride (1.0 eq.) and hexamine (1.2 eq.) in a 1:1 mixture of chloroform and water.
- Reflux the mixture with vigorous stirring for 2 hours.
- Cool the mixture and separate the aqueous layer.
- Add an equal volume of 50% acetic acid to the aqueous layer and reflux for another 2 hours.

- Cool the reaction mixture and extract the product with diethyl ether.
- Wash the ether extract with water, saturated sodium bicarbonate solution, and brine.
- Dry the organic layer over anhydrous magnesium sulfate and evaporate the solvent.
- Purify the resulting aldehyde by vacuum distillation.

## Visualizations

### Signaling Pathways and Experimental Workflows

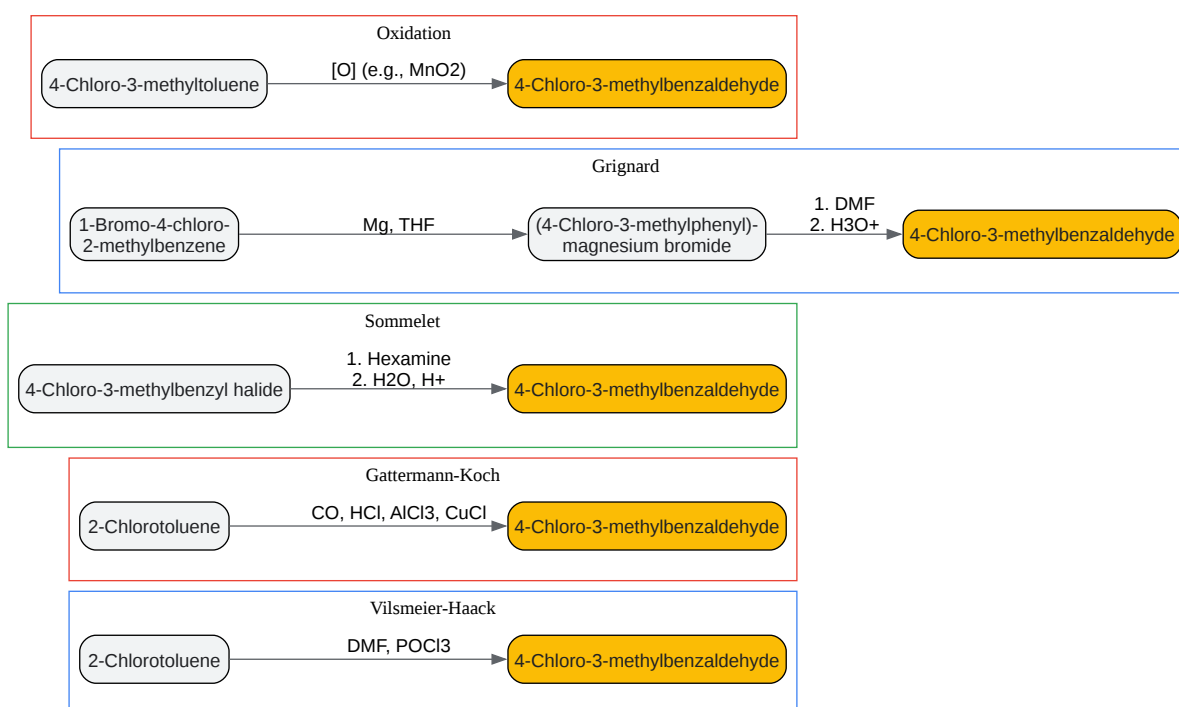

[Click to download full resolution via product page](#)

Caption: Synthetic pathways to **4-Chloro-3-methylbenzaldehyde**.

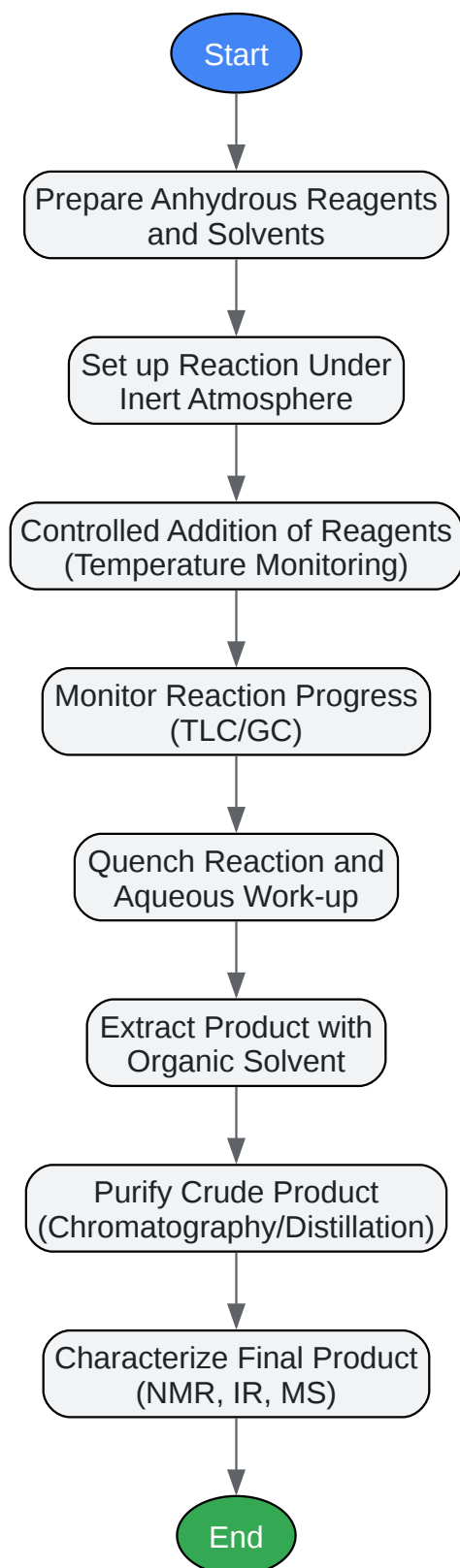

[Click to download full resolution via product page](#)

Caption: General experimental workflow for synthesis.

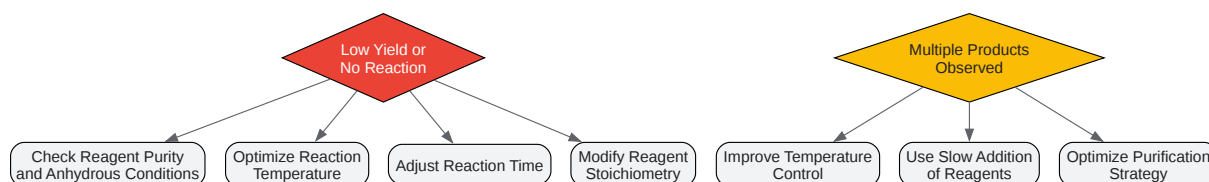

[Click to download full resolution via product page](#)

Caption: Troubleshooting decision tree for low yield.

### Need Custom Synthesis?

BenchChem offers custom synthesis for rare earth carbides and specific isotopic labeling.

Email: [info@benchchem.com](mailto:info@benchchem.com) or [Request Quote Online](#).

## References

- 1. [tfc.com-chemicals-global-nginx.commerceprod.apac.thermofisher.com](https://tfc.com-chemicals-global-nginx.commerceprod.apac.thermofisher.com) [tfc.com-chemicals-global-nginx.commerceprod.apac.thermofisher.com]
- 2. [Gattermann reaction - Wikipedia](https://en.wikipedia.org/wiki/Gattermann_reaction) [en.wikipedia.org]
- 3. [Sommelet Reaction \(Chapter 105\) - Name Reactions in Organic Synthesis](https://resolve.cambridge.org) [resolve.cambridge.org]
- 4. [benchchem.com](https://benchchem.com) [benchchem.com]
- 5. [Sommelet reaction - Wikipedia](https://en.wikipedia.org/wiki/Sommelet_reaction) [en.wikipedia.org]
- 6. [collegedunia.com](https://collegedunia.com) [collegedunia.com]
- 7. [byjus.com](https://byjus.com) [byjus.com]
- 8. [gropedia.com](https://gropedia.com) [gropedia.com]
- To cite this document: BenchChem. [Technical Support Center: Synthesis of 4-Chloro-3-methylbenzaldehyde]. BenchChem, [2026]. [Online PDF]. Available at:

[<https://www.benchchem.com/product/b052831/docs#technical-support-center-synthesis-of-4-chloro-3-methylbenzaldehyde>]

### Disclaimer & Data Validity:

The information provided in this document is for Research Use Only (RUO) and is strictly not intended for diagnostic or therapeutic procedures. While BenchChem strives to provide accurate protocols, we make no warranties, express or implied, regarding the fitness of this product for every specific experimental setup.

**Technical Support:** The protocols provided are for reference purposes. Unsure if this reagent suits your experiment?

**Need Industrial/Bulk Grade?** [Request Custom Synthesis Quote](#)

## BenchChem

Our mission is to be the trusted global source of essential and advanced chemicals, empowering scientists and researchers to drive progress in science and industry.

### Contact

Address: 3281 E Guasti Rd  
Ontario, CA 91761, United States  
Phone: (601) 213-4426  
Email: [info@benchchem.com](mailto:info@benchchem.com)

[Contact our Ph.D. Support Team for a compatibility check](#)