

# Foreword: Unveiling the Blueprint of a Modified Amino Acid

**Author:** BenchChem Technical Support Team. **Date:** May 2026

## Compound of Interest

Compound Name: *D-Lysine, 5-fluoro-*

CAS No.: 118101-17-0

Cat. No.: B052445

[Get Quote](#)

In the landscape of drug discovery and chemical biology, unnatural amino acids serve as powerful tools to probe and modulate biological systems. 5-fluoro-D-lysine, a halogenated variant of a fundamental biological building block, presents a unique set of properties conferred by the strategic placement of a highly electronegative fluorine atom. Understanding its precise three-dimensional structure is not merely an academic exercise; it is the foundational step for predicting its interactions, understanding its metabolic fate, and rationally designing novel peptides or therapeutic agents.[1][2] This guide provides a comprehensive, multi-technique approach to the structural elucidation of 5-fluoro-D-lysine, grounded in the principles of analytical chemistry and biophysics. We will explore not just the "how" but the "why" behind each analytical choice, offering a framework for rigorous and self-validating structural analysis.

## Core Physicochemical Characteristics

Before embarking on advanced structural analysis, a fundamental understanding of the molecule's basic properties is essential. The introduction of a fluorine atom at the 5-position of the D-lysine side chain significantly alters its electronic properties compared to its natural counterpart. This modification can influence the pKa of the side-chain amine, potentially

affecting its role in hydrogen bonding and electrostatic interactions within a peptide or protein.

[3]

Property	Value	Source
Molecular Formula	C <sub>6</sub> H <sub>13</sub> FN <sub>2</sub> O <sub>2</sub>	[4]
Molecular Weight	164.18 g/mol	[5]
Stereochemistry	D-configuration at α-carbon	N/A
Key Feature	Fluorine at the 5-position	N/A
Known Activity	Inhibitor of Escherichia coli growth	[6]

## Nuclear Magnetic Resonance (NMR) Spectroscopy: Probing the Electronic Environment

Expertise & Rationale: NMR spectroscopy is arguably the most powerful technique for elucidating the structure of small molecules in solution. For 5-fluoro-D-lysine, it offers a multi-faceted view. <sup>1</sup>H and <sup>13</sup>C NMR provide a map of the carbon-hydrogen framework, while <sup>19</sup>F NMR offers an exquisitely sensitive probe into the local environment of the fluorine atom.[7][8] The chemical shift of the <sup>19</sup>F nucleus is highly responsive to subtle changes in conformation, solvent exposure, and non-covalent interactions, making it an invaluable tool.[8]

### Workflow for NMR Analysis

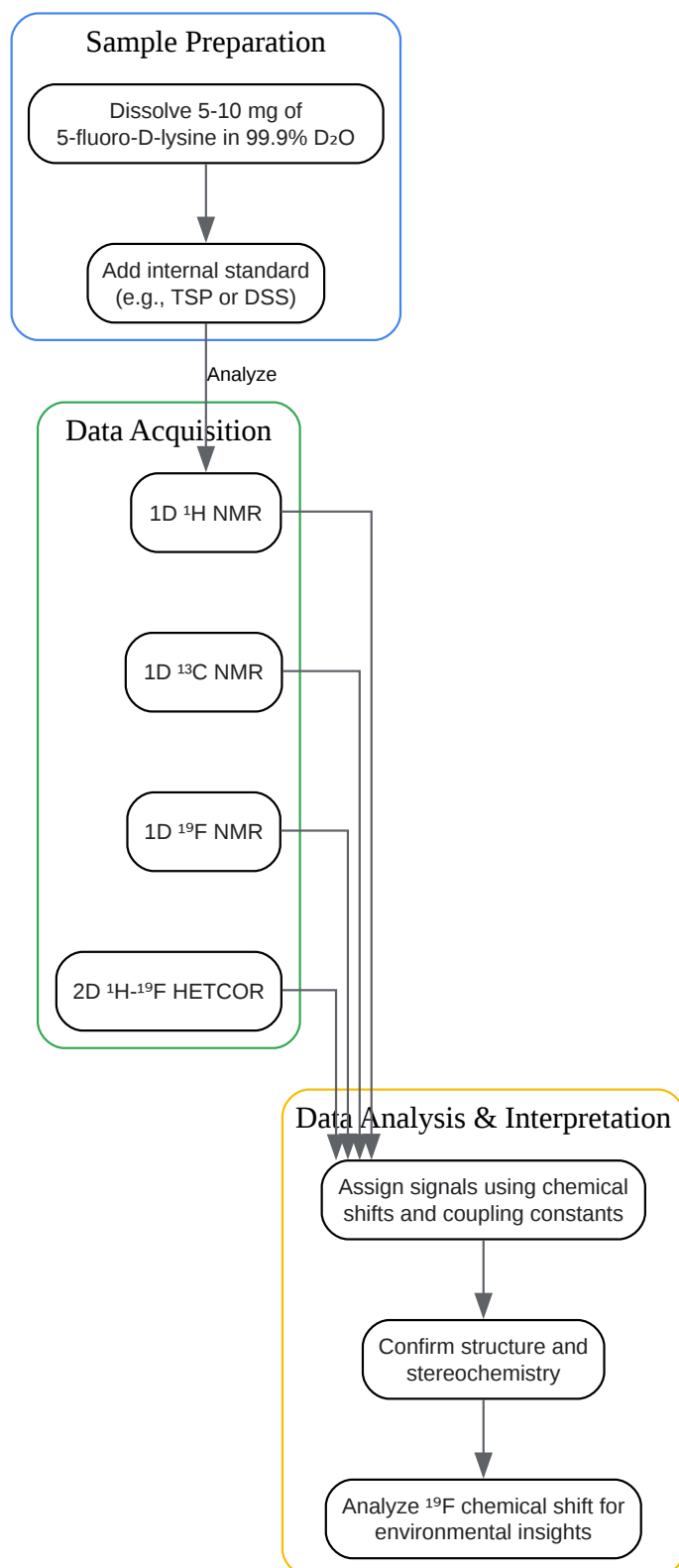

[Click to download full resolution via product page](#)

Fig. 1: Experimental workflow for NMR analysis.

## Detailed Experimental Protocol

- Sample Preparation:
  - Accurately weigh 5-10 mg of 5-fluoro-D-lysine hydrochloride.
  - Dissolve the sample in 0.6 mL of Deuterium Oxide (D<sub>2</sub>O, 99.9% atom D).
  - Add a small quantity of an internal reference standard such as TSP (3-(trimethylsilyl)propionic-2,2,3,3-d<sub>4</sub> acid, sodium salt) for <sup>1</sup>H NMR chemical shift calibration ( $\delta = 0.00$  ppm). For <sup>19</sup>F NMR, an external standard like trifluoroacetic acid (TFA) can be used.
  - Transfer the solution to a 5 mm NMR tube.
- Instrumentation and Data Acquisition:
  - Utilize a high-field NMR spectrometer (e.g., 400 MHz or higher) equipped with a multinuclear probe capable of detecting <sup>1</sup>H, <sup>13</sup>C, and <sup>19</sup>F.
  - <sup>1</sup>H NMR: Acquire a standard one-dimensional proton spectrum. Key parameters include a 30° pulse angle, a relaxation delay of 2 seconds, and 16-32 scans for good signal-to-noise.
  - <sup>19</sup>F NMR: Acquire a one-dimensional fluorine spectrum. This may require proton decoupling to simplify the spectrum to a single resonance (if coupling information is not immediately needed).[7]
  - <sup>13</sup>C NMR: Acquire a proton-decoupled carbon spectrum. Due to the lower natural abundance of <sup>13</sup>C, a larger number of scans (e.g., 1024 or more) and a longer relaxation delay may be necessary.
  - 2D HETCOR (<sup>1</sup>H-<sup>19</sup>F): Acquire a Heteronuclear Correlation spectrum to unambiguously identify which protons are spatially close to the fluorine atom. This is crucial for assigning the proton signals of the lysine side chain.[9]

## Anticipated Results and Interpretation

The power of this protocol lies in its self-validating nature. The  $^1\text{H}$  spectrum will show characteristic multiplets for the protons on the lysine backbone and side chain. The key diagnostic signals will be the protons on C4, C5, and C6, which will be split by the fluorine atom (J-coupling). The  $^{19}\text{F}$  NMR will show a complex multiplet due to coupling with these nearby protons. The 2D  $^1\text{H}$ - $^{19}\text{F}$  HETCOR experiment will directly correlate the  $^{19}\text{F}$  signal with the signals of the protons on C5 and C4, confirming their assignment.

Nucleus	Expected Chemical Shift ( $\delta$ ) Range (ppm)	Key Coupling Constants (J)
$^1\text{H}$ (H-5)	4.0 - 4.8	Large geminal coupling to F (~45-50 Hz, $^2\text{JHF}$ )
$^1\text{H}$ (H-4, H-6)	1.5 - 2.5	Vicinal coupling to F (~15-25 Hz, $^3\text{JHF}$ )
$^{19}\text{F}$	-200 to -230 (relative to $\text{CFCl}_3$ )	Coupled to H-5, H-4, and H-6
$^{13}\text{C}$ (C-5)	88 - 95	Large direct coupling to F (~160-180 Hz, $^1\text{JCF}$ )
$^{13}\text{C}$ (C-4, C-6)	25 - 35	Smaller coupling to F (~15-25 Hz, $^2\text{JCF}$ )

## Mass Spectrometry (MS): Confirming Identity and Fragmentation

**Expertise & Rationale:** Mass spectrometry is the definitive technique for confirming the molecular weight and elemental formula of a compound. High-Resolution Mass Spectrometry (HRMS), particularly with techniques like Electrospray Ionization (ESI), provides a mass measurement with high accuracy (typically < 5 ppm error), allowing for unambiguous determination of the elemental composition. Furthermore, tandem mass spectrometry (MS/MS) allows us to isolate the molecular ion and fragment it in a controlled manner, providing a "fingerprint" that is characteristic of the molecule's structure.

## Workflow for Mass Spectrometry

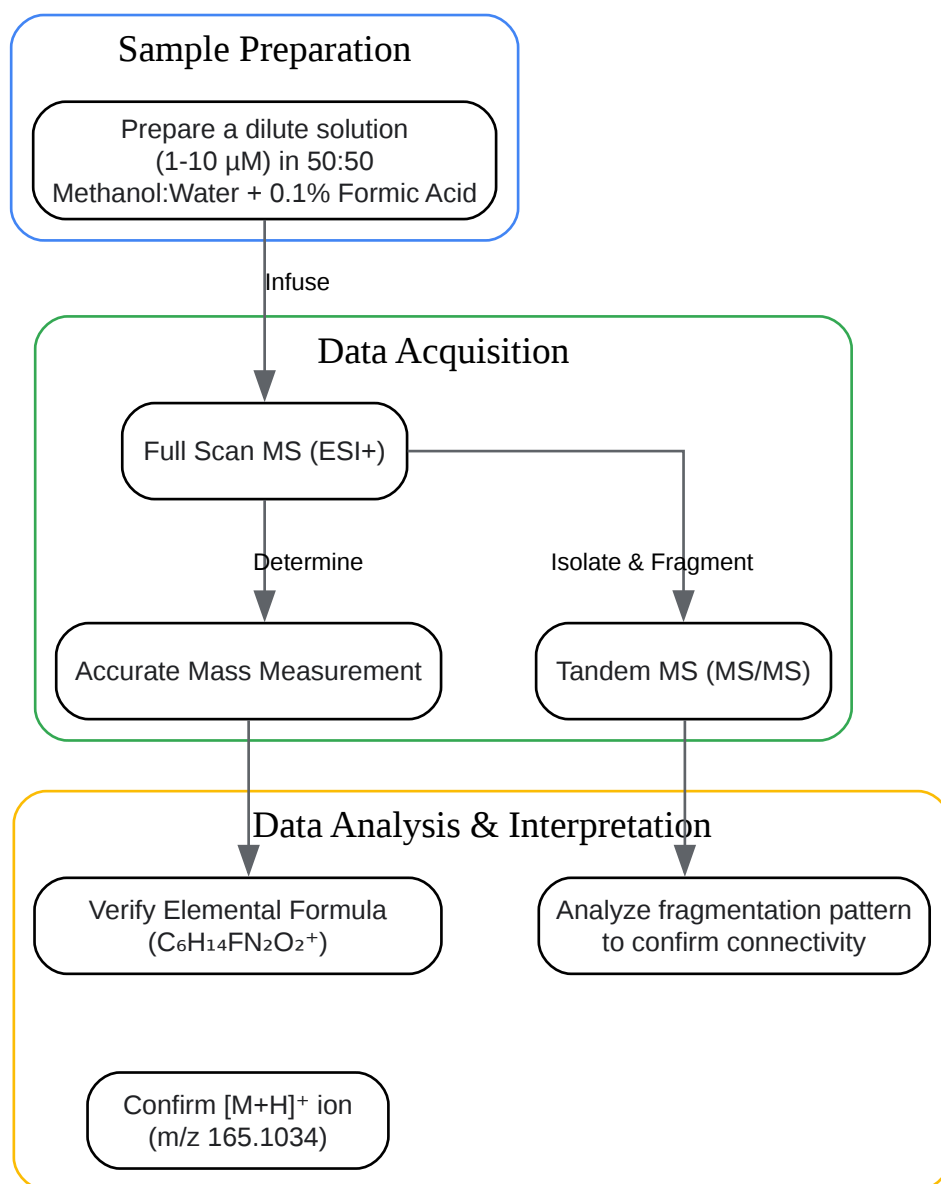

[Click to download full resolution via product page](#)

Fig. 2: Workflow for Mass Spectrometry analysis.

## Detailed Experimental Protocol

- Sample Preparation:
  - Prepare a stock solution of 5-fluoro-D-lysine in water or methanol.
  - Dilute the stock solution to a final concentration of 1-10 μM in a suitable solvent for ESI, typically 50:50 methanol/water or acetonitrile/water with 0.1% formic acid to promote

protonation.

- Instrumentation and Data Acquisition:
  - Utilize an HRMS instrument such as a Quadrupole Time-of-Flight (Q-TOF) or Orbitrap mass spectrometer.
  - Full Scan MS: Acquire a full scan spectrum in positive ion mode (ESI+). The expected protonated molecular ion  $[M+H]^+$  should be observed at  $m/z$  165.1034.
  - Tandem MS (MS/MS): Perform a product ion scan. Set the instrument to isolate the  $[M+H]^+$  ion ( $m/z$  165.1) in the first stage of the mass spectrometer (e.g., the quadrupole). Induce fragmentation using collision-induced dissociation (CID) with argon or nitrogen gas. Scan the resulting fragment ions in the second stage (e.g., the TOF or Orbitrap).

## Anticipated Results and Fragmentation Pathway

The full scan HRMS will confirm the elemental formula  $C_6H_{13}FN_2O_2$ . Unlike compounds containing chlorine or bromine, which have distinct isotopic patterns (M+2 peaks), fluorine is monoisotopic, so no such pattern will be observed.<sup>[10][11]</sup>

The MS/MS spectrum provides the structural fingerprint. The fragmentation is predictable and validates the known structure. Key fragmentation pathways for amino acids include the loss of water ( $H_2O$ ) and the loss of the carboxyl group (as  $COOH_2$  or  $CO + H_2O$ ). For 5-fluoro-D-lysine, characteristic losses involving the fluorine atom are also expected.

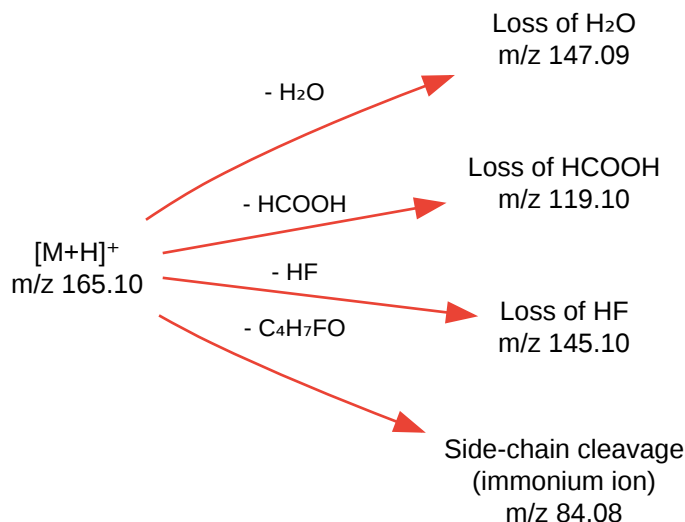

[Click to download full resolution via product page](#)

*Fig. 3: Predicted MS/MS fragmentation of 5-fluoro-D-lysine.*

## X-ray Crystallography: The Definitive 3D Structure

Expertise & Rationale: While NMR provides the structure in solution and MS confirms identity, X-ray crystallography yields the precise three-dimensional arrangement of atoms in the solid state. It is the gold standard for determining bond lengths, bond angles, and, crucially, the absolute stereochemistry of chiral centers. For 5-fluoro-D-lysine, this technique can definitively confirm the D-configuration at the  $\alpha$ -carbon and reveal the preferred conformation of the fluorinated side chain in the crystal lattice.[\[12\]](#)[\[13\]](#)

## Workflow for X-ray Crystallography

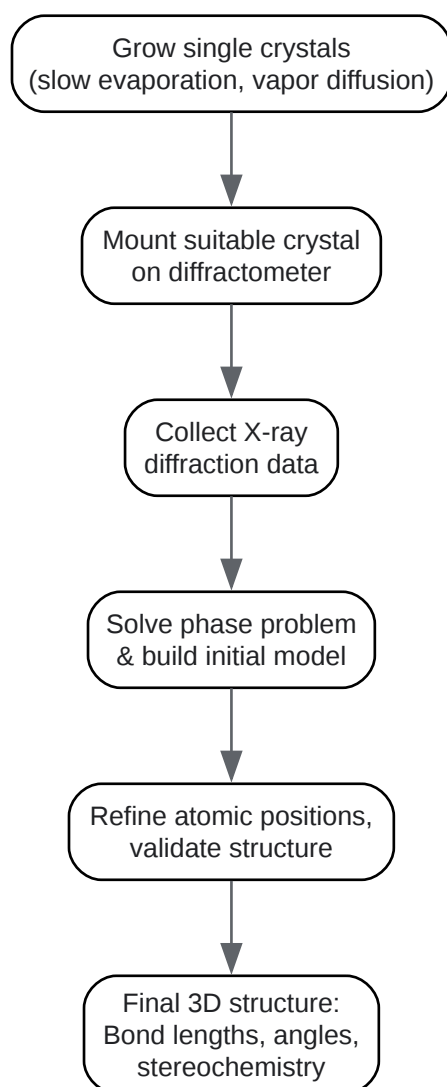

[Click to download full resolution via product page](#)

*Fig. 4: General workflow for single-crystal X-ray crystallography.*

## Detailed Experimental Protocol

- Crystallization (The Critical Step):
  - This is an empirical process. Screen a variety of conditions. A common starting point is to create a saturated solution of 5-fluoro-D-lysine hydrochloride in a solvent or solvent mixture (e.g., water/ethanol, water/isopropanol).
  - Slow Evaporation: Leave the solution in a loosely covered vial to allow the solvent to evaporate slowly over days or weeks.

- Vapor Diffusion: Place a drop of the concentrated sample solution on a coverslip and invert it over a well containing a solvent in which the compound is less soluble (the precipitant). The slow diffusion of the precipitant vapor into the drop can induce crystallization.
- Data Collection:
  - Identify a high-quality single crystal under a microscope (clear, well-defined faces, no visible cracks).
  - Mount the crystal on a goniometer head and place it in the cold stream (typically 100 K) of an X-ray diffractometer.
  - Collect a full sphere of diffraction data by rotating the crystal in the X-ray beam.
- Structure Solution and Refinement:
  - Process the diffraction data to obtain a list of reflection intensities.
  - Use specialized software (e.g., SHELX, Olex2) to solve the structure, typically using direct methods or Patterson methods to determine the initial positions of the atoms.
  - Refine the model against the experimental data, adjusting atomic positions and thermal parameters to achieve the best fit. This process will yield the final, high-resolution 3D structure.

## Anticipated Results and Interpretation

The final output is a detailed atomic model. This allows for the precise measurement of all bond lengths and angles. Of particular interest will be the C-F bond length (~1.35-1.40 Å) and the effect of the fluorine substitution on the geometry of the side chain. The analysis will also reveal the crystal packing, showing how individual molecules interact with each other through hydrogen bonds and other intermolecular forces. Most importantly, the analysis can determine the absolute configuration, confirming the 'D' stereochemistry at the C $\alpha$  position.<sup>[14]</sup>

## Computational Modeling: An In Silico Complement

Expertise & Rationale: Computational chemistry provides a powerful complement to experimental data.[15][16] By building an in silico model of 5-fluoro-D-lysine, we can predict its lowest energy conformation, visualize its electrostatic potential surface, and even calculate theoretical NMR chemical shifts to compare with experimental results. This synergy between theory and experiment provides a deeper level of confidence in the final structural assignment.

## Workflow for Computational Modeling

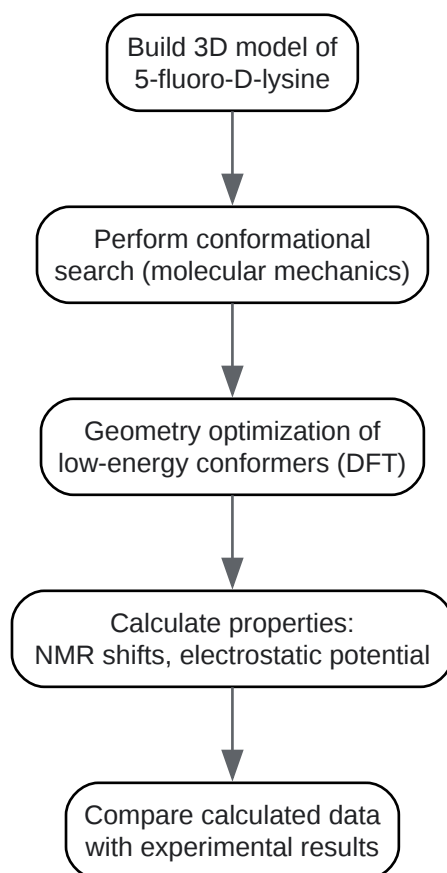

[Click to download full resolution via product page](#)

### Need Custom Synthesis?

BenchChem offers custom synthesis for rare earth carbides and specific isotopic labeling.

Email: [info@benchchem.com](mailto:info@benchchem.com) or [Request Quote Online](#).

## Sources

- [1. Effects of D-Lysine Substitutions on the Activity and Selectivity of Antimicrobial Peptide CM15 - PubMed \[pubmed.ncbi.nlm.nih.gov\]](#)
- [2. Effects of D-Lysine Substitutions on the Activity and Selectivity of Antimicrobial Peptide CM15 - PMC \[pmc.ncbi.nlm.nih.gov\]](#)
- [3. par.nsf.gov \[par.nsf.gov\]](#)
- [4. 5-Fluoro-D,L-lysine Hydrochloride \(90%\) | CymitQuimica \[cymitquimica.com\]](#)
- [5. 4-Fluoro-L-lysine | C6H13FN2O2 | CID 22825317 - PubChem \[pubchem.ncbi.nlm.nih.gov\]](#)
- [6. scbt.com \[scbt.com\]](#)
- [7. kops.uni-konstanz.de \[kops.uni-konstanz.de\]](#)
- [8. biophysics.org \[biophysics.org\]](#)
- [9. 19F-NMR spectroscopy of fluorinated isoleucine analogues in a protein - PMC \[pmc.ncbi.nlm.nih.gov\]](#)
- [10. chem.libretexts.org \[chem.libretexts.org\]](#)
- [11. Mass Spectrometry | Organic Chemistry I Lab \[blog.richmond.edu\]](#)
- [12. ias.ac.in \[ias.ac.in\]](#)
- [13. Chemical synthesis and X-ray structure of a heterochiral {D-protein antagonist plus vascular endothelial growth factor} protein complex by racemic crystallography - PMC \[pmc.ncbi.nlm.nih.gov\]](#)
- [14. The x-ray structure of D-amino acid oxidase at very high resolution identifies the chemical mechanism of flavin-dependent substrate dehydrogenation - PubMed \[pubmed.ncbi.nlm.nih.gov\]](#)
- [15. Topological analysis and predictive modeling of amino acid structures with implications for bioinformatics and structural biology - PMC \[pmc.ncbi.nlm.nih.gov\]](#)
- [16. mdpi.com \[mdpi.com\]](#)
- [To cite this document: BenchChem. \[Foreword: Unveiling the Blueprint of a Modified Amino Acid\]. BenchChem, \[2026\]. \[Online PDF\]. Available at: \[https://www.benchchem.com/product/b052445/docs#foreword-unveiling-the-blueprint-of-a-modified-amino-acid\]](#)

---

### Disclaimer & Data Validity:

The information provided in this document is for Research Use Only (RUO) and is strictly not intended for diagnostic or therapeutic procedures. While BenchChem strives to provide

accurate protocols, we make no warranties, express or implied, regarding the fitness of this product for every specific experimental setup.

**Technical Support:** The protocols provided are for reference purposes. Unsure if this reagent suits your experiment?

**Need Industrial/Bulk Grade?** [Request Custom Synthesis Quote](#)

## BenchChem

Our mission is to be the trusted global source of essential and advanced chemicals, empowering scientists and researchers to drive progress in science and industry.

### Contact

Address: 3281 E Guasti Rd

Ontario, CA 91761, United States

Phone: (601) 213-4426

Email: [info@benchchem.com](mailto:info@benchchem.com)

[Contact our Ph.D. Support Team for a compatibility check](#)