

# A Comparative Analysis: Urea-Based Kinase Inhibitors Versus First-Generation Counterparts

**Author:** BenchChem Technical Support Team. **Date:** April 2026

## Compound of Interest

Compound Name: *1-Carbamoyl-3-(4-methoxyphenyl)urea*

CAS No.: *14032-35-0*

Cat. No.: *B5141596*

[Get Quote](#)

For researchers, scientists, and drug development professionals, this guide provides an objective comparison of the performance of urea-based kinase inhibitors against first-generation inhibitors, supported by experimental data. The focus is on inhibitors targeting key signaling pathways implicated in cancer: Vascular Endothelial Growth Factor Receptor (VEGFR), Epidermal Growth Factor Receptor (EGFR), and Bcr-Abl.

While the specific compound **1-Carbamoyl-3-(4-methoxyphenyl)urea** acts as a versatile scaffold in medicinal chemistry, this guide will focus on well-characterized, urea-containing drugs, such as Sorafenib and Regorafenib, and compare their efficacy with established first-generation tyrosine kinase inhibitors (TKIs).

## Executive Summary

Urea-based kinase inhibitors have emerged as a significant class of therapeutics, often exhibiting multi-kinase inhibitory activity. This contrasts with many first-generation inhibitors that were developed with a primary target in mind. This guide will delve into the quantitative differences in inhibitory potency (IC50 values) and provide an overview of the experimental

methodologies used to determine these values. Furthermore, it will visualize the targeted signaling pathways to provide a comprehensive understanding of their mechanisms of action.

## Data Presentation: Quantitative Comparison of Inhibitory Potency

The following tables summarize the half-maximal inhibitory concentrations (IC50) of representative urea-based and first-generation inhibitors against their respective kinase targets. Lower IC50 values indicate greater potency.

Table 1: Comparison of VEGFR Inhibitors

Inhibitor Class	Compound	VEGFR1 IC50 (nM)	VEGFR2 IC50 (nM)	VEGFR3 IC50 (nM)	Other Key Targets (IC50 nM)
Urea-Based	Sorafenib	26	90[1][2]	20[1][2]	B-Raf (22), Raf-1 (6)[1][2], c-KIT (68)[1], PDGFR-β (57)[1][2]
Urea-Based	Regorafenib	13[1][3]	4.2[1][3]	46[1][3]	PDGFRβ (22), c-Kit (7), RET (1.5), Raf-1 (2.5)[1][3]
First-Generation	Sunitinib	10[4]	80[1][5]	10[4]	PDGFRβ (2)[1][5][6][7], c-Kit
First-Generation	Axitinib	0.1[8]	0.2[8]	0.1-0.3[8]	PDGFRβ (1.6), c-Kit (1.7)[8]
First-Generation	Pazopanib	10[9][10]	30[9][10]	47[9][10]	PDGFR (84), c-Kit (74)[9][10]

Table 2: Comparison of EGFR Inhibitors

Inhibitor Class	Compound	EGFR (wild-type) IC50 (nM)	EGFR (mutant) IC50 (nM)
First-Generation	Gefitinib	33	L858R: ~37[11][12]; Exon 19 Del: ~37[11] [12]
First-Generation	Erlotinib	2[13][14]	L858R: ~20; Exon 19 Del: ~20[15]

Note: Specific urea-based inhibitors with primary EGFR inhibitory action are less common than multi-kinase inhibitors where EGFR is a secondary target. Therefore, a direct comparison table is not provided for this class.

Table 3: Comparison of Bcr-Abl Inhibitors

Inhibitor Class	Compound	Bcr-Abl IC50 (nM)
First-Generation	Imatinib	~100-500

Note: While some urea-based compounds have been investigated as Bcr-Abl inhibitors, there are no widely approved drugs in this class with this primary mechanism of action for direct comparison with the first-generation standard, Imatinib.

## Experimental Protocols

The data presented in the tables above are derived from various in vitro assays. Below are detailed methodologies for the key experiments cited.

### In Vitro Kinase Assay

This assay directly measures the ability of a compound to inhibit the enzymatic activity of a purified kinase.

- Reagents and Materials: Purified recombinant kinase, kinase-specific substrate (peptide or protein), ATP (often radiolabeled with  $^{32}\text{P}$  or  $^{33}\text{P}$ ), kinase assay buffer (containing  $\text{MgCl}_2$ ), test compounds (inhibitors), and a method for detecting substrate phosphorylation.
- Procedure:
  1. The kinase, substrate, and test compound are pre-incubated in the kinase assay buffer in a multi-well plate.
  2. The kinase reaction is initiated by the addition of ATP.
  3. The reaction is allowed to proceed for a defined period at a specific temperature (e.g.,  $30^\circ\text{C}$ ).
  4. The reaction is terminated, often by the addition of a stop solution containing EDTA, which chelates the  $\text{Mg}^{2+}$  ions necessary for kinase activity.
  5. The amount of phosphorylated substrate is quantified. If radiolabeled ATP is used, this can be done by separating the phosphorylated substrate from the unreacted ATP (e.g., using phosphocellulose paper) and measuring the incorporated radioactivity with a scintillation counter. Alternatively, non-radioactive methods may employ phospho-specific antibodies in an ELISA or fluorescence-based detection format.
  6.  $\text{IC}_{50}$  values are calculated by plotting the percentage of kinase inhibition against a range of inhibitor concentrations.

## Cell Viability Assay (MTT Assay)

This assay assesses the effect of an inhibitor on the metabolic activity of cancer cell lines, which is an indicator of cell viability and proliferation.

- Reagents and Materials: Cancer cell lines expressing the target kinase, cell culture medium, 96-well plates, test compounds, MTT (3-(4,5-dimethylthiazol-2-yl)-2,5-diphenyltetrazolium bromide) solution, and a solubilizing agent (e.g., DMSO or an acidic SDS solution).[1][16]
- Procedure:
  1. Cells are seeded into 96-well plates and allowed to adhere overnight.

2. The cells are then treated with various concentrations of the test compound and incubated for a specified period (e.g., 72 hours).[17]
3. Following incubation, the culture medium is removed, and MTT solution is added to each well.[18]
4. The plates are incubated for a few hours (e.g., 4 hours) at 37°C, during which viable cells with active mitochondrial dehydrogenases reduce the yellow MTT to purple formazan crystals.[16][19]
5. The MTT solution is removed, and a solubilizing agent is added to dissolve the formazan crystals, resulting in a colored solution.[18]
6. The absorbance of the solution is measured using a microplate reader at a wavelength of approximately 570 nm.
7. The absorbance is directly proportional to the number of viable cells. IC50 values are determined by plotting cell viability against the inhibitor concentration.

## Western Blot Analysis

This technique is used to detect changes in protein expression and phosphorylation status within cells following treatment with an inhibitor, confirming the inhibitor's effect on its target and downstream signaling pathways.

- Reagents and Materials: Cancer cell lines, cell lysis buffer, SDS-PAGE gels, transfer apparatus, nitrocellulose or PVDF membranes, blocking buffer (e.g., non-fat milk or BSA in TBST), primary antibodies (specific for the target kinase, its phosphorylated form, and downstream signaling proteins), HRP-conjugated secondary antibodies, and a chemiluminescent substrate.
- Procedure:
  1. Cells are treated with the inhibitor for a specified time.
  2. The cells are then lysed to extract total cellular proteins.

3. Protein concentration is determined, and equal amounts of protein from each sample are separated by size using SDS-PAGE.
4. The separated proteins are transferred from the gel to a membrane.
5. The membrane is blocked to prevent non-specific antibody binding.
6. The membrane is incubated with a primary antibody that specifically binds to the protein of interest (e.g., phospho-VEGFR2).
7. After washing, the membrane is incubated with an HRP-conjugated secondary antibody that binds to the primary antibody.
8. The membrane is treated with a chemiluminescent substrate, and the resulting light signal, which corresponds to the amount of the target protein, is detected using an imaging system.
9. The membrane can be stripped and re-probed with other antibodies (e.g., for total VEGFR2 or a loading control like actin) to confirm equal protein loading and to assess the specific inhibition of phosphorylation.

## Signaling Pathway and Experimental Workflow Diagrams

The following diagrams, generated using the DOT language for Graphviz, illustrate key signaling pathways and a typical experimental workflow for inhibitor evaluation.

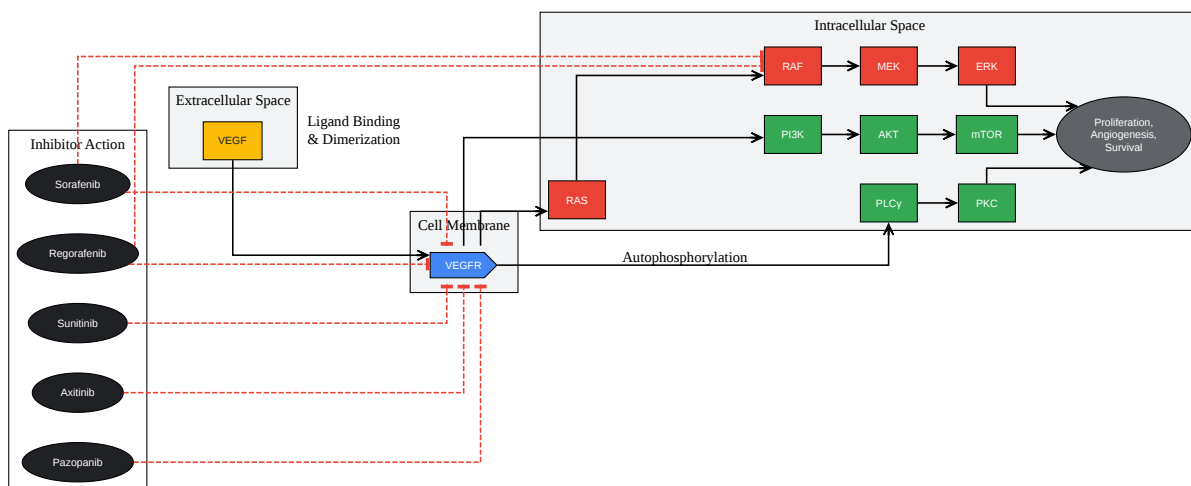

[Click to download full resolution via product page](#)

Caption: VEGFR Signaling Pathway and Inhibitor Targets.

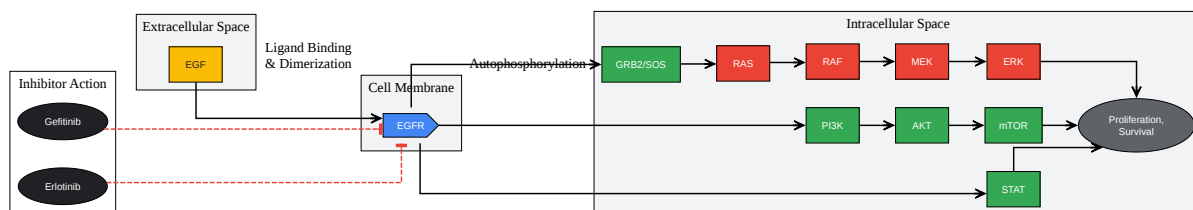

[Click to download full resolution via product page](#)

Caption: EGFR Signaling Pathway and First-Generation Inhibitor Targets.

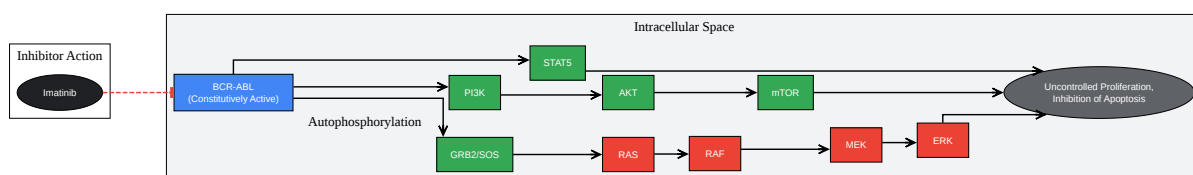

[Click to download full resolution via product page](#)

Caption: Bcr-Abl Signaling Pathway and Imatinib's Target.

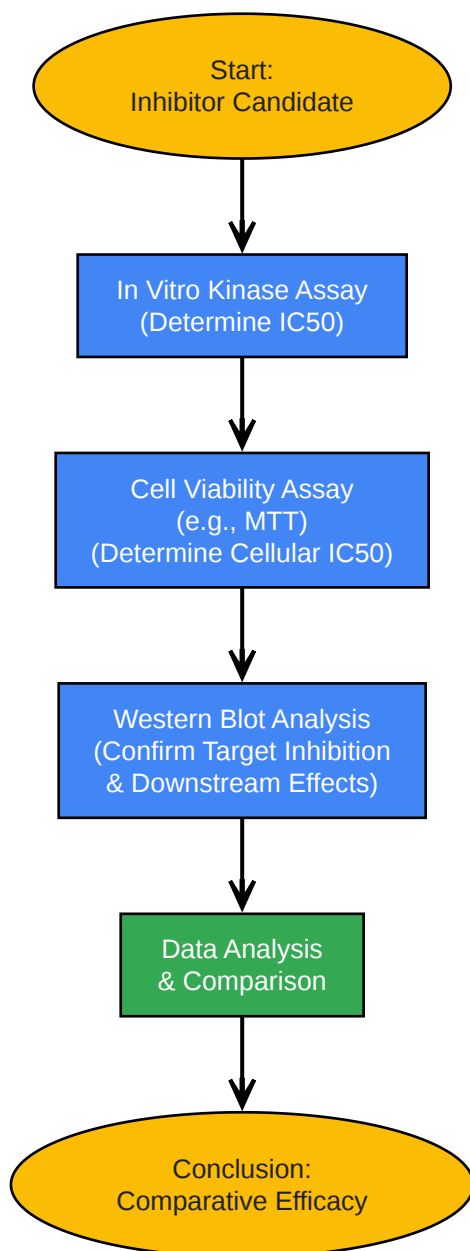

[Click to download full resolution via product page](#)

Caption: General Experimental Workflow for Inhibitor Evaluation.

## Conclusion

This comparative guide highlights that urea-based kinase inhibitors, exemplified by Sorafenib and Regorafenib, often present as multi-targeted agents with potent activity against VEGFR and other kinases involved in tumor progression. In contrast, first-generation inhibitors like Sunitinib, Axitinib, Pazopanib, Gefitinib, and Erlotinib were generally developed with a more

selective target profile. The choice between a multi-targeted urea-based inhibitor and a more selective first-generation inhibitor depends on the specific therapeutic strategy, the genetic makeup of the tumor, and the desired balance between efficacy and potential off-target effects. The provided experimental protocols and pathway diagrams offer a foundational understanding for researchers to design and interpret studies in the ongoing development of novel kinase inhibitors.

### Need Custom Synthesis?

*BenchChem offers custom synthesis for rare earth carbides and specific isotopic labeling.*

*Email: [info@benchchem.com](mailto:info@benchchem.com) or [Request Quote Online](#).*

## References

- [1. selleckchem.com](https://www.selleckchem.com) [selleckchem.com]
- [2. selleckchem.com](https://www.selleckchem.com) [selleckchem.com]
- [3. selleckchem.com](https://www.selleckchem.com) [selleckchem.com]
- [4. Vorolanib, sunitinib, and axitinib: A comparative study of vascular endothelial growth factor receptor inhibitors and their anti-angiogenic effects - PMC](#) [pmc.ncbi.nlm.nih.gov]
- [5. selleckchem.com](https://www.selleckchem.com) [selleckchem.com]
- [6. medchemexpress.com](https://www.medchemexpress.com) [medchemexpress.com]
- [7. selleckchem.com](https://www.selleckchem.com) [selleckchem.com]
- [8. selleckchem.com](https://www.selleckchem.com) [selleckchem.com]
- [9. Pazopanib | Cell Signaling Technology](https://www.cellsignal.com) [cellsignal.com]
- [10. selleckchem.com](https://www.selleckchem.com) [selleckchem.com]
- [11. selleckchem.com](https://www.selleckchem.com) [selleckchem.com]
- [12. selleckchem.com](https://www.selleckchem.com) [selleckchem.com]
- [13. selleckchem.com](https://www.selleckchem.com) [selleckchem.com]
- [14. medchemexpress.com](https://www.medchemexpress.com) [medchemexpress.com]
- [15. aacrjournals.org](https://aacrjournals.org) [aacrjournals.org]
- [16. MTT Assay Protocol for Cell Viability and Proliferation](https://www.merckmillipore.com) [merckmillipore.com]

- [17. Reduced erlotinib sensitivity of EGFR mutant non-small cell lung cancer following cisplatin exposure: A cell culture model of second-line erlotinib treatment - PMC \[pmc.ncbi.nlm.nih.gov\]](#)
- [18. MTT \(Assay protocol \[protocols.io\]\)](#)
- [19. texaschildrens.org \[texaschildrens.org\]](#)
- To cite this document: BenchChem. [A Comparative Analysis: Urea-Based Kinase Inhibitors Versus First-Generation Counterparts]. BenchChem, [2026]. [Online PDF]. Available at: [\[https://www.benchchem.com/product/b5141596/docs#a-comparative-analysis-urea-based-kinase-inhibitors-versus-first-generation-counterparts\]](https://www.benchchem.com/product/b5141596/docs#a-comparative-analysis-urea-based-kinase-inhibitors-versus-first-generation-counterparts)

---

### Disclaimer & Data Validity:

The information provided in this document is for Research Use Only (RUO) and is strictly not intended for diagnostic or therapeutic procedures. While BenchChem strives to provide accurate protocols, we make no warranties, express or implied, regarding the fitness of this product for every specific experimental setup.

**Technical Support:** The protocols provided are for reference purposes. Unsure if this reagent suits your experiment?

**Need Industrial/Bulk Grade?** [Request Custom Synthesis Quote](#)

## BenchChem

Our mission is to be the trusted global source of essential and advanced chemicals, empowering scientists and researchers to drive progress in science and industry.

### Contact

Address: 3281 E Guasti Rd  
Ontario, CA 91761, United States  
Phone: (601) 213-4426  
Email: [info@benchchem.com](mailto:info@benchchem.com)

Contact our Ph.D. Support Team for a compatibility check