

Minimizing by-product formation in reactions involving BHT.

Author: BenchChem Technical Support Team. **Date:** December 2025

Compound of Interest

Compound Name: 2,6-Di-tert-butyl-4-methylphenol

Cat. No.: B512018

[Get Quote](#)

Technical Support Center: Reactions Involving BHT

This technical support center provides troubleshooting guidance and frequently asked questions (FAQs) for researchers, scientists, and drug development professionals working with butylated hydroxytoluene (BHT). The information provided aims to help minimize the formation of unwanted by-products in your experiments.

Frequently Asked Questions (FAQs)

Q1: What is the primary function of BHT in a reaction?

A1: Butylated hydroxytoluene (BHT) is a synthetic phenolic antioxidant used to prevent the oxidation of organic materials.[1] It functions as a free-radical scavenger, terminating the chain reactions of autoxidation by donating a hydrogen atom from its hydroxyl group to peroxy radicals.[1] This process converts the peroxy radicals into more stable hydroperoxides, while the BHT itself becomes a resonance-stabilized phenoxyl radical.[2]

Q2: What are the most common by-products observed in reactions with BHT?

A2: The oxidation of BHT can lead to several by-products. The most frequently reported include:

- 2,6-di-tert-butyl-4-hydroperoxyl-4-methyl-2,5-cyclohexadienone (BHTOOH): A peroxide formed from the reaction of BHT with oxygen.[3]
- 2,6-di-tert-butyl-p-benzoquinone (BHT-Q)[4]
- 3,5-di-tert-butyl-4-hydroxybenzaldehyde (BHT-CHO)
- 2,6-di-tert-butyl-4-methylene-2,5-cyclohexadienone (Quinone Methide - QM): A highly reactive electrophilic species.
- Dimerization products: Such as 1,2-bis-(3,5-di-tert-butyl-4-hydroxyphenyl)ethane.

Q3: What factors can influence the rate of BHT degradation and by-product formation?

A3: Several factors can accelerate the degradation of BHT and the formation of by-products:

- Temperature: Higher temperatures generally increase the rate of oxidation. The initial oxidation temperature of BHT in a closed vessel is approximately 159.8°C, but this can be significantly lowered by the presence of acids or bases. BHT is reported to be the least stable among common antioxidants like BHA and TBHQ at frying temperatures.
- Presence of Oxygen: BHT is readily oxidized in an oxygen atmosphere, whereas it remains stable under a nitrogen atmosphere up to 450 K.
- pH (Acids and Bases): The presence of acids (like HCl) and bases (like KOH) can lower the initial oxidation temperature of BHT. For instance, KOH can initiate the oxidation of BHT even at 20°C. The hydrolysis of BHT's quinone methide is also subject to acid/base catalysis.
- UV Radiation: Exposure to UV light can promote BHT oxidation, even at room temperature (293 K).
- Metal Ions: The presence of certain metal ions can potentially influence the stability of BHT.

Q4: Can by-products of BHT be toxic?

A4: Yes, some by-products of BHT can be toxic. For example, BHTOOH has been reported to be a toxic metabolite that can cause DNA damage. The formation of reactive intermediates like quinone methide is also a concern due to their ability to react with biological nucleophiles.

Troubleshooting Guide

This guide addresses common issues encountered during reactions involving BHT.

Problem	Potential Cause(s)	Recommended Solution(s)
Yellowing of the reaction mixture or product.	Formation of colored by-products due to BHT oxidation.	<ul style="list-style-type: none">• Conduct the reaction under an inert atmosphere (e.g., nitrogen or argon) to minimize contact with oxygen.• Protect the reaction from light, especially UV radiation.• Use the minimum effective concentration of BHT.• Consider performing the reaction at a lower temperature.
Low yield of the desired product.	<ul style="list-style-type: none">• BHT by-products may be reacting with your starting materials or product.• The reactive quinone methide intermediate may be forming adducts with nucleophilic species in the reaction mixture.	<ul style="list-style-type: none">• Optimize the reaction temperature to be as low as possible.• Ensure the reaction is performed under an inert atmosphere.• If your product or reagents are nucleophilic, consider using an alternative antioxidant.
Presence of unexpected peaks in analytical results (e.g., HPLC, GC-MS).	Formation of BHT degradation products.	<ul style="list-style-type: none">• Identify the by-products by comparing their mass spectra or retention times with known BHT degradation products such as BHT-Q, BHT-CHO, and BHTOOH.• See the "Experimental Protocols" section for analytical methods.
Reaction fails to go to completion or stalls.	BHT or its by-products might be interfering with a catalyst or a reactive intermediate in your desired reaction pathway.	<ul style="list-style-type: none">• Evaluate the compatibility of BHT with your specific reaction system.• Consider adding BHT after the main reaction is complete if its purpose is for final product stability.• Explore

alternative antioxidants if
incompatibility is confirmed.

Quantitative Data on By-Product Formation

The following table summarizes quantitative data related to BHT oxidation and by-product formation from various studies.

Parameter	Condition	Result	Reference
Initial Oxidation Temperature	High-pressure closed vessel	159.8 °C	
In the presence of HCl	55.2 °C		
In the presence of KOH	67.2 °C		
BHT Conversion	Atmospheric pressure with HCl	< 5%	
Atmospheric pressure with 2% molar ratio of KOH (at 20°C)	Oxidation initiated		
Peroxide Value	BHT oxidized at 358 K (85°C) for 8 hours in a closed vessel	3.2 mmol/kg	
Apparent Activation Energy (Ea) of Oxidation	In a closed vessel with oxygen	101.4 kJ/mol	
Under UV radiation	Significantly reduced compared to thermal oxidation		

Experimental Protocols

Protocol 1: General Precautions to Minimize BHT By-Product Formation

- **Inert Atmosphere:** Before starting the reaction, thoroughly purge the reaction vessel with an inert gas such as nitrogen or argon to remove oxygen. Maintain a positive pressure of the inert gas throughout the experiment.
- **Temperature Control:** Conduct the reaction at the lowest feasible temperature to slow down the rate of BHT oxidation. Use a reliable temperature controller and monitor the internal reaction temperature.
- **Light Protection:** Whenever possible, protect the reaction mixture from light by covering the glassware with aluminum foil or using amber-colored glassware, especially if the reaction is sensitive to UV radiation.
- **pH Consideration:** Be aware that acidic or basic conditions can lower the oxidation temperature of BHT. If possible, maintain a neutral pH unless the reaction chemistry requires acidic or basic conditions.
- **Solvent Purity:** Use high-purity, peroxide-free solvents, as impurities can initiate radical chain reactions.

Protocol 2: Analysis of BHT and its By-products by GC-MS

This protocol is adapted from methodologies described for the analysis of BHT and its degradation products.

- **Sample Preparation:**
 - Dilute a known amount of the reaction mixture in a suitable solvent (e.g., ethyl acetate or acetonitrile).
 - If necessary, perform a liquid-liquid extraction or solid-phase extraction to isolate the analytes and remove interfering substances.
- **Internal Standard:**

- Add a known concentration of an internal standard (e.g., BHT-d21 or 3,5-di-tert-butylphenol) to the sample for accurate quantification.
- GC-MS Conditions:
 - Column: Use a non-polar capillary column, such as one with a 5% phenyl methylpolysiloxane stationary phase (e.g., Rxi-5Sil).
 - Oven Temperature Program: An example program could be: initial temperature of 70°C for 4 minutes, ramp at 10°C/min to 270°C, then ramp at 25°C/min to 290°C and hold for 10 minutes.
 - Carrier Gas: Helium at a constant flow rate (e.g., 1 mL/min).
 - Injection: Use a split or splitless injector, depending on the concentration of the analytes.
 - Mass Spectrometer: Operate in electron ionization (EI) mode. For quantification, use selected ion monitoring (SIM) mode for higher sensitivity and specificity. Key ions for BHT are m/z 205 and 220.
- Quantification:
 - Create a calibration curve using standards of BHT and known by-products at various concentrations.
 - Determine the concentration of BHT and its by-products in the sample by comparing their peak areas to that of the internal standard and using the calibration curve.

Protocol 3: Analysis of BHT and its By-products by HPLC-UV

This protocol is based on established HPLC methods for BHT analysis.

- Sample Preparation:
 - Dissolve the sample in the mobile phase or a compatible solvent.

- Filter the sample through a 0.45 μm syringe filter before injection to remove particulate matter.
- HPLC Conditions:
 - Column: A C18 reversed-phase column is commonly used.
 - Mobile Phase: A gradient elution with a mixture of acetonitrile and water is often effective. A small amount of acid (e.g., sulfuric acid or acetic acid) may be added to improve peak shape.
 - Flow Rate: Typically around 1.0 mL/min.
 - Detection: Use a UV detector set at a wavelength where BHT and its by-products have significant absorbance, such as 280 nm.
- Quantification:
 - Prepare a calibration curve by injecting known concentrations of BHT and by-product standards.
 - Quantify the analytes in the sample by comparing their peak areas to the calibration curve.

Visualizations

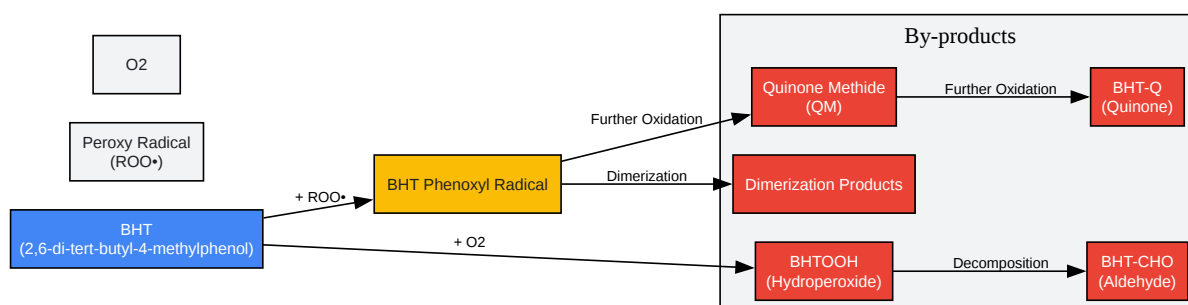

[Click to download full resolution via product page](#)

Caption: Simplified BHT oxidation pathway leading to by-products.

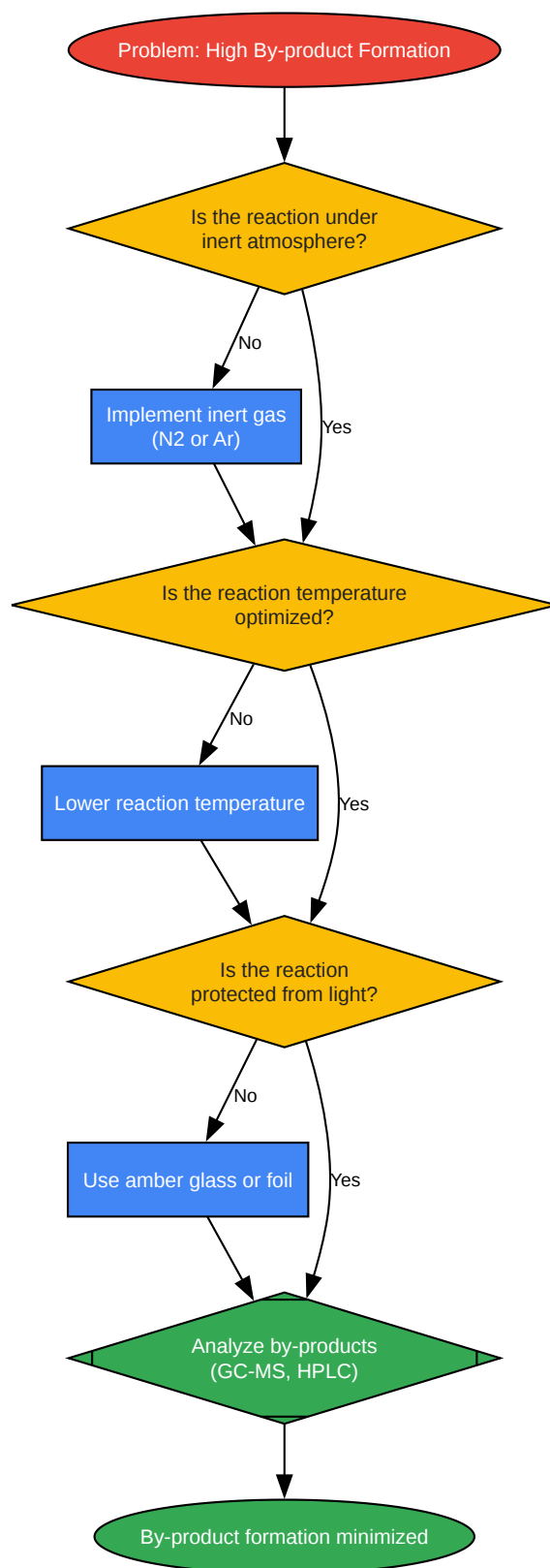

[Click to download full resolution via product page](#)

Caption: Troubleshooting workflow for minimizing BHT by-products.

Need Custom Synthesis?

BenchChem offers custom synthesis for rare earth carbides and specific isotopic labeling.

Email: info@benchchem.com or [Request Quote Online](#).

References

- 1. Butylated hydroxytoluene - Wikipedia [en.wikipedia.org]
- 2. MOTD BHT [iverson.cm.utexas.edu]
- 3. Thermal decomposition characteristics of BHT and its peroxide (BHTOOH) - PMC [pmc.ncbi.nlm.nih.gov]
- 4. Oxidation characteristics and thermal stability of Butylated hydroxytoluene - Arabian Journal of Chemistry [arabjchem.org]
- To cite this document: BenchChem. [Minimizing by-product formation in reactions involving BHT.]. BenchChem, [2025]. [Online PDF]. Available at: [https://www.benchchem.com/product/b512018#minimizing-by-product-formation-in-reactions-involving-bht]

Disclaimer & Data Validity:

The information provided in this document is for Research Use Only (RUO) and is strictly not intended for diagnostic or therapeutic procedures. While BenchChem strives to provide accurate protocols, we make no warranties, express or implied, regarding the fitness of this product for every specific experimental setup.

Technical Support: The protocols provided are for reference purposes. Unsure if this reagent suits your experiment? [[Contact our Ph.D. Support Team for a compatibility check](#)]

Need Industrial/Bulk Grade? [Request Custom Synthesis Quote](#)

BenchChem

Our mission is to be the trusted global source of essential and advanced chemicals, empowering scientists and researchers to drive progress in science and industry.

Contact

Address: 3281 E Guasti Rd

Ontario, CA 91761, United States

Phone: (601) 213-4426

Email: info@benchchem.com