

A Comparative Guide to the Structure-Activity Relationship of Phenoxy Acetamide Analogs

Author: BenchChem Technical Support Team. **Date:** May 2026

Compound of Interest

Compound Name: *2-phenoxy-N-(2-pyridinylmethyl)acetamide*

Cat. No.: B502687

[Get Quote](#)

In the landscape of medicinal chemistry, the phenoxy acetamide scaffold has emerged as a privileged structure, demonstrating a remarkable versatility in engaging a wide array of biological targets. This guide provides an in-depth, comparative analysis of the structure-activity relationships (SAR) of phenoxy acetamide analogs. By delving into the nuances of chemical modifications and their profound impact on pharmacological activity, we aim to equip researchers, scientists, and drug development professionals with the critical insights necessary for the rational design of novel therapeutics. This document moves beyond a mere recitation of facts to offer a synthesized understanding of the causality behind experimental outcomes, grounded in authoritative research.

The Phenoxy Acetamide Core: A Foundation for Diverse Bioactivity

The fundamental phenoxy acetamide structure, characterized by a phenoxy group linked to an acetamide moiety, serves as a versatile template for chemical elaboration. The inherent chemical properties of this core, including the potential for hydrogen bonding from the amide group and π - π stacking interactions from the phenyl ring, contribute to its ability to bind to various biological targets.^[1] Molecules incorporating this scaffold have been reported to exhibit

a wide spectrum of biological activities, including anti-cancer, anti-inflammatory, analgesic, anticonvulsant, and antimicrobial effects.[2][3] The amenability of the phenoxy and acetamide portions to substitution allows for the fine-tuning of pharmacokinetic and pharmacodynamic properties.

Structure-Activity Relationship (SAR) Analysis: Decoding the Impact of Chemical Modifications

The biological activity of phenoxy acetamide analogs is intricately linked to the nature and position of substituents on the phenoxy ring and the acetamide nitrogen. Understanding these relationships is paramount for optimizing potency, selectivity, and overall drug-like properties.

Substitutions on the Phenoxy Ring

Modifications to the phenoxy ring have a profound effect on the electronic and steric properties of the molecule, thereby influencing its interaction with target proteins.

- **Halogen Substituents:** The introduction of halogens, such as chlorine and fluorine, on the phenoxy ring has been shown to enhance various biological activities. For instance, halogen-containing phenoxy derivatives have demonstrated improved anti-inflammatory and anticancer properties.[2][4] This is often attributed to the ability of halogens to form halogen bonds and modulate the lipophilicity of the compound, potentially enhancing cell membrane permeability and target engagement.
- **Nitro Group:** The presence of a nitro group on the phenoxy ring has been associated with potent anticancer, anti-inflammatory, and analgesic activities.[2][4] The strong electron-withdrawing nature of the nitro group can significantly alter the electronic distribution of the molecule, potentially leading to stronger interactions with biological targets.
- **Methoxy Group:** The substitution of a methoxy group on the phenoxy ring has been explored in the context of monoamine oxidase (MAO) inhibition. For example, 2-(4-methoxyphenoxy)acetamide was identified as a specific MAO-A inhibitor.[5] The electron-donating nature of the methoxy group can influence the binding affinity and selectivity of the compound.

Modifications of the Acetamide Moiety

Alterations to the acetamide portion of the scaffold, particularly at the nitrogen atom, provide another avenue for modulating biological activity.

- **Aromatic and Heterocyclic Substituents:** The incorporation of various aromatic and heterocyclic rings on the acetamide nitrogen has led to the discovery of potent and selective inhibitors of various enzymes. For example, the synthesis of N-phenylacetamide sulphonamides has yielded compounds with significant analgesic activity.^[2]
- **Alkyl and Substituted Phenylalkyl Groups:** The nature of the substituent on the acetamide nitrogen can also influence the compound's selectivity and potency. For instance, in a series of 2-(substituted phenoxy)-N-(1-phenylethyl)acetamide derivatives, the substitution pattern on the 1-phenylethyl moiety was found to be critical for anticancer and anti-inflammatory activities.^[4]

Comparative Analysis of Phenoxy Acetamide Analogs

To illustrate the practical implications of the SAR principles discussed, the following table summarizes the biological activities of representative phenoxy acetamide analogs from various studies. This comparative data highlights how subtle structural modifications can lead to significant differences in potency and therapeutic potential.

Compound ID	Structure	Target/Activity	IC ₅₀ /Activity	Reference
1	2-(4-Methoxyphenoxy)acetamide	MAO-A Inhibition	SI = 245	[5]
2	(2-(4-((prop-2-ynylimino)methyl)phenoxy)acetamide	MAO-A/B Inhibition	IC ₅₀ MAO-A = 0.018 μM, IC ₅₀ MAO-B = 0.07 μM	[5]
3	N-(1-(4-chlorophenyl)ethyl)-2-(4-nitrophenoxy)acetamide	Anticancer (MCF-7), Anti-inflammatory, Analgesic	Exhibited potent activity	[4][6]
4	2-(3-fluoro-4-nitrophenoxy)-N-(2-nitrophenyl)acetamide	Antitubercular (M. tuberculosis H ₃₇ Rv)	MIC = 4 μg/mL	[7]
5	Compound I (a novel phenoxy acetamide derivative)	Anticancer (HepG2)	IC ₅₀ = 1.43 μM	[8]

Experimental Protocols

The synthesis and biological evaluation of phenoxy acetamide analogs are central to SAR studies. The following protocols provide a generalized framework for these key experimental workflows.

General Synthesis of Phenoxy Acetamide Analogs

The synthesis of phenoxy acetamide derivatives typically involves a two-step process: the formation of an α-haloacetamide intermediate followed by nucleophilic substitution with a substituted phenol.

Step 1: Synthesis of 2-Chloro-N-substituted-acetamide

- To a solution of the desired primary or secondary amine (1.0 eq.) in a suitable solvent (e.g., dichloromethane, DCM) at 0 °C, add a base such as triethylamine (1.2 eq.).
- Slowly add chloroacetyl chloride (1.1 eq.) to the reaction mixture.
- Allow the reaction to stir at room temperature for 2-4 hours, monitoring the progress by thin-layer chromatography (TLC).
- Upon completion, wash the reaction mixture with water and brine.
- Dry the organic layer over anhydrous sodium sulfate, filter, and concentrate under reduced pressure to yield the crude 2-chloro-N-substituted-acetamide, which can be purified by recrystallization or column chromatography.

Step 2: Synthesis of 2-(Substituted phenoxy)-N-substituted-acetamide

- To a solution of the substituted phenol (1.0 eq.) in a polar aprotic solvent (e.g., N,N-dimethylformamide, DMF), add a base such as potassium carbonate (1.5 eq.).
- Stir the mixture at room temperature for 30 minutes.
- Add the 2-chloro-N-substituted-acetamide (1.0 eq.) to the reaction mixture.
- Heat the reaction to 60-80 °C and stir for 4-12 hours, monitoring by TLC.
- After completion, pour the reaction mixture into ice-water and extract the product with a suitable organic solvent (e.g., ethyl acetate).
- Wash the combined organic layers with water and brine, dry over anhydrous sodium sulfate, and concentrate under reduced pressure.
- Purify the crude product by column chromatography or recrystallization to obtain the final phenoxy acetamide analog.

In Vitro Anticancer Activity Assay (MTT Assay)

The 3-(4,5-dimethylthiazol-2-yl)-2,5-diphenyltetrazolium bromide (MTT) assay is a colorimetric assay for assessing cell metabolic activity and is widely used to measure the cytotoxic effects of potential anticancer agents.[8]

- Seed cancer cells (e.g., MCF-7, HepG2) in a 96-well plate at a density of 5,000-10,000 cells per well and incubate for 24 hours.
- Treat the cells with various concentrations of the synthesized phenoxy acetamide analogs and a vehicle control.
- Incubate the plate for 48-72 hours at 37 °C in a humidified atmosphere with 5% CO₂.
- Add MTT solution (5 mg/mL in PBS) to each well and incubate for another 4 hours.
- Remove the medium and add dimethyl sulfoxide (DMSO) to dissolve the formazan crystals.
- Measure the absorbance at 570 nm using a microplate reader.
- Calculate the percentage of cell viability and determine the IC₅₀ value for each compound.

Visualizing Structure-Activity Relationships and Workflows

To further elucidate the concepts discussed, the following diagrams, generated using Graphviz, provide a visual representation of the SAR of phenoxy acetamide analogs and a typical experimental workflow.

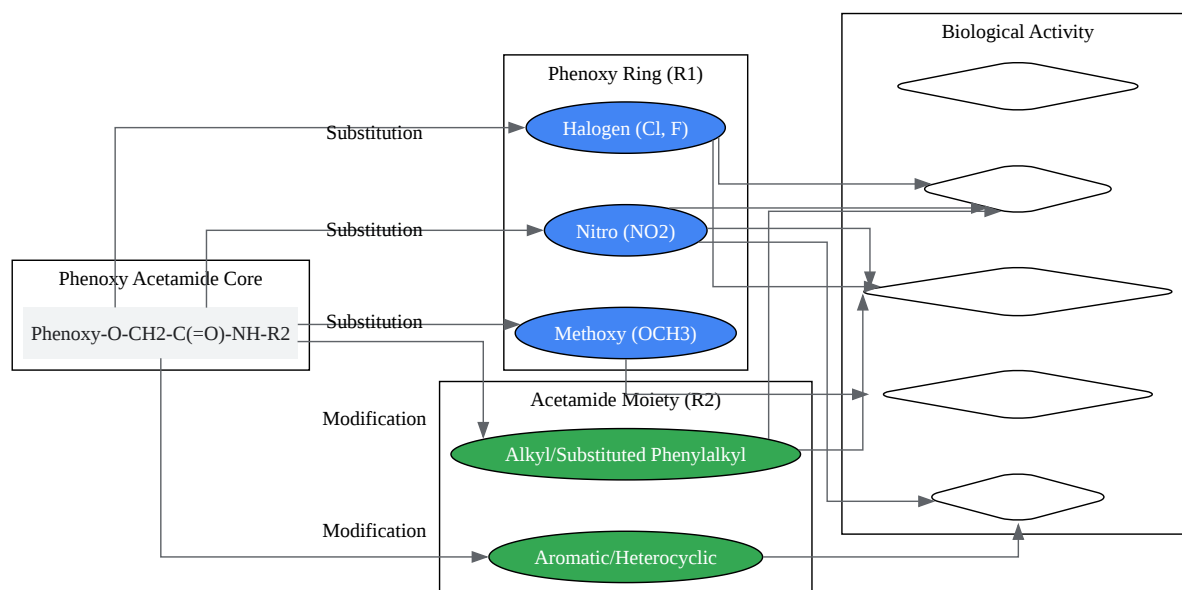

[Click to download full resolution via product page](#)

Caption: SAR of Phenoxy Acetamide Analogs.

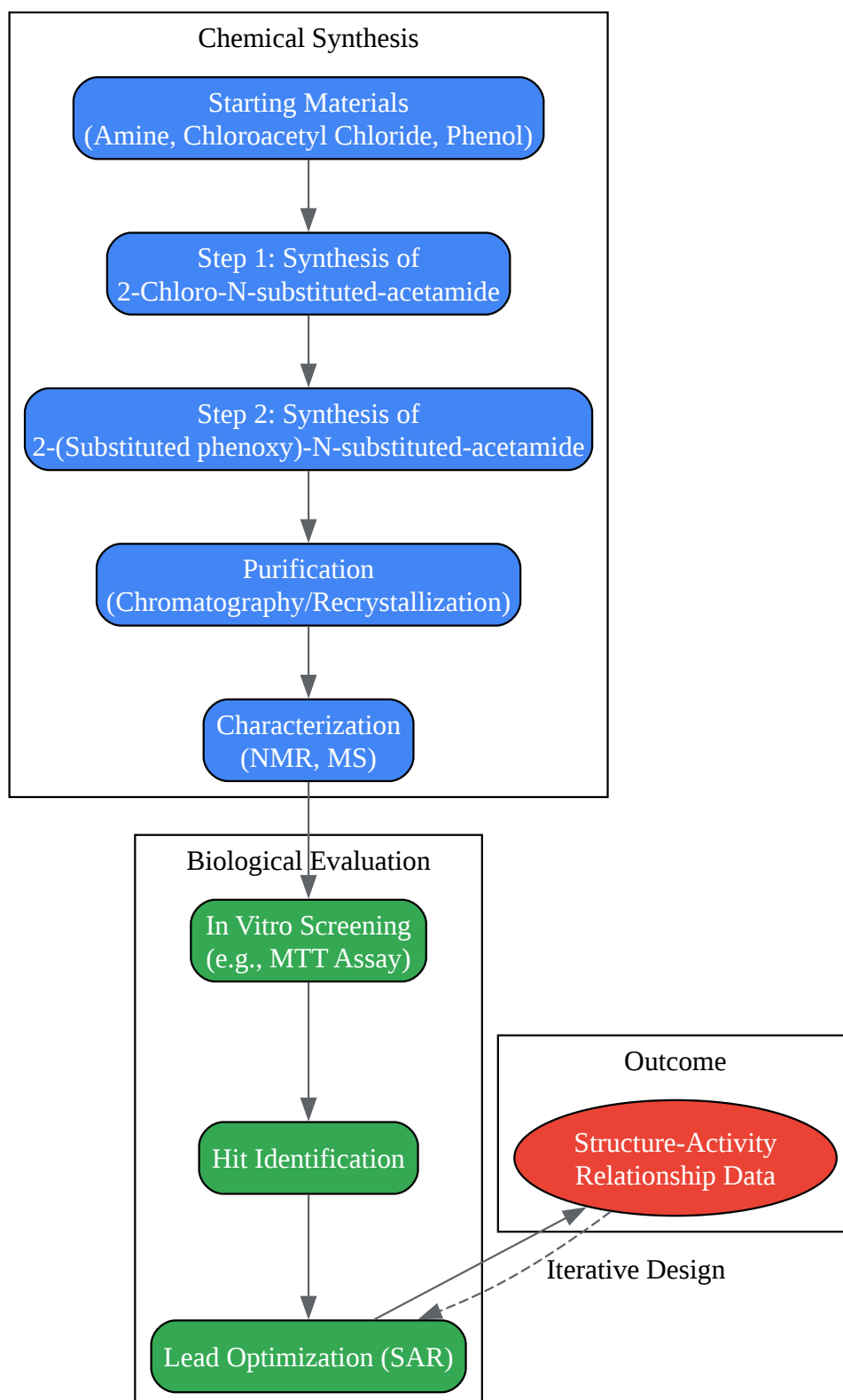

[Click to download full resolution via product page](#)

Caption: Experimental Workflow for SAR Studies.

Conclusion

The phenoxy acetamide scaffold represents a highly fruitful starting point for the development of novel therapeutic agents with a wide range of biological activities. A thorough understanding of the structure-activity relationships, driven by systematic chemical modifications and robust biological evaluation, is crucial for the successful design of potent and selective drug candidates. This guide has provided a comprehensive overview of the key SAR principles governing phenoxy acetamide analogs, supported by comparative data and detailed experimental protocols. By leveraging these insights, researchers can continue to unlock the full therapeutic potential of this versatile chemical class.

References

- Recent investigations into synthesis and pharmacological activities of phenoxy acetamide and its derivatives (chalcone, indole and quinoline) as possible therapeutic candidates. PMC. [\[Link\]](#)
- In Vitro and In Vivo Effects of Synthesis Novel Phenoxyacetamide Derivatives as Potent Apoptotic Inducer against HepG2 Cells through PARP-1 Inhibition. MDPI. [\[Link\]](#)
- Synthesis and biological evaluation of 2-phenoxyacetamide analogues, a novel class of potent and selective monoamine oxidase inhibitors. PubMed. [\[Link\]](#)
- An Overview of New Acetamide Derivatives in COX-II Inhibitors. Galaxy Publication. [\[Link\]](#)
- Anticancer, Anti-Inflammatory, and Analgesic Activities of Synthesized 2-(Substituted phenoxy) Acetamide Derivatives. ResearchGate. [\[Link\]](#)
- Synthesis and Biological Evaluation of 2-(3-Fluoro-4-nitro phenoxy)-N-phenylacetamide Derivatives as Novel Potential Affordable Antitubercular Agents. MDPI. [\[Link\]](#)
- Anticancer, anti-inflammatory, and analgesic activities of synthesized 2-(substituted phenoxy) acetamide derivatives. PubMed. [\[Link\]](#)

Need Custom Synthesis?

BenchChem offers custom synthesis for rare earth carbides and specific isotopic labeling.

Email: info@benchchem.com or [Request Quote Online](#).

Sources

- [1. pdf.benchchem.com \[pdf.benchchem.com\]](https://pdf.benchchem.com)
- [2. Recent investigations into synthesis and pharmacological activities of phenoxy acetamide and its derivatives \(chalcone, indole and quinoline\) as possible therapeutic candidates - PMC \[pmc.ncbi.nlm.nih.gov\]](#)
- [3. galaxypub.co \[galaxypub.co\]](https://galaxypub.co)
- [4. researchgate.net \[researchgate.net\]](https://researchgate.net)
- [5. Synthesis and biological evaluation of 2-phenoxyacetamide analogues, a novel class of potent and selective monoamine oxidase inhibitors - PubMed \[pubmed.ncbi.nlm.nih.gov\]](#)
- [6. Anticancer, anti-inflammatory, and analgesic activities of synthesized 2-\(substituted phenoxy\) acetamide derivatives - PubMed \[pubmed.ncbi.nlm.nih.gov\]](#)
- [7. Synthesis and Biological Evaluation of 2-\(3-Fluoro-4-nitro phenoxy\)-N-phenylacetamide Derivatives as Novel Potential Affordable Antitubercular Agents \[mdpi.com\]](#)
- [8. mdpi.com \[mdpi.com\]](https://mdpi.com)
- To cite this document: BenchChem. [A Comparative Guide to the Structure-Activity Relationship of Phenoxy Acetamide Analogs]. BenchChem, [2026]. [Online PDF]. Available at: [<https://www.benchchem.com/product/b502687/docs#a-comparative-guide-to-the-structure-activity-relationship-of-phenoxy-acetamide-analogs>]

Disclaimer & Data Validity:

The information provided in this document is for Research Use Only (RUO) and is strictly not intended for diagnostic or therapeutic procedures. While BenchChem strives to provide accurate protocols, we make no warranties, express or implied, regarding the fitness of this product for every specific experimental setup.

Technical Support: The protocols provided are for reference purposes. Unsure if this reagent suits your experiment?

Need Industrial/Bulk Grade? [Request Custom Synthesis Quote](#)

BenchChem

Our mission is to be the trusted global source of essential and advanced chemicals, empowering scientists and researchers to drive progress in science and industry.

Contact

Address: 3281 E Guasti Rd

Ontario, CA 91761, United States

Phone: (601) 213-4426

Email: info@benchchem.com

[Contact our Ph.D. Support Team for a compatibility check](#)