

Introduction: The Critical Role of Side-Chain Engineering in Conductive Polymers

Author: BenchChem Technical Support Team. **Date:** May 2026

Compound of Interest

Compound Name: 3-[(2-Ethylhexyl)oxy]thiophene

CAS No.: 125300-69-8

Cat. No.: B050212

[Get Quote](#)

Conductive polymers have revolutionized modern electronics by combining the electrical properties of semiconductors with the mechanical flexibility and solution processability of plastics. Among these materials, polythiophenes are a standout class, forming the active layer in a vast array of organic electronic devices.[1][2] However, the pristine polythiophene backbone is rigid and insoluble, severely limiting its practical application.[3]

This challenge is overcome through side-chain engineering: the strategic attachment of functional groups to the thiophene monomer. The introduction of alkyl or alkoxy side chains at the 3-position of the thiophene ring disrupts intermolecular packing just enough to render the resulting polymer soluble in common organic solvents.[4][5] This allows for the formation of high-quality thin films using simple, scalable techniques like spin coating.

This application note focuses on **3-[(2-Ethylhexyl)oxy]thiophene**, a key precursor for synthesizing a highly soluble and electronically active conductive polymer. The branched (2-ethylhexyl)oxy side chain provides excellent solubility, while the oxygen linker fine-tunes the electronic properties of the polymer backbone. We will provide a comprehensive overview of this monomer, detailed protocols for its polymerization and film deposition, and methods for

characterizing the final polymer, empowering researchers to leverage this material in next-generation organic electronics.[6][7]

Monomer Profile: 3-[(2-Ethylhexyl)oxy]thiophene

Understanding the precursor is fundamental to controlling the final polymer's properties. The (2-ethylhexyl)oxy side chain is not arbitrary; its branched nature is highly effective at preventing the excessive aggregation that can lead to poor solubility, a common issue with straight-chain substituted polythiophenes.

Property	Value
Chemical Name	3-[(2-Ethylhexyl)oxy]thiophene
Molecular Formula	C ₁₂ H ₂₀ OS
Molecular Weight	212.35 g/mol
Appearance	Colorless to pale yellow liquid
Key Feature	Branched alkoxy side-chain enhances solubility in organic solvents like chloroform, chlorobenzene, and toluene.[8]

Polymerization: From Monomer to Conjugated Macromolecule

The conversion of 3-[(2-Ethylhexyl)oxy]thiophene monomers into a conjugated polymer, poly(3-[(2-Ethylhexyl)oxy]thiophene) or P(3EHO)T, is typically achieved through oxidative coupling. This process links the monomers at their 2 and 5 positions, creating the π -conjugated backbone necessary for charge transport.[3]

Mechanism: Oxidative Chemical Polymerization

The most common laboratory-scale method for synthesizing poly(3-alkylthiophene)s is oxidative polymerization using an oxidant such as iron (III) chloride (FeCl₃).[5][9] The reaction proceeds through a well-understood multi-step mechanism:

- Oxidation: The oxidant (Fe^{3+}) removes an electron from the thiophene monomer, creating a radical cation.
- Dimerization: Two radical cations couple to form a dimer.
- Deprotonation: The dimer loses two protons to regain aromaticity.
- Propagation: The dimer is re-oxidized, and the process repeats, extending the polymer chain.[\[9\]](#)[\[10\]](#)

This process is highly effective but must be carefully controlled to achieve polymers with desirable molecular weights and high "regioregularity" (the consistency of head-to-tail linkages), which is critical for optimal electronic performance.[\[11\]](#)

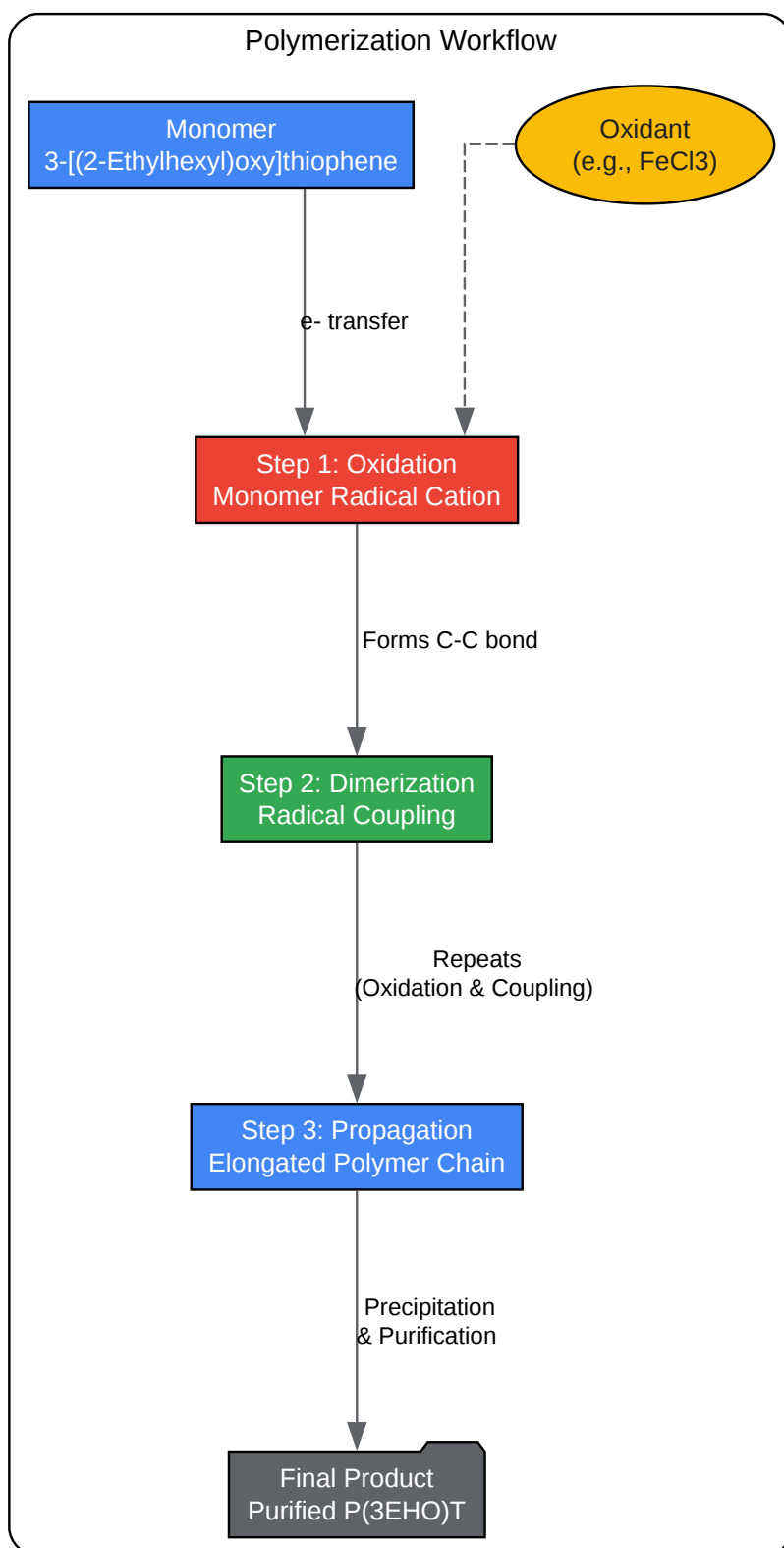

[Click to download full resolution via product page](#)

Caption: Oxidative polymerization workflow for P(3EHO)T.

Experimental Protocols

The following protocols provide a robust starting point for the synthesis of P(3EHO)T and its fabrication into thin films.

Protocol 1: Synthesis via Oxidative Polymerization

This protocol is adapted from established methods for poly(3-hexylthiophene) and is expected to yield a polymer with good solubility and electronic properties.[\[5\]](#)[\[9\]](#)

A. Materials and Key Parameters

Parameter	Recommended Value/Material	Rationale & Causality
Monomer	3-[(2-Ethylhexyl)oxy]thiophene	The precursor to the conductive polymer.
Oxidant	Anhydrous Iron (III) Chloride (FeCl ₃)	A strong and common oxidant for thiophene polymerization. [5]
Solvent	Anhydrous Chloroform or Dichloromethane	Must be anhydrous to prevent quenching the reaction. Chloroform tends to yield higher molecular weight polymer.[5]
Monomer:Oxidant Ratio	1 : 4 (molar)	A stoichiometric excess of oxidant ensures complete monomer conversion.
Reaction Atmosphere	Inert (Nitrogen or Argon)	Prevents unwanted side reactions with oxygen and moisture.
Precipitation Solvent	Methanol	The polymer is insoluble in methanol, allowing it to precipitate out while impurities and unreacted species remain dissolved.
Purification Method	Soxhlet Extraction	Sequentially removes residual oxidant (methanol wash), oligomers (hexane wash), and isolates the desired polymer fraction (chloroform wash).

B. Step-by-Step Methodology

- Setup: Assemble a flame-dried, three-neck round-bottom flask equipped with a condenser, a nitrogen/argon inlet, and a rubber septum. Maintain a positive pressure of inert gas

throughout the reaction.

- **Oxidant Suspension:** In a separate dry flask, suspend anhydrous FeCl_3 (4.0 eq) in anhydrous chloroform (50 mL per gram of monomer) and stir vigorously.
- **Monomer Addition:** Using a gas-tight syringe, slowly add **3-[(2-Ethylhexyl)oxy]thiophene** (1.0 eq) to the stirred FeCl_3 suspension over 20-30 minutes. The reaction is exothermic and the solution should darken to a deep blue/black color, indicating polymerization.
- **Reaction:** Allow the reaction to stir at room temperature for 12-24 hours under an inert atmosphere.
- **Quenching & Precipitation:** Slowly pour the reaction mixture into a beaker containing vigorously stirring methanol (approx. 10x the volume of chloroform used). A dark solid (the crude polymer) should immediately precipitate.
- **Initial Filtration:** Continue stirring for 30 minutes, then collect the crude polymer by vacuum filtration. Wash the solid with copious amounts of methanol until the filtrate runs clear.
- **Purification (Soxhlet Extraction):**
 - Dry the crude polymer and load it into a cellulose extraction thimble.
 - Perform sequential Soxhlet extractions: first with methanol (to remove residual salts), then with hexane (to remove low molecular weight oligomers).
 - Finally, extract the desired polymer fraction with chloroform. The chloroform solution will be a deep orange/red color.
- **Final Recovery:** Reduce the volume of the chloroform solution via rotary evaporation. Precipitate the purified polymer by adding it dropwise into stirring methanol.
- **Drying:** Collect the final fibrous polymer by vacuum filtration and dry it under vacuum at 40-50 °C for at least 24 hours.

Protocol 2: Thin Film Fabrication by Spin Coating

Spin coating is a premier technique for producing uniform thin films from solution, essential for device fabrication.[12]

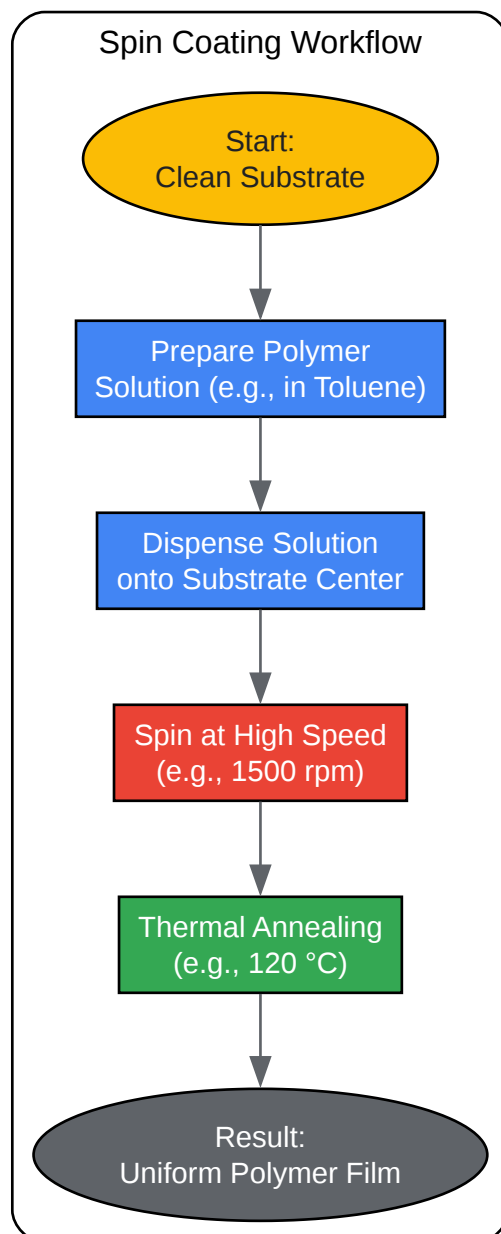

[Click to download full resolution via product page](#)

Caption: General workflow for thin film deposition via spin coating.

A. Parameters and Their Influence

Parameter	Recommended Starting Range	Influence on Film Properties
Solvent	Chlorobenzene, Toluene, Xylene	Higher boiling point solvents evaporate slower, allowing more time for polymer chains to self-organize, potentially leading to higher crystallinity. [13]
Polymer Concentration	5 - 20 mg/mL	Higher concentration generally results in thicker films. [13]
Spin Speed	1000 - 4000 rpm	Higher spin speeds produce thinner films due to increased centrifugal force. [13]
Spin Time	30 - 60 seconds	Sufficient time is needed to ensure solvent evaporation and film uniformity.
Annealing Temperature	100 - 150 °C	Post-deposition annealing enhances polymer chain packing and crystallinity, which is crucial for improving charge carrier mobility. [14]

B. Step-by-Step Methodology

- **Substrate Cleaning:** Thoroughly clean the substrate (e.g., glass, silicon wafer, ITO-coated glass) by sequential sonication in detergent, deionized water, acetone, and isopropanol. Dry the substrate with a stream of nitrogen. An optional oxygen plasma or UV-Ozone treatment can further improve surface cleanliness and wettability.
- **Solution Preparation:** Dissolve the purified P(3EHO)T in a suitable solvent (e.g., chlorobenzene) at the desired concentration. Gently heat (40-50 °C) and stir overnight to ensure complete dissolution. Before use, filter the solution through a 0.2 µm PTFE syringe filter to remove any aggregates.

- Spin Coating:
 - Place the cleaned substrate on the spin coater chuck and apply vacuum.
 - Dispense a sufficient amount of the polymer solution to cover the substrate center.
 - Start the spin program (e.g., 1500 rpm for 60 seconds). A two-step program can be used to improve uniformity and remove the "edge bead".[\[12\]](#)
- Thermal Annealing: Transfer the coated substrate onto a calibrated hotplate in an inert environment (e.g., a nitrogen-filled glovebox). Anneal at the desired temperature (e.g., 120 °C) for 10-30 minutes.
- Cool Down: Allow the film to cool to room temperature slowly before removal for characterization.

Validation: Characterizing the Polymer and Film

Verifying the properties of the synthesized polymer is a critical step.

Technique	Purpose	Expected Result/Observation
¹ H NMR Spectroscopy	Confirm polymer structure and determine regioregularity.	A characteristic peak for the thiophene ring proton around 6.98 ppm indicates a high degree of head-to-tail regioregularity.[11] Multiple peaks in the 7.00-7.05 ppm range suggest a more regioirregular structure.[11]
UV-Vis Spectroscopy	Determine the optical absorption profile and estimate the bandgap.	A broad absorption peak in the visible spectrum (e.g., 450-600 nm) is characteristic of a conjugated polythiophene. The onset of absorption can be used to calculate the optical bandgap.[15]
Cyclic Voltammetry (CV)	Determine HOMO and LUMO energy levels.	The onset potentials of oxidation and reduction waves are used to calculate the electrochemical energy levels, which are crucial for predicting device performance.[6]
Four-Point Probe	Measure the electrical conductivity of the thin film.	Conductivity values for doped polythiophenes can range widely, from 10 ⁻⁵ to over 10 ² S/cm, depending on regioregularity, morphology, and doping level.[6]

Applications in Organic Electronics

The excellent solubility and semiconducting properties of P(3EHO)T make it a versatile material for various organic electronic devices.

- Organic Field-Effect Transistors (OFETs): The polymer serves as the active semiconductor layer, where its ability to form ordered, crystalline domains after annealing allows for efficient charge transport between the source and drain electrodes.[1][7]
- Organic Photovoltaics (OPVs): In OPVs, the polymer typically acts as the electron donor material, absorbing sunlight to create excitons (electron-hole pairs) and transporting the resulting holes to the anode.[7]
- Sensors: The conductivity of the polymer film can be modulated by the presence of certain chemical analytes, making it a promising material for low-cost chemical sensors.[1]

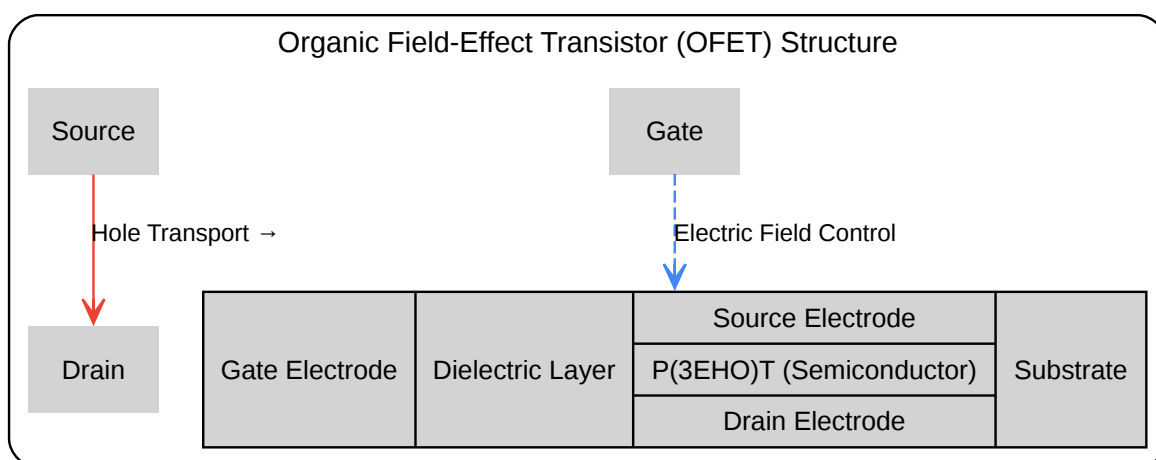

[Click to download full resolution via product page](#)

Caption: A typical bottom-gate, bottom-contact OFET device structure.

References

- 3-(2-Ethylhexyl)thiophene 121134-38-1. Sigma-Aldrich.
- Poly(3,4-ethylenedioxythiophene) Conductive Polymer. Ossila.
- Studies on 3-(2-Ethylhexyl)thiophene Polymers.
- Modifying the conductive properties of poly(3,4-ethylenedioxythiophene) thin films in green solvents. Frontiers.
- Poly(3,4-ethylenedioxythiophene) (PEDOT) Derivatives: Innovative Conductive Polymers for Bioelectronics. MDPI.
- Progress in Synthesis of Conductive Polymer Poly(3,4-Ethylenedioxythiophene). Frontiers.

- Understanding the Chemical Properties and Applications of 3-(2-Ethylhexyl)thiophene. NINGBO INNO PHARMCHEM CO.,LTD.
- Interfacial and confined molecular-assembly of poly(3-hexylthiophene) and its application in organic electronic devices.
- Recent developments in the synthesis of regioregular thiophene-based conjugated polymers for electronic and optoelectronic applications using nickel and palladium-based catalytic systems. Royal Society of Chemistry.
- Vapor phase polymerization of thieno[3,4-b]thiophene–tosylate and its application for dynamic structural color
- Application Note: Protocol for Spin Coating Poly(3-(6-Methoxyhexyl)thiophene) Films. Benchchem.
- Synthesis of Highly Conductive Poly(3-hexylthiophene)
- The Synthesis and Characterization of Thiophene Deriv
- Influence of solvent used on oxidative polymerization of Poly(3-hexylthiophene) in their chemical properties. Redalyc.
- Vapor Phase Polymerization of Pyrrole and Thiophene Using Iron(III) Sulfonates as Oxidizing Agents.
- Spin Coating: Complete Guide to Theory and Techniques. Ossila.
- The Impact of Physical Form on the Biocompatibility of Poly(3-hexylthiophene-2,5-diyl).
- Morphological and Optical Studies of Poly(3-hexylthiophene) Deposited by Spin Coating on Various Substrates.
- Poly(3-hexylthiophene)-Based Organic Thin-Film Transistors with Virgin Graphene Oxide as an Interfacial Layer. MDPI.
- Thiophene - Wikipedia. Wikipedia.
- Developments in polytellurophenes and tellurophene-containing polymers: from synthesis to applic
- Microscopic, Spectroscopic, and Electrochemical Characterization of Novel Semicrystalline Poly(3-hexylthiophene)-Based Dendritic Star Copolymer. MDPI.

Need Custom Synthesis?

BenchChem offers custom synthesis for rare earth carbides and specific isotopic labeling.

Email: info@benchchem.com or [Request Quote Online](#).

Sources

- [1. mdpi.com \[mdpi.com\]](https://www.mdpi.com)

- [2. Developments in polytellurophenes and tellurophene-containing polymers: from synthesis to applications - Polymer Chemistry \(RSC Publishing\) DOI:10.1039/D5PY00439J \[pubs.rsc.org\]](#)
- [3. Thiophene - Wikipedia \[en.wikipedia.org\]](#)
- [4. Recent developments in the synthesis of regioregular thiophene-based conjugated polymers for electronic and optoelectronic applications using nickel a ... - RSC Advances \(RSC Publishing\) DOI:10.1039/C9RA09712K \[pubs.rsc.org\]](#)
- [5. Influence of solvent used on oxidative polymerization of Poly\(3-hexylthiophene\) in their chemical properties \[redalyc.org\]](#)
- [6. researchgate.net \[researchgate.net\]](#)
- [7. Interfacial and confined molecular-assembly of poly\(3-hexylthiophene\) and its application in organic electronic devices - PMC \[pmc.ncbi.nlm.nih.gov\]](#)
- [8. nbinno.com \[nbinno.com\]](#)
- [9. mdpi.com \[mdpi.com\]](#)
- [10. ossila.com \[ossila.com\]](#)
- [11. Microscopic, Spectroscopic, and Electrochemical Characterization of Novel Semicrystalline Poly\(3-hexylthiophene\)-Based Dendritic Star Copolymer \[mdpi.com\]](#)
- [12. ossila.com \[ossila.com\]](#)
- [13. pdf.benchchem.com \[pdf.benchchem.com\]](#)
- [14. The Impact of Physical Form on the Biocompatibility of Poly\(3-hexylthiophene-2,5-diyl\) - PMC \[pmc.ncbi.nlm.nih.gov\]](#)
- [15. researchgate.net \[researchgate.net\]](#)
- [To cite this document: BenchChem. \[Introduction: The Critical Role of Side-Chain Engineering in Conductive Polymers\]. BenchChem, \[2026\]. \[Online PDF\]. Available at: \[https://www.benchchem.com/product/b050212/docs#introduction-the-critical-role-of-side-chain-engineering-in-conductive-polymers\]](#)

Disclaimer & Data Validity:

The information provided in this document is for Research Use Only (RUO) and is strictly not intended for diagnostic or therapeutic procedures. While BenchChem strives to provide accurate protocols, we make no warranties, express or implied, regarding the fitness of this product for every specific experimental setup.

Technical Support: The protocols provided are for reference purposes. Unsure if this reagent suits your experiment?

Need Industrial/Bulk Grade? [Request Custom Synthesis Quote](#)

BenchChem

Our mission is to be the trusted global source of essential and advanced chemicals, empowering scientists and researchers to drive progress in science and industry.

Contact

Address: 3281 E Guasti Rd
Ontario, CA 91761, United States
Phone: (601) 213-4426
Email: info@benchchem.com

[Contact our Ph.D. Support Team for a compatibility check](#)