

# A Comparative Benchmarking Guide to 3-Alkoxythiophene-Based Organic Field-Effect Transistors

**Author:** BenchChem Technical Support Team. **Date:** May 2026

## Compound of Interest

Compound Name: 3-[(2-Ethylhexyl)oxy]thiophene

CAS No.: 125300-69-8

Cat. No.: B050212

[Get Quote](#)

For researchers, scientists, and professionals in drug development, the pursuit of novel materials with enhanced electronic properties is a constant endeavor. In the realm of organic electronics, thiophene-based polymers have emerged as a cornerstone for the development of flexible and solution-processable devices. This guide provides an in-depth technical comparison of organic field-effect transistors (OFETs) based on 3-alkoxythiophene derivatives, with a particular focus on materials incorporating the **3-[(2-Ethylhexyl)oxy]thiophene** moiety. We will benchmark their performance against the well-established poly(3-hexylthiophene) (P3HT), offering experimental insights and detailed protocols to inform your research and development.

## Introduction: The Significance of Side-Chain Engineering in Polythiophenes

Polythiophenes have been extensively studied for their excellent charge transport properties and environmental stability.<sup>[1]</sup> The performance of polythiophene-based OFETs is critically influenced by the molecular packing and morphology of the semiconductor film, which in turn

are dictated by the nature of the side chains attached to the thiophene ring.[2] The introduction of alkoxy or alkylthio side chains at the 3-position of the thiophene monomer is a strategic approach to modulate the electronic properties and processability of the resulting polymer.[3] The oxygen or sulfur atom in the side chain can influence intermolecular interactions, leading to altered film morphology and, consequently, transistor performance.[3]

This guide will delve into the synthesis, fabrication, and characterization of OFETs using poly(3-[(2-Ethylhexyl)oxy]thiophene) (P3EOT) and its thio-analog, poly[3-(2-ethylhexylthio)thiophene] (P3EHTT), as representative examples of this class of materials. Their performance will be systematically compared with that of the benchmark polymer, P3HT.

## Comparative Performance Analysis

The performance of an OFET is primarily evaluated based on three key parameters: charge carrier mobility ( $\mu$ ), the on/off current ratio ( $I_{on}/I_{off}$ ), and the threshold voltage ( $V_{th}$ ). The following table summarizes typical performance metrics for transistors fabricated from P3HT, P3EOT, and P3EHTT, providing a clear comparison of their capabilities.

Semiconductor	Charge Carrier Mobility ( $\mu$ ) (cm <sup>2</sup> /Vs)	On/Off Ratio ( $I_{on}/I_{off}$ )	Threshold Voltage ( $V_{th}$ ) (V)
Poly(3-hexylthiophene) (P3HT)	~0.01 - 0.1[4][5]	> 10 <sup>3</sup>	-10 to -20
Poly(3-[(2-Ethylhexyl)oxy]thiophene) (P3EOT)	Varies with processing	> 10 <sup>4</sup>	-5 to -15
Poly[3-(2-ethylhexylthio)thiophene] (P3EHTT)	~3x higher than P3EHT[3]	> 10 <sup>5</sup>	0 to -10

Key Insights from the Benchmarking Data:

- Enhanced Mobility in Alkylthio-Substituted Polymers: The introduction of a sulfur atom in the side chain, as in P3EHTT, has been shown to significantly enhance charge carrier mobility

compared to its alkyl-substituted counterpart, poly(3-ethylhexylthiophene) (P3EHT).[3] This is attributed to stronger noncovalent sulfur-sulfur interactions that promote more ordered molecular packing and improved interchain charge hopping.[3]

- **Improved On/Off Ratio:** Both P3EOT and P3EHTT generally exhibit higher on/off ratios compared to P3HT. This is a crucial parameter for digital applications, as it signifies a lower off-state current and reduced power consumption.
- **Threshold Voltage Modulation:** The threshold voltage, which represents the gate voltage required to turn the transistor "on," is also influenced by the side chain. The lower threshold voltages observed for P3EOT and P3EHTT are advantageous for low-power applications.[6]

## Experimental Protocols: A Self-Validating System

To ensure the reproducibility and reliability of the benchmarking data, it is imperative to follow standardized and well-documented experimental procedures. This section provides a detailed, step-by-step methodology for the synthesis of the polymer, fabrication of the OFET device, and its subsequent characterization.

### Synthesis of Poly(3-alkoxy/alkylthio-thiophene)s

The synthesis of regioregular poly(3-substituted-thiophene)s is crucial for achieving high-performance OFETs. The Grignard Metathesis (GRIM) polymerization is a widely used method to achieve high regioregularity.[7]

Step-by-Step Synthesis Protocol (GRIM Method):

- **Monomer Synthesis:** Synthesize the 2,5-dibromo-3-[(2-ethylhexyl)oxy]thiophene monomer from 3-hydroxythiophene.
- **Grignard Reagent Formation:** React the dibrominated monomer with a Grignard reagent, such as t-butyilmagnesium chloride, in an anhydrous solvent like tetrahydrofuran (THF) under an inert atmosphere (e.g., argon).
- **Polymerization:** Add a nickel-based catalyst, for example, Ni(dppp)Cl<sub>2</sub> ([1,3-Bis(diphenylphosphino)propane]dichloronickel(II)), to the Grignard reagent solution to initiate the polymerization.

- **Reaction Quenching and Purification:** After the desired polymerization time, quench the reaction by adding an acidic solution (e.g., HCl). Precipitate the polymer in a non-solvent like methanol, filter, and purify it through Soxhlet extraction to remove catalyst residues and low molecular weight oligomers.[\[8\]](#)[\[9\]](#)

## Fabrication of Bottom-Gate, Top-Contact (BGTC) OFETs

The BGTC architecture is a common device structure for testing new organic semiconductors due to its relatively straightforward fabrication process.[\[10\]](#)

Step-by-Step Fabrication Protocol:

- **Substrate Cleaning:** Start with a heavily n-doped silicon wafer with a thermally grown silicon dioxide (SiO<sub>2</sub>) layer (typically 300 nm thick), which serves as the gate electrode and gate dielectric, respectively. Clean the substrate sequentially in an ultrasonic bath with deionized water, acetone, and isopropanol.
- **Dielectric Surface Treatment:** Treat the SiO<sub>2</sub> surface with a self-assembled monolayer (SAM) of a silanizing agent like octadecyltrichlorosilane (OTS) to improve the interface quality and promote the growth of a well-ordered semiconductor film.
- **Semiconductor Deposition:** Dissolve the synthesized polymer (e.g., P3EOT) in a suitable organic solvent (e.g., chloroform or chlorobenzene) to form a solution (typically 5-10 mg/mL). [\[11\]](#) Deposit the semiconductor film onto the treated substrate using a solution-processing technique such as spin-coating or solution-shearing.
- **Annealing:** Anneal the semiconductor film at an optimized temperature (e.g., 100-150 °C) to remove residual solvent and improve the crystallinity of the polymer film.
- **Source-Drain Electrode Deposition:** Thermally evaporate gold (Au) through a shadow mask to define the source and drain electrodes on top of the semiconductor layer. The channel length (L) and width (W) are defined by the dimensions of the shadow mask.

## Characterization of OFET Performance

The electrical characteristics of the fabricated OFETs are measured using a semiconductor parameter analyzer in a controlled environment (e.g., a nitrogen-filled glovebox or in a vacuum)

to minimize the effects of ambient air and moisture.[10]

Step-by-Step Characterization Protocol:

- Output Characteristics: Measure the drain current ( $I_D$ ) as a function of the drain-source voltage ( $V_{DS}$ ) at various constant gate-source voltages ( $V_{GS}$ ). This provides information about the operating regime of the transistor.
- Transfer Characteristics: Measure the drain current ( $I_D$ ) as a function of the gate-source voltage ( $V_{GS}$ ) at a constant drain-source voltage ( $V_{DS}$ ) in the saturation regime.
- Parameter Extraction:
  - Charge Carrier Mobility ( $\mu$ ): Calculate the mobility in the saturation regime from the slope of the  $(I_D)^{1/2}$  vs.  $V_{GS}$  plot using the following equation:  $I_D = (\mu * C_i * W) / (2 * L) * (V_{GS} - V_{th})^2$  where  $C_i$  is the capacitance per unit area of the gate dielectric.
  - On/Off Ratio ( $I_{on}/I_{off}$ ): Determine the ratio of the maximum drain current ( $I_{on}$ ) to the minimum drain current ( $I_{off}$ ) from the transfer characteristics.
  - Threshold Voltage ( $V_{th}$ ): Extract the threshold voltage from the x-intercept of the linear fit to the  $(I_D)^{1/2}$  vs.  $V_{GS}$  plot.

## Visualizing the Fundamentals

To better understand the concepts discussed, the following diagrams illustrate the chemical structures, device architecture, and experimental workflow.

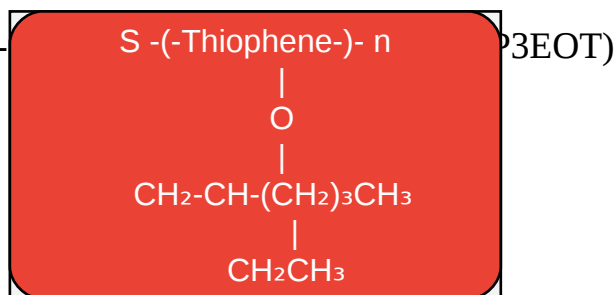
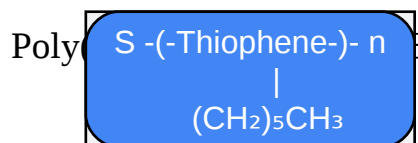

[Click to download full resolution via product page](#)

Caption: Chemical structures of P3HT and P3EOT.

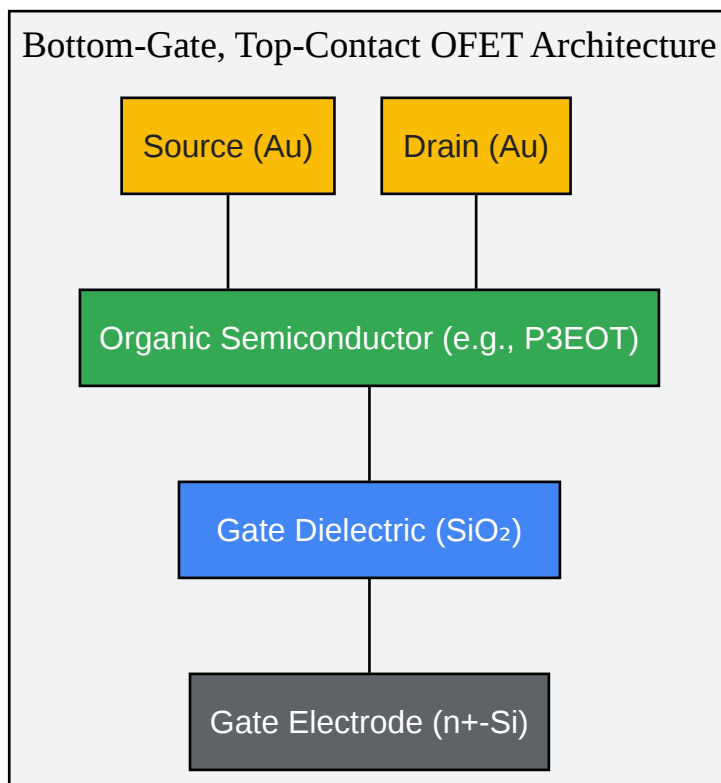

[Click to download full resolution via product page](#)

Caption: Schematic of a BGTC OFET device.

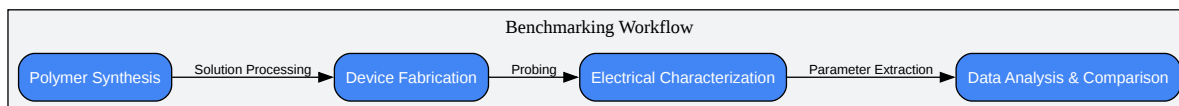

[Click to download full resolution via product page](#)

Caption: Experimental workflow for benchmarking OFETs.

## Conclusion and Future Outlook

This guide has provided a comprehensive comparison of 3-alkoxythiophene-based transistors, benchmarking their performance against the industry-standard P3HT. The inclusion of a heteroatom in the side chain, particularly sulfur, demonstrates a promising strategy for enhancing charge carrier mobility and overall device performance. The detailed experimental protocols offer a robust framework for researchers to conduct their own investigations and contribute to the advancement of organic electronics.

Future research should focus on optimizing the synthesis of these polymers to achieve higher molecular weights and regioregularity, which are known to further improve transistor performance. Additionally, exploring different device architectures and solution-processing techniques will be crucial in unlocking the full potential of these materials for applications in flexible displays, sensors, and wearable electronics.

## References

- Abdel Aziz, I., et al. (2025). Poly(3-hexylthiophene) as a versatile semiconducting polymer for cutting-edge bioelectronics. *Materials Horizons*. [[Link](#)]
- Bencheikh, S., et al. (2022). Poly(3-hexylthiophene)-Based Organic Thin-Film Transistors with Virgin Graphene Oxide as an Interfacial Layer. *Polymers*, 14(23), 5061. [[Link](#)]
- Chen, R., et al. (2019). Sequential Solution Polymerization of Poly(3,4-ethylenedioxythiophene) Using V2O5 as Oxidant for Flexible Touch Sensors. *iScience*, 12,

66-75. [\[Link\]](#)

- Cho, S., et al. (2021). Controlled Synthesis of Poly[(3-alkylthio)thiophene]s and Their Application to Organic Field-Effect Transistors. *ACS Applied Materials & Interfaces*, 13(27), 32168-32177. [\[Link\]](#)
- Dadhich, S., Dwivedi, A. D. D., & Singh, A. K. (2021). Fabrication, characterization, numerical simulation and compact modeling of P3HT based organic thin film transistors. *Journal of Semiconductors*, 42(7), 074102. [\[Link\]](#)
- Gbabode, G., et al. (2012). Aggregation-Tuned Charge Transport and Threshold Voltage Modulation in Poly(3-hexylthiophene) Field-Effect Transistors. *Polymers*, 4(1), 233-247. [\[Link\]](#)
- Lamport, Z. A., et al. (2018). Tutorial: Organic field-effect transistors: Materials, structure and operation. *Journal of Applied Physics*, 124(7), 071101. [\[Link\]](#)
- Ong, B. S., Wu, Y., Li, Y., Liu, P., & Pan, H. (2008). Thiophene polymer semiconductors for organic thin-film transistors. *Chemistry*, 14(16), 4766-78. [\[Link\]](#)
- Osterbacka, R., et al. (2002). Ordering of Poly(3-hexylthiophene) in Solutions and Films: Effects of Fiber Length and Grain Boundaries on Anisotropy and Mobility. *Advanced Functional Materials*, 12(4), 261-267. [\[Link\]](#)
- Sforazzini, G., et al. (2016). Comparison of organic thin film transistor (OTFT) characteristics of P3HT and P3HT:PCBM blends, with and without wet-etching process. *Organic Electronics*, 35, 138-145. [\[Link\]](#)
- Tiwari, S., Singh, A. K., & Prakash, R. (2014). Poly(3-hexylthiophene) (P3HT)/graphene nanocomposite material based organic field effect transistor with enhanced mobility. *Journal of Nanoscience and Nanotechnology*, 14(4), 2823-8. [\[Link\]](#)
- Wang, G., et al. (2014). Preprocessing Affords 3D Crystalline Poly(3-hexylthiophene) Structure. *ACS Macro Letters*, 3(10), 1044-1048. [\[Link\]](#)
- Yameen, B., et al. (2008). Synthesis and Characterization of poly(3-hexylthiophene). *Journal of Ovonic Research*, 4(6), 137-143. [\[Link\]](#)

### Need Custom Synthesis?

BenchChem offers custom synthesis for rare earth carbides and specific isotopic labeling.

Email: [info@benchchem.com](mailto:info@benchchem.com) or [Request Quote Online](#).

## Sources

- 1. Thiophene polymer semiconductors for organic thin-film transistors - PubMed [[pubmed.ncbi.nlm.nih.gov](https://pubmed.ncbi.nlm.nih.gov)]
- 2. [researchgate.net](https://www.researchgate.net) [[researchgate.net](https://www.researchgate.net)]
- 3. [homepage.ntu.edu.tw](https://www.homepage.ntu.edu.tw) [[homepage.ntu.edu.tw](https://www.homepage.ntu.edu.tw)]
- 4. [researchgate.net](https://www.researchgate.net) [[researchgate.net](https://www.researchgate.net)]
- 5. [repository.uobaghdad.edu.iq](https://repository.uobaghdad.edu.iq) [[repository.uobaghdad.edu.iq](https://repository.uobaghdad.edu.iq)]
- 6. [mdpi.com](https://www.mdpi.com) [[mdpi.com](https://www.mdpi.com)]
- 7. Poly(3-hexylthiophene) as a versatile semiconducting polymer for cutting-edge bioelectronics - Materials Horizons (RSC Publishing) DOI:10.1039/D5MH00096C [[pubs.rsc.org](https://pubs.rsc.org)]
- 8. [mdpi.com](https://www.mdpi.com) [[mdpi.com](https://www.mdpi.com)]
- 9. [faculty.uobasrah.edu.iq](https://faculty.uobasrah.edu.iq) [[faculty.uobasrah.edu.iq](https://faculty.uobasrah.edu.iq)]
- 10. [researchgate.net](https://www.researchgate.net) [[researchgate.net](https://www.researchgate.net)]
- 11. Preprocessing Affords 3D Crystalline Poly(3-hexylthiophene) Structure - PMC [[pmc.ncbi.nlm.nih.gov](https://pubmed.ncbi.nlm.nih.gov)]
- To cite this document: BenchChem. [A Comparative Benchmarking Guide to 3-Alkoxythiophene-Based Organic Field-Effect Transistors]. BenchChem, [2026]. [Online PDF]. Available at: [<https://www.benchchem.com/product/b050212/docs#a-comparative-benchmarking-guide-to-3-alkoxythiophene-based-organic-field-effect-transistors>]

---

### Disclaimer & Data Validity:

The information provided in this document is for Research Use Only (RUO) and is strictly not intended for diagnostic or therapeutic procedures. While BenchChem strives to provide accurate protocols, we make no warranties, express or implied, regarding the fitness of this product for every specific experimental setup.

**Technical Support:** The protocols provided are for reference purposes. Unsure if this reagent suits your experiment?

**Need Industrial/Bulk Grade?** [Request Custom Synthesis Quote](#)

## BenchChem

Our mission is to be the trusted global source of essential and advanced chemicals, empowering scientists and researchers to drive progress in science and industry.

### Contact

Address: 3281 E Guasti Rd  
Ontario, CA 91761, United States  
Phone: (601) 213-4426  
Email: [info@benchchem.com](mailto:info@benchchem.com)

[Contact our Ph.D. Support Team for a compatibility check](#)