

Technical Support Center: Characterization of Sulfonated Purines

Author: BenchChem Technical Support Team. **Date:** April 2026

Compound of Interest

Compound Name: 6-Amino-9H-purine-8-sulfonic acid

CAS No.: 696638-47-8

Cat. No.: B494949

[Get Quote](#)

Welcome to the Technical Support Center. Sulfonated purines—often encountered as phase II metabolites or synthetic drug candidates—present a unique "triple threat" of analytical challenges: extreme hydrophilicity, chemical instability, and high susceptibility to in-source fragmentation during mass spectrometry.

This guide provides field-proven, self-validating protocols to troubleshoot your LC-MS/MS workflows. Rather than just giving you a recipe, we will explore the causality behind why these molecules behave the way they do, empowering you to optimize your specific assays.

Section 1: Chromatographic Retention & Separation FAQ: Why do my sulfonated purines elute in the void volume on a standard C18 column?

The Causality: Standard reversed-phase (RP) C18 columns rely entirely on hydrophobic partitioning. Sulfonated purines bear a permanent negative charge from the sulfonate ($-\text{SO}_3\text{H}$) or sulfate ($-\text{OSO}_3\text{H}$) moiety at physiological pH, resulting in a highly negative LogP. Because they are surrounded by a dense hydration shell, they are actively repelled by the hydrophobic stationary phase and wash straight through the column into the void volume.

The Solution: To resolve this, you must shift the retention mechanism from hydrophobic partitioning to hydrophilic partitioning and electrostatic interaction. [1\[1\]](#). Specifically, zwitterionic HILIC (ZIC-HILIC) stationary phases maintain a strict 1:1 ratio of positive and negative charges.[2\[2\]](#).

Table 1: Quantitative Comparison of Chromatographic Modes for Sulfonated Purines

Parameter	Standard C18 RP-LC	Ion-Pairing RP-LC (IP-RPLC)	Zwitterionic HILIC (ZIC-HILIC)
Retention Factor (k')	< 0.5 (Void volume)	2.0 - 5.0	3.0 - 10.0
Mobile Phase	Water/Acetonitrile (0.1% FA)	Water/MeOH + Hexylamine	Acetonitrile/Water (Ammonium Acetate)
MS Compatibility	Excellent	Poor (Severe ion suppression)	Excellent (Volatile buffers used)
Peak Shape	Poor (Tailing/Split peaks)	Good	Excellent (Sharp, symmetrical)

Protocol 1: Step-by-Step ZIC-HILIC LC-MS/MS Methodology

1. Sample Preparation: Extract samples using cold (-20°C) 80% acetonitrile/water. This precipitates proteins while keeping the highly polar sulfonated purines in solution. Crucial: Avoid acidic extraction buffers (e.g., Trichloroacetic acid) as low pH catalyzes the rapid hydrolysis of the sulfate group. 2. Column Setup: Equip the LC system with a ZIC-HILIC or ZIC-cHILIC column (e.g., 150 x 2.1 mm, 3.5 µm). 3. Mobile Phase Preparation:

- Mobile Phase A: 100% Acetonitrile.
- Mobile Phase B: 20 mM Ammonium Acetate in Water, adjusted to pH 6.8. (Do not use Formic Acid; low pH suppresses the ionization efficiency of sulfates in negative mode).
- 4. Gradient Elution: Start at 85% A (highly organic to promote hydrophilic partitioning into the stationary phase's water layer). Over 15 minutes, decrease A to 40% (increasing aqueous content to elute the strongly retained sulfonated purines).
- 5. Self-Validation Check: Inject a

void volume marker (e.g., uracil). Your sulfonated purine must elute at least 2 minutes after the uracil peak to confirm true hydrophilic partitioning, rather than non-specific secondary interactions.

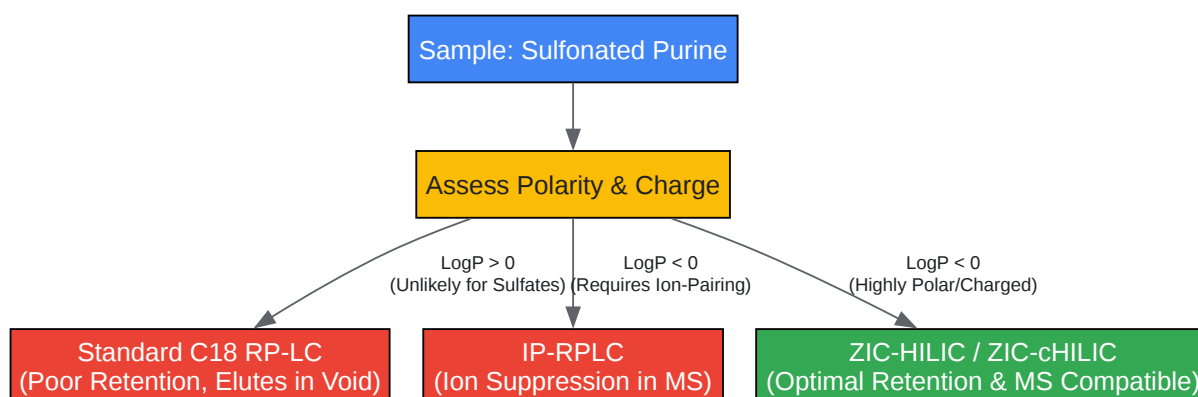

[Click to download full resolution via product page](#)

Workflow for selecting the optimal chromatographic mode for sulfonated purines.

Section 2: Mass Spectrometry & Structural Elucidation

FAQ: Why am I only seeing the unsulfonated purine mass in my MS spectra?

The Causality: This is a classic case of in-source fragmentation. The ester bond of a sulfate group (C-O-S) or the C-S bond of a sulfonate is highly labile.^{3[3].4[4]} Consequently, the mass spectrometer falsely detects the precursor as the unsulfonated purine, leading to inaccurate quantification.

The Solution: Soft ionization tuning is mandatory. You must systematically lower the cone voltage to preserve the intact precursor ion, followed by targeted Collision-Induced Dissociation (CID) in the collision cell to confirm the presence of the sulfate group.

Protocol 2: Self-Validating MS/MS Optimization for Labile Sulfates

1. Direct Infusion: Bypass the LC column and infuse a standard of your sulfonated purine (or a structural analog) at 10 $\mu\text{L}/\text{min}$ directly into the ESI source. 2. ESI Negative Mode: Operate strictly in negative electrospray ionization (ESI-) mode. Sulfonated compounds readily yield stable $[\text{M}-\text{H}]^-$ ions. 3. Self-Validating Cone Voltage Titration: Start with a very low cone voltage (e.g., 10V). Monitor the intact $[\text{M}-\text{H}]^-$ precursor. Gradually increase the voltage by 5V increments until the $[\text{M}-\text{H}-80]^-$ fragment appears in the MS1 spectrum. Set your final method cone voltage exactly 5V below this fragmentation threshold to ensure 100% precursor survival. 4. Collision-Induced Dissociation (CID): In the collision cell, apply argon gas and ramp the collision energy.⁵⁶

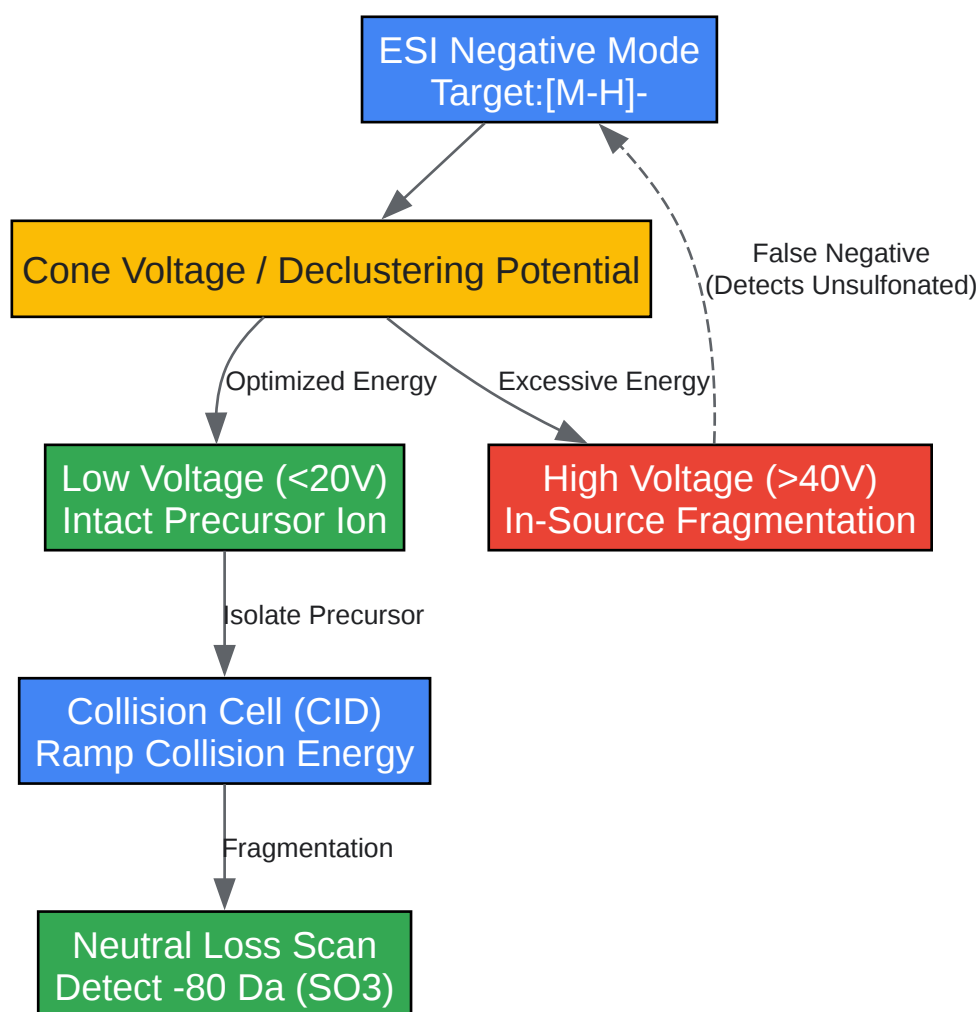

[Click to download full resolution via product page](#)

Logical relationship of ESI-MS/MS tuning to prevent in-source fragmentation.

References

- Hydrophilic interaction liquid chromatography (HILIC)
- Analysis of Nucleotide Pools in Bacteria Using HPLC-MS in HILIC Mode. bioRxiv.
- Fragment
- In-source fragment
- A Novel Method for Identification and Quantification of Sulfated Flavonoids in Plants by Neutral Loss Scan Mass Spectrometry. Frontiers.
- Ion fragmentation of small molecules in mass spectrometry. UAB.

Need Custom Synthesis?

BenchChem offers custom synthesis for rare earth carbides and specific isotopic labeling.

Email: info@benchchem.com or [Request Quote Online](#).

Sources

- 1. Hydrophilic interaction liquid chromatography (HILIC)—a powerful separation technique - PMC [[pmc.ncbi.nlm.nih.gov](https://pubmed.ncbi.nlm.nih.gov/)]
- 2. [biorxiv.org](https://www.biorxiv.org/) [[biorxiv.org](https://www.biorxiv.org/)]
- 3. Fragmentation (mass spectrometry) - Wikipedia [en.wikipedia.org]
- 4. In-source fragmentation [[jeolusa.com](https://www.jeolusa.com/)]
- 5. Frontiers | A Novel Method for Identification and Quantification of Sulfated Flavonoids in Plants by Neutral Loss Scan Mass Spectrometry [[frontiersin.org](https://www.frontiersin.org/)]
- 6. [bpb-us-w2.wpmucdn.com](https://www.bpb-us-w2.wpmucdn.com/) [[bpb-us-w2.wpmucdn.com](https://www.bpb-us-w2.wpmucdn.com/)]
- To cite this document: BenchChem. [Technical Support Center: Characterization of Sulfonated Purines]. BenchChem, [2026]. [Online PDF]. Available at: [<https://www.benchchem.com/product/b494949/docs#technical-support-center-characterization-of-sulfonated-purines>]

Disclaimer & Data Validity:

The information provided in this document is for Research Use Only (RUO) and is strictly not intended for diagnostic or therapeutic procedures. While BenchChem strives to provide accurate protocols, we make no warranties, express or implied, regarding the fitness of this product for every specific experimental setup.

Technical Support: The protocols provided are for reference purposes. Unsure if this reagent suits your experiment?

Need Industrial/Bulk Grade? [Request Custom Synthesis Quote](#)

BenchChem

Our mission is to be the trusted global source of essential and advanced chemicals, empowering scientists and researchers to drive progress in science and industry.

Contact

Address: 3281 E Guasti Rd
Ontario, CA 91761, United States
Phone: (601) 213-4426
Email: info@benchchem.com

[Contact our Ph.D. Support Team for a compatibility check](#)