

(aS)-PH-797804 p38 alpha/beta selectivity

Author: BenchChem Technical Support Team. **Date:** December 2025

Compound of Interest

Compound Name: (aS)-PH-797804

Cat. No.: B049361

[Get Quote](#)

An In-Depth Technical Guide to the p38 α /p38 β Selectivity of **(aS)-PH-797804**

Introduction

The p38 mitogen-activated protein kinases (MAPKs) are a family of serine/threonine kinases that play a central role in cellular responses to inflammatory cytokines and environmental stress.[1] Four isoforms have been identified—p38 α (MAPK14), p38 β (MAPK11), p38 γ (MAPK12), and p38 δ (MAPK13)—which are activated by upstream kinases MKK3 and MKK6 through dual phosphorylation on a conserved Thr-Gly-Tyr (TGY) motif.[1][2][3] Of these, the p38 α and p38 β isoforms are the most closely related and are widely expressed in various tissues.[2][4] They are key regulators of inflammatory pathways, primarily through their role in the production of cytokines like tumor necrosis factor-alpha (TNF- α) and interleukin-6 (IL-6).[5] [6]

While both isoforms share significant homology, they can have distinct and sometimes opposing biological functions. For instance, p38 α activation is strongly linked to pro-inflammatory and apoptotic processes, whereas p38 β has been implicated in pro-survival roles. [7][8] This functional divergence makes the development of isoform-selective inhibitors a critical goal for therapeutic intervention in inflammatory diseases, allowing for targeted modulation of the pathway while minimizing potential off-target effects.

(aS)-PH-797804 is a potent, orally active N-phenyl pyridinone inhibitor of p38 MAPK that demonstrates selectivity for the p38 α and p38 β isoforms.[9][10][11] It is the (aS)-atropisomer, which is over 100-fold more potent than its corresponding (aR)-atropisomer.[10][12] This technical guide provides a detailed overview of the p38 α /p38 β selectivity profile of **(aS)-PH-**

797804, presenting key quantitative data, the experimental protocols used for its characterization, and visualizations of the relevant biological pathways and experimental workflows.

Quantitative Selectivity Data

The inhibitory activity of **(aS)-PH-797804** has been quantified against p38 isoforms and a panel of other kinases to establish its selectivity profile. The data are summarized below.

Table 1: p38 Isoform Inhibition Profile of (aS)-PH-797804

Target	Parameter	Value (nM)	Reference
p38 α	IC ₅₀	26	[6][9][12][13]
p38 β	IC ₅₀	102	[6][12][13]
p38 α	K _i	5.8	[5]
p38 β	K _i	40	[5]

IC₅₀: Half-maximal inhibitory concentration. K_i: Inhibition constant.

Based on IC₅₀ values, **(aS)-PH-797804** is approximately 4-fold more selective for p38 α over p38 β . [6][9]

Table 2: Selectivity of (aS)-PH-797804 Against Other Kinases

(aS)-PH-797804 exhibits a high degree of selectivity for p38 α/β over other related and unrelated kinases. [12][14]

Kinase Target	IC ₅₀ (μM)
JNK2	No inhibition noted
ERK2	>200
CDK2	>200
IKK1	>200
IKK2	>200
MAPKAP2	>200
MKK7	>100

Data compiled from multiple sources.[\[5\]](#)[\[6\]](#)[\[9\]](#)

Experimental Protocols

The selectivity of **(aS)-PH-797804** was determined using a biochemical kinase assay designed to measure the phosphorylation of a substrate by p38 kinases.

p38 Kinase Inhibition Assay (Resin Capture Method)

This assay quantifies the transfer of a radiolabeled phosphate group from [γ -³³P]ATP to a peptide substrate by the p38 kinase.

1. Reagents and Materials:

- Enzyme: Recombinant human p38 α or p38 β kinase (e.g., 25 nM final concentration).[\[9\]](#)
- Substrate: Epidermal Growth Factor Receptor Peptide (EGFRP) at 200 μM or GST-c-Jun at 10 μM.[\[6\]](#)[\[9\]](#)
- ATP: A mixture of non-labeled ATP and [γ -³³P]ATP (0.05 to 0.3 μCi).[\[6\]](#)[\[9\]](#)
- Assay Buffer (pH 7.5): 25 mM HEPES, 10 mM magnesium acetate, 0.8 mM dithiothreitol (DTT).[\[6\]](#)[\[9\]](#)
- Test Compound: **(aS)-PH-797804** serially diluted in DMSO.

- Stop Reagent: AG 1 × 8 ion exchange resin in 900 mM sodium formate (pH 3.0).[9]
- Scintillation Cocktail: MicroScint-40 or similar.[9]
- Hardware: 96-well plates, microplate scintillation counter (e.g., TopCount NXT).[9]

2. Assay Procedure:

- The test compound, **(aS)-PH-797804**, is pre-incubated with the p38 α or p38 β kinase in the assay buffer.
- The kinase reaction is initiated by adding the substrate (EGFRP or GST-c-Jun) and the ATP/[γ -³³P]ATP mixture to the enzyme-inhibitor solution. The final reaction volume is 50 μ L.[9]
- The reaction mixtures are incubated for 30 minutes at 25°C, a timeframe within which product formation is linear.[9]
- The reaction is terminated by the addition of 150 μ L of the AG 1 × 8 ion exchange resin slurry. This resin binds and removes the unreacted, negatively charged [γ -³³P]ATP.[9]
- After mixing and allowing the resin to settle for 5 minutes, a 50 μ L aliquot of the supernatant, which contains the now-phosphorylated and positively charged substrate, is transferred to a new 96-well plate.[9]
- 150 μ L of scintillation cocktail is added to each well.[9]
- The amount of incorporated ³³P is quantified by measuring radioactivity using a microplate scintillation counter.[9]
- IC₅₀ values are calculated by plotting the percentage of inhibition against the logarithm of the inhibitor concentration.

Visualizations: Pathways and Workflows

p38 MAPK Signaling Pathway

The following diagram illustrates the canonical p38 MAPK signaling cascade, initiated by stress signals and culminating in the activation of downstream kinases and transcription factors.

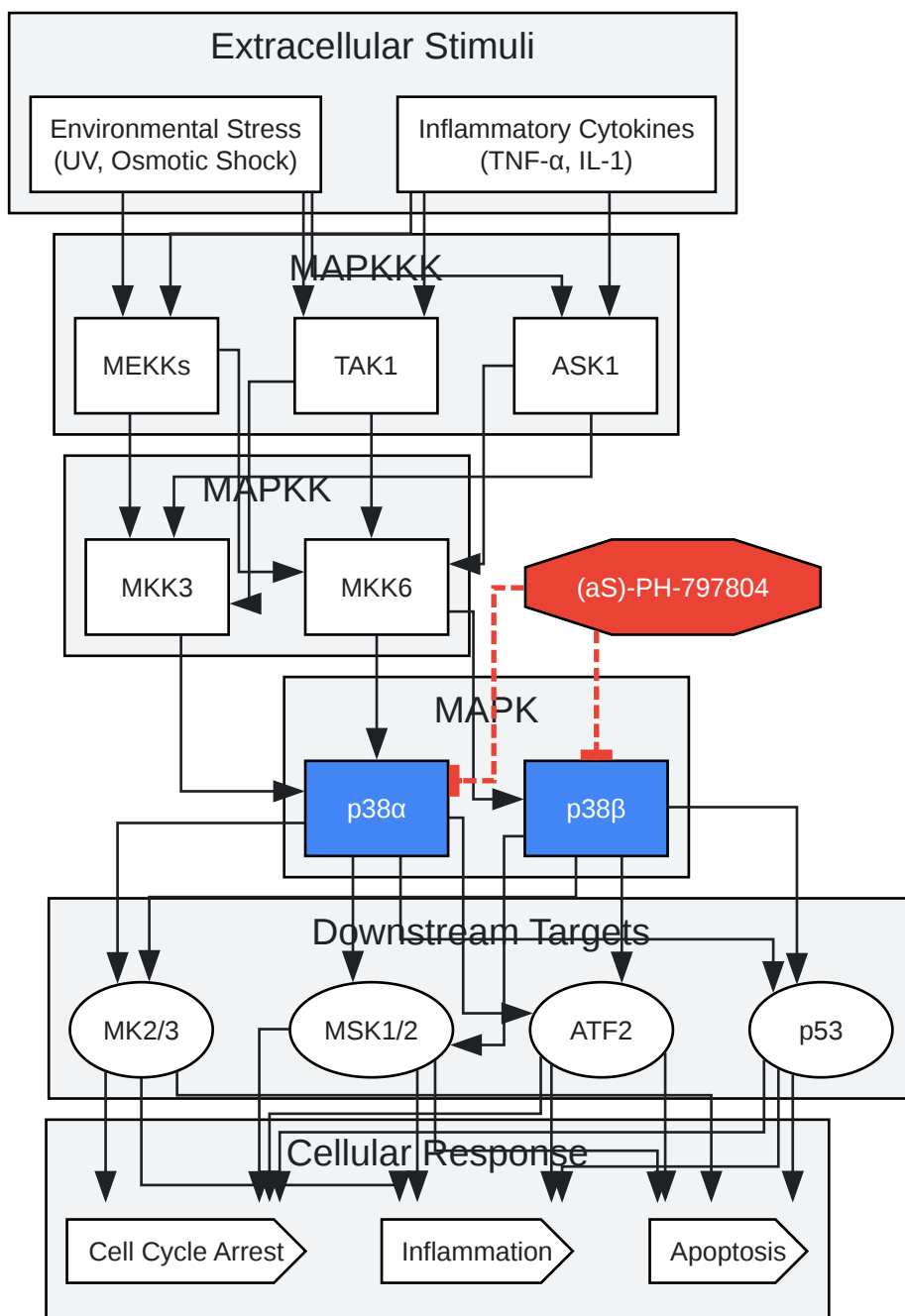

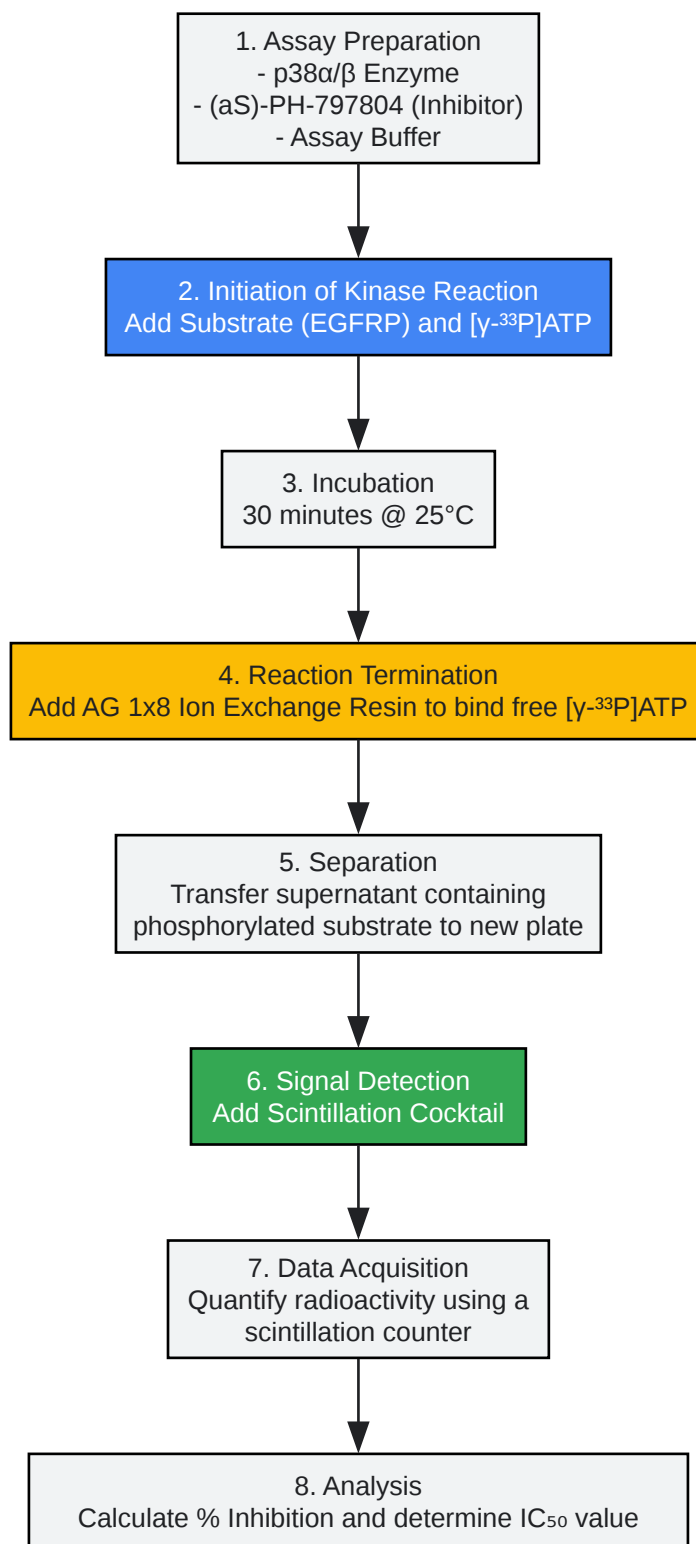

[Click to download full resolution via product page](#)

Need Custom Synthesis?

BenchChem offers custom synthesis for rare earth carbides and specific isotopic labeling.

Email: info@benchchem.com or [Request Quote Online](#).

References

- 1. p38 mitogen-activated protein kinases - Wikipedia [en.wikipedia.org]
- 2. creative-diagnostics.com [creative-diagnostics.com]
- 3. sigmaaldrich.com [sigmaaldrich.com]
- 4. p38 MAPK α and β isoforms differentially regulate plasma membrane localization of MRP2 - PMC [pmc.ncbi.nlm.nih.gov]
- 5. medchemexpress.com [medchemexpress.com]
- 6. PH-797804 | p38 MAPK | Autophagy | TargetMol [targetmol.com]
- 7. The activation of p38alpha, and not p38beta, mitogen-activated protein kinase is required for ischemic preconditioning - PMC [pmc.ncbi.nlm.nih.gov]
- 8. MAPK14 - Wikipedia [en.wikipedia.org]
- 9. selleckchem.com [selleckchem.com]
- 10. Discovery and characterization of atropisomer PH-797804, a p38 MAP kinase inhibitor, as a clinical drug candidate - PubMed [pubmed.ncbi.nlm.nih.gov]
- 11. Discovery of PH-797804, a highly selective and potent inhibitor of p38 MAP kinase - PubMed [pubmed.ncbi.nlm.nih.gov]
- 12. PH 797804 | p38 MAPK | Tocris Bioscience [tocris.com]
- 13. medchemexpress.com [medchemexpress.com]
- 14. pubs.acs.org [pubs.acs.org]
- To cite this document: BenchChem. [(aS)-PH-797804 p38 alpha/beta selectivity]. BenchChem, [2025]. [Online PDF]. Available at: [https://www.benchchem.com/product/b049361#as-ph-797804-p38-alpha-beta-selectivity]

Disclaimer & Data Validity:

The information provided in this document is for Research Use Only (RUO) and is strictly not intended for diagnostic or therapeutic procedures. While BenchChem strives to provide accurate protocols, we make no warranties, express or implied, regarding the fitness of this product for every specific experimental setup.

Technical Support: The protocols provided are for reference purposes. Unsure if this reagent suits your experiment? [[Contact our Ph.D. Support Team for a compatibility check](#)]

Need Industrial/Bulk Grade? [Request Custom Synthesis Quote](#)

BenchChem

Our mission is to be the trusted global source of essential and advanced chemicals, empowering scientists and researchers to drive progress in science and industry.

Contact

Address: 3281 E Guasti Rd
Ontario, CA 91761, United States
Phone: (601) 213-4426
Email: info@benchchem.com