

Technical Support Center: PBFI-AM

Troubleshooting

Author: BenchChem Technical Support Team. **Date:** December 2025

Compound of Interest

Compound Name: *Pbfi-AM*

Cat. No.: *B049554*

[Get Quote](#)

This guide provides solutions to common issues encountered during intracellular potassium ($[K^+]$) measurements using **PBFI-AM**.

Frequently Asked Questions (FAQs)

Q1: Why is my PBFI-AM fluorescence signal weak or absent?

A weak or non-existent signal is a common issue that can stem from several factors, including poor dye loading, incomplete hydrolysis of the AM ester, or instrument settings.

Troubleshooting Steps:

- **Incomplete Hydrolysis:** The acetoxymethyl (AM) ester form of PBFI is not fluorescent and must be cleaved by intracellular esterases to become active.^[1] Low esterase activity in certain cell types can lead to inefficient dye activation.
 - **Solution:** Increase the incubation time to allow for more complete hydrolysis. Ensure the loading buffer is at a physiological pH (7.2-7.4), as esterase activity is pH-sensitive.^[2]
- **Poor Dye Loading:** **PBFI-AM** may not efficiently cross the cell membrane.
 - **Solution:** Optimize the loading concentration and time for your specific cell type.^[2] The use of a non-ionic surfactant like Pluronic F-127 can aid in the dispersion of the nonpolar AM ester in aqueous loading buffers, improving loading efficiency.^[2]

- Incorrect Filter Sets: PBFI is a ratiometric, UV-excitabile dye. Using incorrect filters will result in poor signal.
 - Solution: Use standard Fura-2 filter sets. For measuring K⁺-bound PBFI, use an excitation of ~340 nm, and for K⁺-free PBFI, use an excitation of ~380 nm.[3] Emission should be collected at ~500-505 nm.

Q2: My fluorescence signal is bright initially but then fades rapidly. What is causing this quenching and how can I prevent it?

This phenomenon is typically due to photobleaching or dye leakage from the cells.

Troubleshooting Steps:

- Photobleaching: The fluorophore can be irreversibly damaged by prolonged or high-intensity excitation light.
 - Prevention:
 - Reduce the intensity of the excitation light.
 - Decrease the duration of light exposure by using the shortest possible exposure times.
 - Use a neutral density filter to attenuate the excitation light.
 - Acquire images less frequently.
 - The ratiometric nature of PBFI helps to reduce the effects of photobleaching on quantification.
- Dye Leakage: The hydrolyzed, active form of PBFI is an anion that can be actively transported out of the cell by organic anion transporters.
 - Prevention:

- Lower the incubation temperature during the experiment (e.g., perform imaging at room temperature instead of 37°C).
- Incorporate an organic anion transport inhibitor, such as probenecid, into the loading and imaging buffers.

Q3: My results are inconsistent, and the dye appears to be compartmentalized. How can I fix this?

Uneven dye loading and compartmentalization within organelles can lead to unreliable and non-uniform fluorescence signals.

Troubleshooting Steps:

- Aggregation of Dye: **PBFI-AM** can aggregate in aqueous solutions, leading to uneven loading.
 - Solution: Ensure the **PBFI-AM** stock solution in DMSO is well-vortexed. When preparing the loading solution, add the dye to the buffer while vortexing to promote even dispersion. The use of Pluronic F-127 is highly recommended to prevent aggregation.
- Compartmentalization: The dye can accumulate in organelles like mitochondria, leading to a non-cytosolic signal.
 - Solution: Lower the loading temperature (e.g., from 37°C to room temperature) and decrease the dye concentration. This can reduce the active uptake of the dye into organelles.

Experimental Protocols & Data

Optimized **PBFI-AM** Loading Protocol

This protocol provides a general guideline. Conditions such as dye concentration, temperature, and time should be optimized for your specific cell type and experimental setup.

- Reagent Preparation:
 - Prepare a 1-5 mM stock solution of **PBFI-AM** in high-quality, anhydrous DMSO.

- Prepare a 10% (w/v) stock solution of Pluronic F-127 in DMSO.
- Prepare a 100X stock solution of Probenecid in a suitable buffer (optional, for preventing leakage).
- Loading Solution Preparation:
 - Begin with your preferred assay buffer (e.g., HEPES-buffered Hank's Balanced Salt Solution, pH 7.2-7.4).
 - Add Pluronic F-127 to the buffer to a final concentration of 0.01-0.04%.
 - If using, add Probenecid to its final working concentration.
 - Add the **PBFI-AM** stock solution to the buffer to achieve a final concentration in the range of 5-20 μ M. Vortex the solution immediately after adding the dye to ensure it is evenly dispersed.
- Cell Loading:
 - Remove the cell culture medium from your adherent cells or pellet your suspension cells.
 - Add the dye loading solution to the cells.
 - Incubate at 37°C for 30-60 minutes.
- Washing:
 - Remove the loading solution.
 - Wash the cells 2-3 times with fresh, warm assay buffer (containing probenecid, if used) to remove any extracellular dye.
 - Incubate the cells for an additional 30 minutes to allow for complete de-esterification of the dye.
- Imaging:

- Proceed with fluorescence imaging, alternating excitation between ~340 nm and ~380 nm while collecting emission at ~500 nm.

Troubleshooting Summary Table

Issue	Potential Cause	Recommended Solution
Weak/No Signal	Incomplete hydrolysis of AM ester	Increase incubation time; ensure physiological pH (7.2-7.4).
Poor dye loading	Optimize dye concentration and incubation time; use Pluronic F-127.	
Incorrect instrument settings	Use filters for UV excitation (~340/380 nm) and green emission (~500 nm).	
Signal Fades Rapidly	Photobleaching	Reduce excitation light intensity/duration; acquire images less frequently.
Dye leakage	Lower imaging temperature; add an anion transport inhibitor like probenecid.	
Inconsistent Results	Dye aggregation	Vortex during loading solution preparation; use Pluronic F-127.
Dye compartmentalization	Lower loading temperature and concentration.	

Visual Guides

PBFI-AM Cellular Workflow and Quenching Pathways

This diagram illustrates the process of **PBFI-AM** entering the cell, its activation, and the common pathways that lead to signal quenching.

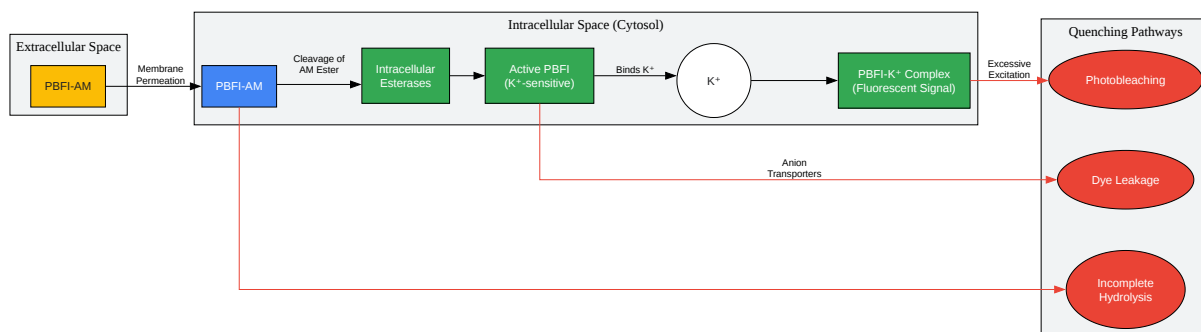

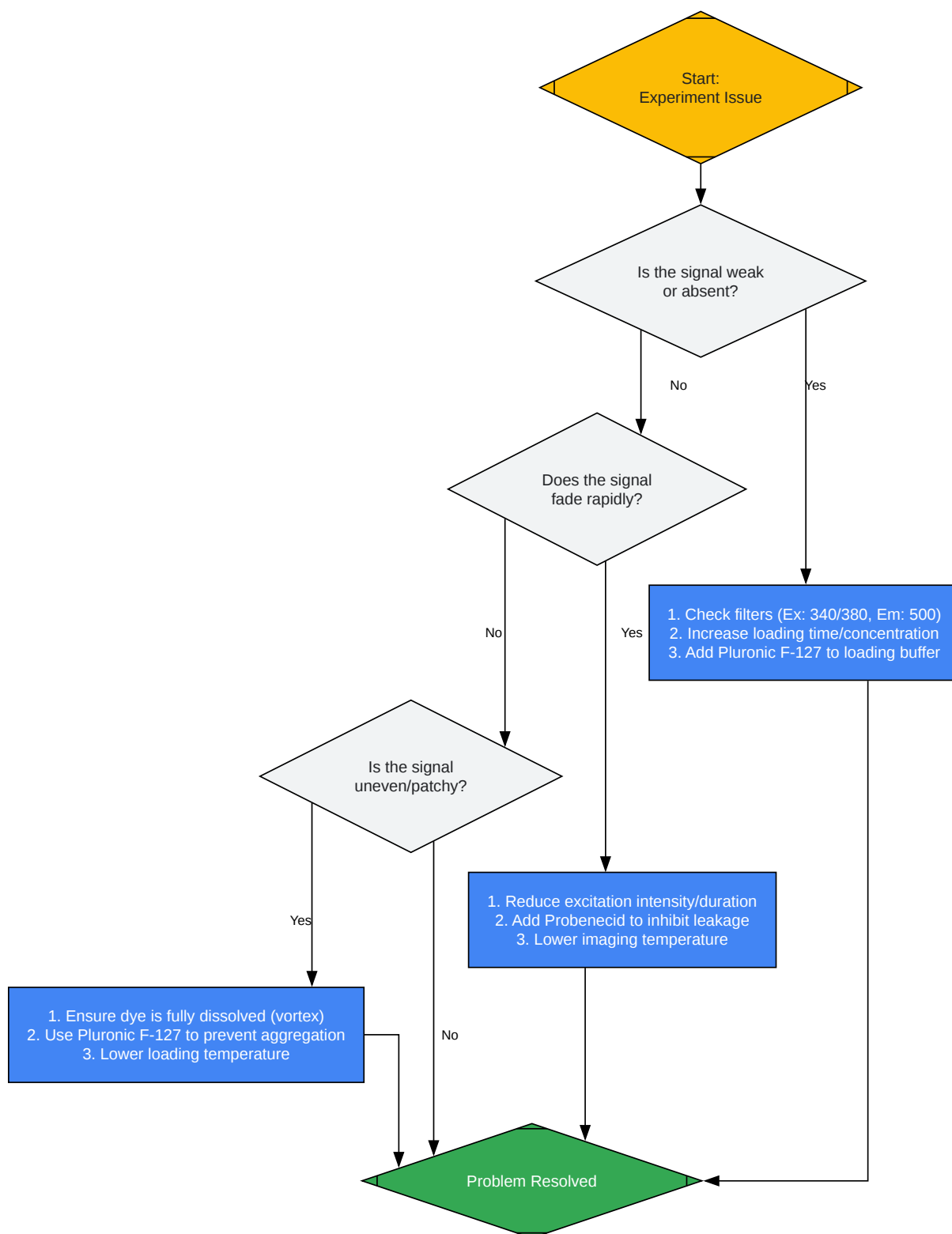

[Click to download full resolution via product page](#)

Need Custom Synthesis?

BenchChem offers custom synthesis for rare earth carbides and specific isotopic labeling.

Email: info@benchchem.com or [Request Quote Online](#).

References

- 1. PBF1 AM, fluorescent K+ binding probe (CAS 124549-23-1) | Abcam [abcam.com]
- 2. ionbiosciences.com [ionbiosciences.com]
- 3. ionbiosciences.com [ionbiosciences.com]
- To cite this document: BenchChem. [Technical Support Center: PBF1-AM Troubleshooting]. BenchChem, [2025]. [Online PDF]. Available at: [<https://www.benchchem.com/product/b049554#pbf1-am-quenching-and-how-to-prevent-it>]

Disclaimer & Data Validity:

The information provided in this document is for Research Use Only (RUO) and is strictly not intended for diagnostic or therapeutic procedures. While BenchChem strives to provide accurate protocols, we make no warranties, express or implied, regarding the fitness of this product for every specific experimental setup.

Technical Support: The protocols provided are for reference purposes. Unsure if this reagent suits your experiment? [[Contact our Ph.D. Support Team for a compatibility check](#)]

Need Industrial/Bulk Grade? [Request Custom Synthesis Quote](#)

BenchChem

Our mission is to be the trusted global source of essential and advanced chemicals, empowering scientists and researchers to drive progress in science and industry.

Contact

Address: 3281 E Guasti Rd

Ontario, CA 91761, United States

Phone: (601) 213-4426

Email: info@benchchem.com