

A Comparative Guide to Androgen Synthesis Inhibitors for Prostate Cancer Research

Author: BenchChem Technical Support Team. **Date:** January 2026

Compound of Interest

Compound Name: *Biriperone*

Cat. No.: *B048065*

[Get Quote](#)

Introduction

Androgen synthesis inhibitors represent a cornerstone in the treatment of advanced prostate cancer, particularly in the castration-resistant setting (CRPC). These agents function by disrupting the production of androgens, the male hormones that fuel prostate cancer growth. While the prompt for this guide specified a comparison involving **Biriperone**, an extensive search of the scientific literature and clinical trial databases did not yield any information on a compound by this name within the context of androgen synthesis inhibition. Therefore, this guide has been developed to provide a comprehensive comparison of key and novel androgen synthesis inhibitors that are central to current research and clinical practice: Abiraterone, Orteronel, Galeterone, and Seviteronel.

This document is intended for researchers, scientists, and drug development professionals. It will delve into the mechanisms of action, comparative efficacy based on experimental data, and the methodologies used to evaluate these potent therapeutic agents.

The Landscape of Androgen Synthesis Inhibition

The primary target for this class of drugs is the enzyme Cytochrome P450 17A1 (CYP17A1). This enzyme is a critical chokepoint in the steroidogenesis pathway, catalyzing two essential reactions: 17 α -hydroxylase and 17,20-lyase activities.[1] By inhibiting CYP17A1, these drugs effectively shut down the production of androgens, not only in the testes but also in the adrenal glands and within the tumor microenvironment itself.[2][3] This comprehensive blockade is vital in treating CRPC, where tumors often develop mechanisms to produce their own androgens.[3]

Mechanism of Action: Targeting CYP17A1

The androgen biosynthesis pathway is a complex cascade of enzymatic reactions that convert cholesterol into various steroid hormones. CYP17A1's dual enzymatic function makes it a highly attractive target for therapeutic intervention in prostate cancer.

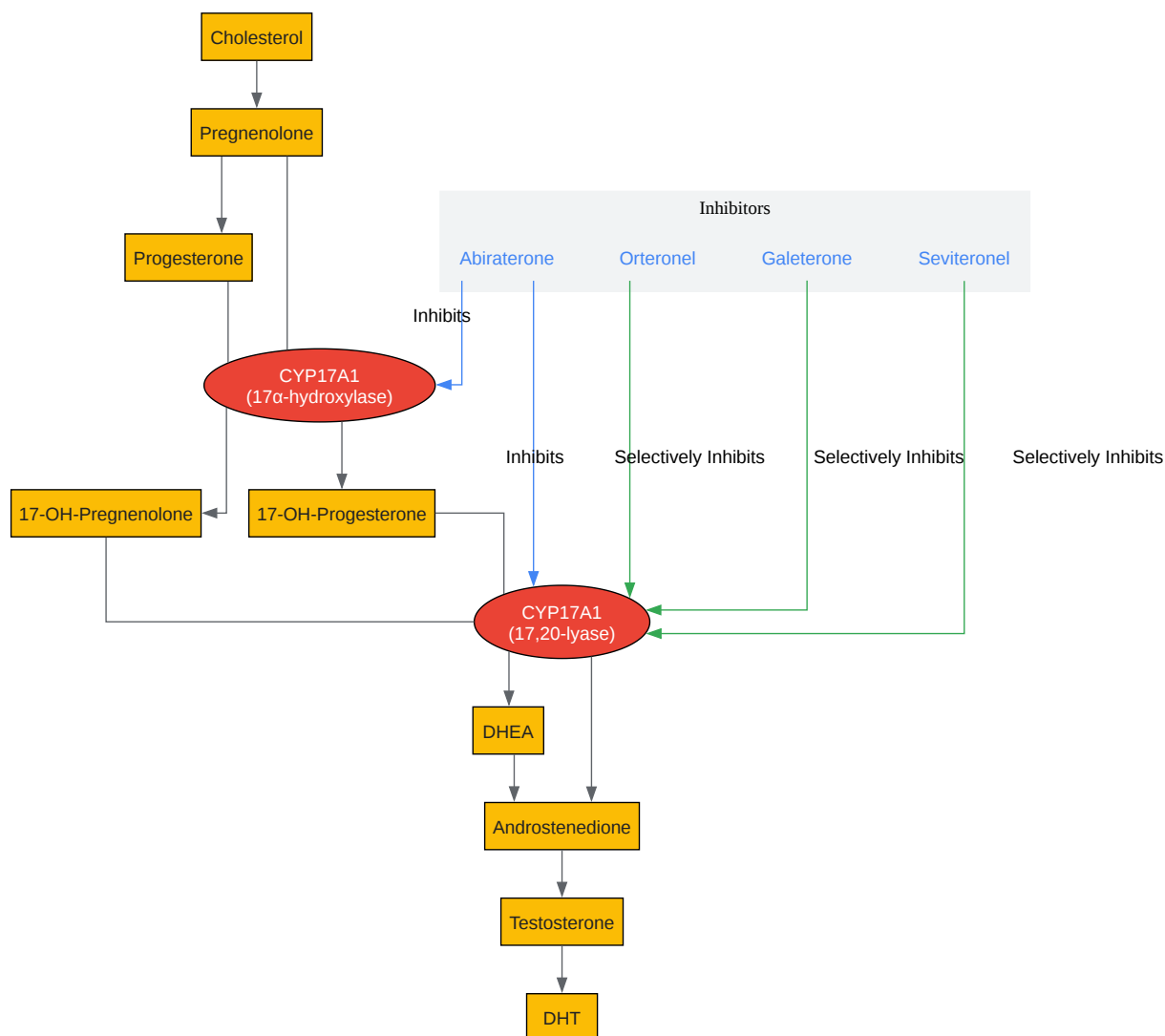

[Click to download full resolution via product page](#)

Figure 1: Androgen Biosynthesis Pathway and Points of Inhibition.

Comparative Analysis of Leading Androgen Synthesis Inhibitors

A critical aspect of drug development is understanding the nuances that differentiate compounds within the same class. For androgen synthesis inhibitors, these differences lie in their potency, selectivity for the 17,20-lyase versus the 17 α -hydroxylase activity of CYP17A1, and their off-target effects.

Compound	Target	IC50 (17 α -hydroxylase)	IC50 (17,20-lyase)	Selectivity (lyase/hydroxylase)	Key Characteristics
Abiraterone	CYP17A1	15 nM ^[1]	2.5 nM ^[1]	~0.17	Irreversible inhibitor of both hydroxylase and lyase activities. ^[4] Requires co-administration with prednisone to manage side effects from mineralocorticoid excess. ^[5]
Orteronel (TAK-700)	CYP17A1	348 nM	64 nM	~5.4	Non-steroidal, selective inhibitor of 17,20-lyase. ^[6] Designed to minimize mineralocorticoid-related side effects.

Galeterone (TOK-001)	CYP17A1, AR	73 nM	23 nM	~3.2	In addition to CYP17A1 inhibition, it also exhibits androgen receptor (AR) antagonist activity.[6]
Seviteronel (VT-464)	CYP17A1, AR	670 nM	69 nM	~9.7	Selective 17,20-lyase inhibitor with direct AR antagonist effects.[6]

Abiraterone, the first-in-class CYP17A1 inhibitor, has demonstrated significant clinical efficacy in extending survival in patients with metastatic CRPC.[7] Its irreversible inhibition of both CYP17A1 activities leads to a profound suppression of androgen synthesis.[4] However, this potent inhibition also blocks cortisol production, leading to a compensatory rise in adrenocorticotrophic hormone (ACTH) and subsequent mineralocorticoid excess, necessitating the co-administration of prednisone.[5]

Orteronel, Galeterone, and Seviteronel were developed as next-generation inhibitors with improved selectivity for the 17,20-lyase activity of CYP17A1. The rationale behind this approach is to preferentially block androgen synthesis while sparing cortisol production, thereby mitigating the need for concurrent steroid therapy and its associated side effects.[6] Notably, Galeterone and Seviteronel also possess the dual mechanism of directly antagonizing the androgen receptor, which may offer an additional therapeutic advantage.[6]

Experimental Protocols for Evaluating Androgen Synthesis Inhibitors

The preclinical evaluation of novel androgen synthesis inhibitors relies on a series of robust in vitro and cell-based assays to determine their potency, selectivity, and mechanism of action.

In Vitro CYP17A1 Inhibition Assay

This assay directly measures the ability of a compound to inhibit the enzymatic activities of CYP17A1.

Objective: To determine the IC₅₀ value of a test compound against CYP17A1's 17 α -hydroxylase and 17,20-lyase activities.

Methodology:

- Enzyme Source: Recombinant human CYP17A1 co-expressed with cytochrome P450 reductase in a microsomal preparation.
- Substrates:
 - For 17 α -hydroxylase activity: Radiolabeled pregnenolone or progesterone.
 - For 17,20-lyase activity: Radiolabeled 17 α -hydroxypregnenolone.
- Incubation: The enzyme, substrate, and varying concentrations of the inhibitor are incubated in a temperature-controlled environment. The reaction is initiated by the addition of an NADPH-generating system.
- Extraction: After a defined incubation period, the reaction is stopped, and the steroids are extracted using an organic solvent.
- Analysis: The substrate and product are separated using thin-layer chromatography (TLC) or high-performance liquid chromatography (HPLC). The amount of product formed is quantified by detecting the radiolabel.
- Data Analysis: The percentage of inhibition at each inhibitor concentration is calculated relative to a vehicle control. The IC₅₀ value is then determined by fitting the data to a dose-response curve.

Causality Behind Experimental Choices: The use of radiolabeled substrates provides a highly sensitive and direct measure of enzyme activity. Separating the assays for the two distinct activities of CYP17A1 is crucial for determining the selectivity of the inhibitor, a key parameter for next-generation compounds.

Cell-Based Androgen Production Assay

This assay assesses the ability of an inhibitor to block androgen synthesis in a more physiologically relevant cellular context.

Objective: To measure the inhibition of androgen production in a steroidogenic cell line.

Methodology:

- Cell Line: Human adrenal carcinoma cell line (e.g., NCI-H295R) or prostate cancer cell lines capable of de novo steroid synthesis (e.g., LNCaP, VCaP).[\[1\]](#)
- Treatment: Cells are treated with varying concentrations of the test inhibitor for a specified period.
- Hormone Measurement: The concentration of androgens (e.g., testosterone, DHT) and other key steroid hormones in the cell culture supernatant is measured using sensitive techniques like liquid chromatography-tandem mass spectrometry (LC-MS/MS) or enzyme-linked immunosorbent assay (ELISA).
- Data Analysis: The reduction in androgen levels is quantified relative to a vehicle-treated control to determine the inhibitor's potency in a cellular system.

Causality Behind Experimental Choices: This assay provides a more integrated assessment of the inhibitor's effect, taking into account cell permeability, metabolism, and potential off-target effects within a living cell. Measuring a panel of steroid hormones can also provide valuable insights into the inhibitor's selectivity and its impact on the broader steroidogenesis pathway.

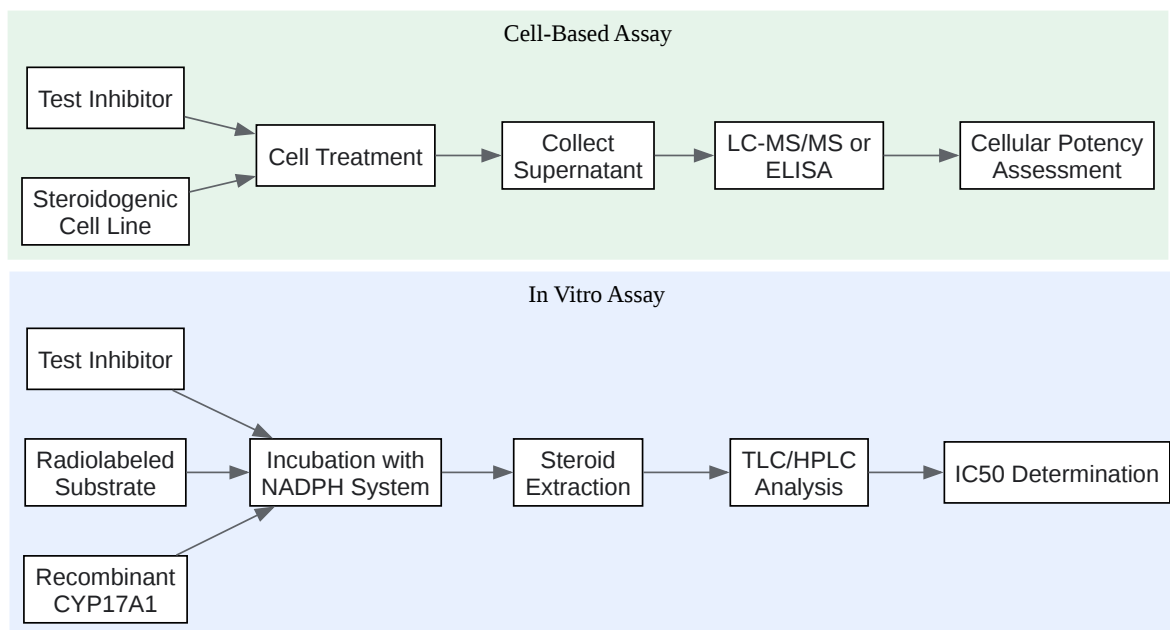

[Click to download full resolution via product page](#)

Need Custom Synthesis?

BenchChem offers custom synthesis for rare earth carbides and specific isotopic labeling.

Email: info@benchchem.com or [Request Quote Online](#).

Sources

- 1. Abiraterone in prostate cancer: a new angle to an old problem - PubMed [pubmed.ncbi.nlm.nih.gov]
- 2. Abiraterone acetate, an inhibitor of adrenal androgen synthesis in “hormone refractory prostate cancer” - PMC [pmc.ncbi.nlm.nih.gov]

- 3. Resistance to CYP17A1 inhibition with abiraterone in castration resistant prostate cancer: Induction of steroidogenesis and androgen receptor splice variants - PMC [pmc.ncbi.nlm.nih.gov]
- 4. Abiraterone: mechanism of action, pharmacokinetics and clinical applications_Chemicalbook [chemicalbook.com]
- 5. researchgate.net [researchgate.net]
- 6. icr.ac.uk [icr.ac.uk]
- 7. Clinical and biochemical consequences of CYP17A1 inhibition with abiraterone given with and without exogenous glucocorticoids in castrate men with advanced prostate cancer - PubMed [pubmed.ncbi.nlm.nih.gov]
- To cite this document: BenchChem. [A Comparative Guide to Androgen Synthesis Inhibitors for Prostate Cancer Research]. BenchChem, [2026]. [Online PDF]. Available at: [https://www.benchchem.com/product/b048065#biriperone-versus-other-androgen-synthesis-inhibitors]

Disclaimer & Data Validity:

The information provided in this document is for Research Use Only (RUO) and is strictly not intended for diagnostic or therapeutic procedures. While BenchChem strives to provide accurate protocols, we make no warranties, express or implied, regarding the fitness of this product for every specific experimental setup.

Technical Support: The protocols provided are for reference purposes. Unsure if this reagent suits your experiment? [[Contact our Ph.D. Support Team for a compatibility check](#)]

Need Industrial/Bulk Grade? [Request Custom Synthesis Quote](#)

BenchChem

Our mission is to be the trusted global source of essential and advanced chemicals, empowering scientists and researchers to drive progress in science and industry.

Contact

Address: 3281 E Guasti Rd

Ontario, CA 91761, United States

Phone: (601) 213-4426

Email: info@benchchem.com