

# Application Note: One-Pot Synthesis Methods for Benzoxazole Alkylamines

**Author:** BenchChem Technical Support Team. **Date:** May 2026

## Compound of Interest

Compound Name: *3-(1,3-benzoxazol-2-yl)-1-propanamine*

Cat. No.: *B4653395*

[Get Quote](#)

## Introduction & Strategic Significance

Benzoxazole alkylamines (specifically 2-substituted benzoxazoles bearing an aminoalkyl side chain) represent a privileged scaffold in medicinal chemistry. The benzoxazole core mimics the purine and peptide bond electronic distributions while offering improved metabolic stability.

Traditional synthesis often involves multi-step procedures: acylation of 2-aminophenol, protection/deprotection steps, and harsh cyclization conditions (e.g., polyphosphoric acid at >150°C). This guide details three advanced one-pot protocols that circumvent these bottlenecks, prioritizing atom economy, mild conditions, and scalability.

## Core Synthetic Strategies

- Oxidative Cyclization (Metal-Free): Utilizing molecular iodine ( ) to drive the condensation of aminophenols with amino-aldehydes or alcohols.
- Microwave-Assisted Condensation: Rapid coupling of 2-aminophenols with -protected amino acids.

- Multicomponent Assembly (Ugi-Variant): Leveraging isocyanide chemistry for high-diversity library generation.

## Mechanistic Pathways & Logic

Understanding the mechanism is vital for troubleshooting. The formation of the benzoxazole ring generally proceeds via a Schiff base intermediate followed by an intramolecular nucleophilic attack and oxidative aromatization.

### Figure 1: Mechanistic Pathway of Iodine-Catalyzed Cyclization

The following diagram illustrates the oxidative cyclization pathway, a dominant method for generating benzoxazoles under mild conditions.

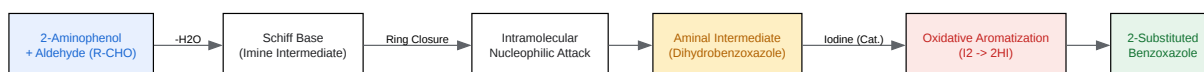

[Click to download full resolution via product page](#)

Caption: Logical flow of the iodine-catalyzed oxidative cyclization converting a Schiff base into the aromatic benzoxazole core.

## Experimental Protocols

### Protocol A: Iodine-Catalyzed Oxidative Cyclization (Metal-Free)

Best for: Synthesizing benzoxazoles from aldehydes and aminophenols under mild, aerobic conditions. Mechanism: The iodine acts as a Lewis acid to activate the imine and an oxidant to drive aromatization.

Reagents:

- 2-Aminophenol (1.0 equiv)

- Aldehyde (e.g.,  
-Boc-aminoacetaldehyde) (1.1 equiv)
- Molecular Iodine (  
) (10-20 mol%)
- Solvent: Methanol (MeOH) or Ethanol (EtOH)
- Oxidant: Hydrogen Peroxide (  
) or TBHP (optional, allows catalytic  
)

#### Step-by-Step Procedure:

- Charge: In a round-bottom flask, dissolve 2-aminophenol (1.0 mmol) and the appropriate amino-aldehyde (1.1 mmol) in MeOH (5 mL).
- Imine Formation: Stir at room temperature for 15–30 minutes. A color change (often yellowing) indicates Schiff base formation.
- Catalyst Addition: Add molecular iodine (0.1 mmol, 10 mol%). Note: If using stoichiometric iodine without external oxidant, use 1.1 equiv.
- Reaction: Stir at room temperature (or mild heat, 40°C) for 2–4 hours. Monitor by TLC (Eluent: Hexane/EtOAc 3:1). The intermediate aminal spot should disappear.
- Quench: Add saturated aqueous  
(sodium thiosulfate) to quench unreacted iodine (solution turns from dark brown to clear/yellow).
- Workup: Extract with Ethyl Acetate (3 x 10 mL). Wash combined organics with brine, dry over  
, and concentrate.
- Purification: Flash column chromatography on silica gel.

#### Validation Check:

- Self-Validating Step: The disappearance of the deep iodine color upon thiosulfate addition confirms the quenching. If the reaction mixture remains colorless during the reaction (when using catalytic  
  
) , add more oxidant (  
  
) to regenerate the active iodine species.

## Protocol B: Microwave-Assisted Condensation with Amino Acids

Best for: Direct synthesis of 2-(aminoalkyl)benzoxazoles from

-protected amino acids. This method avoids the need for unstable amino-aldehydes. Green Aspect: Solvent-free or minimal solvent; high atom economy.

#### Reagents:

- 2-Aminophenol (1.0 equiv)
- -Boc-Amino Acid (e.g., Boc-Gly-OH, Boc-Phe-OH) (1.1 equiv)
- Catalyst: Polyphosphoric Acid (PPA) or PPE (Polyphosphate Ester)
- Alternative Green Catalyst: Deep Eutectic Solvent (Choline Chloride/Oxalic Acid)[1]

#### Step-by-Step Procedure:

- Preparation: Mix 2-aminophenol (1.0 mmol) and  
  
-Boc-amino acid (1.1 mmol) in a microwave process vial.
- Catalyst: Add PPA (approx. 2-3 g) or PPE. Caution: PPA is viscous; ensure thorough mixing.
- Irradiation: Irradiate at 100–120°C for 10–20 minutes (Power: 150W, Max Pressure: 200 psi).
- Neutralization: Pour the hot reaction mixture slowly into crushed ice/water containing

- . Critical Safety Step: Exothermic neutralization.
- Extraction: Extract the precipitate or oil with DCM (Dichloromethane).
- Deprotection (Optional One-Pot Extension): If the Boc group is cleaved by the thermal acidic conditions (common with PPA), the free amine is obtained directly. If retention of Boc is desired, use milder coupling agents like T3P (Propylphosphonic anhydride) in EtOAc before cyclization.

## Figure 2: Microwave Synthesis Workflow

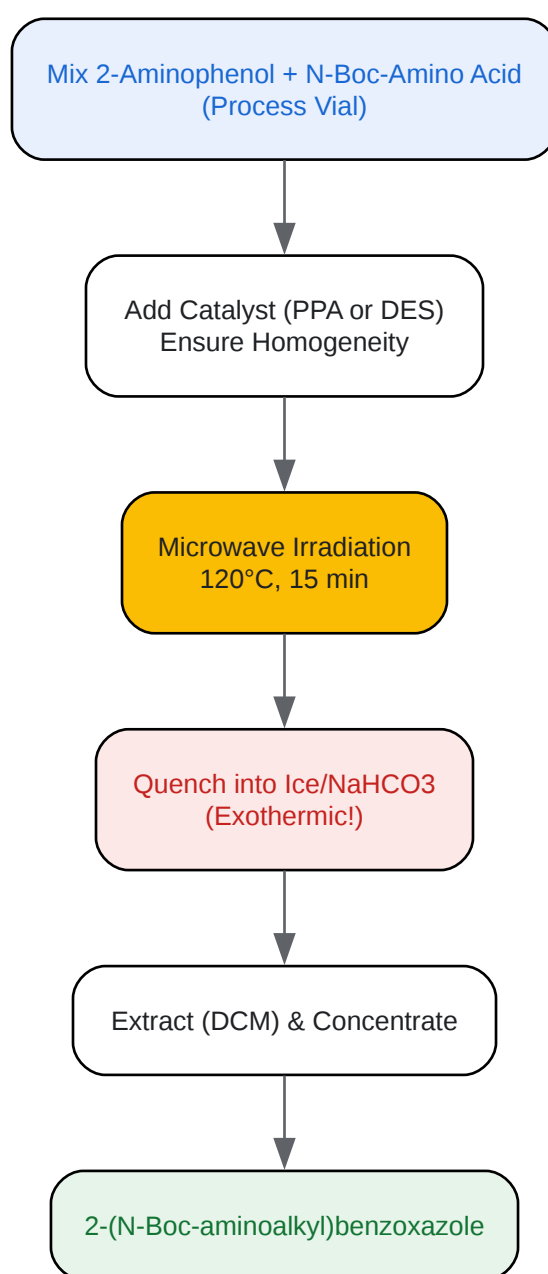

[Click to download full resolution via product page](#)

Caption: Streamlined workflow for the microwave-assisted synthesis of benzoxazole alkylamines.

## Data Summary & Optimization

The following table summarizes typical yields and conditions for the synthesis of 2-substituted benzoxazoles using these protocols.

Entry	Substrate (R-Group)	Method	Catalyst/ Reagent	Time	Yield (%)	Ref
1	2-(Aminomethyl)	Protocol A	(10 mol%) /	3 h	85-92	[1, 2]
2	2-(1-Aminoethyl)	Protocol A	(Stoic.)	2 h	88	[1]
3	2-(Benzylamino)	Protocol B	PPA (Microwave)	15 min	78	[3]
4	2-(Phenylethyl)	Protocol B	CholineCl/ Oxalic Acid	10 min	90	[4]
5	2-(Aryl)	Protocol A	PEG-	1.5 h	94	[5]

### Optimization Tips:

- **Electronic Effects:** Electron-withdrawing groups on the aminophenol (e.g., -NO<sub>2</sub>) retard the nucleophilic attack; increase temperature or catalyst loading.
- **Steric Bulk:** Bulky amino acids (e.g., Valine, Isoleucine) require longer reaction times in Protocol B.

- Oxidant Choice: For Protocol A, using air/O<sub>2</sub> is possible but slower.

or TBHP accelerates the re-oxidation of HI to

.

## References

- Iodine-catalyzed synthesis of benzoxazoles using catechols, ammonium acetate, and alkenes. Semantic Scholar. [\[Link\]](#)
- Facile and Efficient One-Pot Protocol for the Synthesis of Benzoxazole and Benzothiazole Derivatives Using Molecular Iodine as Catalyst. ResearchGate. [\[Link\]](#)
- Microwave-assisted Synthesis of Benzoxazoles Derivatives. Bentham Science. [\[Link\]](#)
- Rapid and Simple Microwave-Assisted Synthesis of Benzoxazoles Catalyzed by [CholineCl] [Oxalic Acid]. MDPI. [\[Link\]](#)
- Facile and efficient synthesis of benzoxazole derivatives using novel catalytic activity of PEG-SO<sub>3</sub>H. Arabian Journal of Chemistry. [\[Link\]](#)
- One-pot synthesis of 2-arylated and 2-alkylated benzoxazoles and benzimidazoles based on triphenylbismuth dichloride-promoted desulfurization of thioamides. Beilstein Journal of Organic Chemistry. [\[Link\]](#)

### Need Custom Synthesis?

BenchChem offers custom synthesis for rare earth carbides and specific isotopic labeling.

Email: [info@benchchem.com](mailto:info@benchchem.com) or [Request Quote Online](#).

## Sources

- [1. Rapid and Simple Microwave-Assisted Synthesis of Benzoxazoles Catalyzed by \[CholineCl\]\[Oxalic Acid\] | MDPI \[mdpi.com\]](#)
- To cite this document: BenchChem. [Application Note: One-Pot Synthesis Methods for Benzoxazole Alkylamines]. BenchChem, [2026]. [Online PDF]. Available at:

[\[https://www.benchchem.com/product/b4653395/docs#application-note-one-pot-synthesis-methods-for-benzoxazole-alkylamines\]](https://www.benchchem.com/product/b4653395/docs#application-note-one-pot-synthesis-methods-for-benzoxazole-alkylamines)

### Disclaimer & Data Validity:

The information provided in this document is for Research Use Only (RUO) and is strictly not intended for diagnostic or therapeutic procedures. While BenchChem strives to provide accurate protocols, we make no warranties, express or implied, regarding the fitness of this product for every specific experimental setup.

**Technical Support:** The protocols provided are for reference purposes. Unsure if this reagent suits your experiment?

**Need Industrial/Bulk Grade?** [Request Custom Synthesis Quote](#)

## BenchChem

Our mission is to be the trusted global source of essential and advanced chemicals, empowering scientists and researchers to drive progress in science and industry.

### Contact

Address: 3281 E Guasti Rd  
Ontario, CA 91761, United States  
Phone: (601) 213-4426  
Email: [info@benchchem.com](mailto:info@benchchem.com)

[Contact our Ph.D. Support Team for a compatibility check](#)