

Strategic Azidation Guide: Diphenyl Azidophosphate (DPPA) vs. Sodium Azide ()

Author: BenchChem Technical Support Team. **Date:** February 2026

Compound of Interest

Compound Name: Diphenyl azidophosphate

CAS No.: 26386-88-9

Cat. No.: B045318

[Get Quote](#)

Executive Summary

In drug development, the introduction of an azide moiety is a pivotal gateway to amines (via reduction), isocyanates (via rearrangement), or triazoles (via Click chemistry). However, the choice between Sodium Azide ()

) and **Diphenyl Azidophosphate** (DPPA) is rarely a simple swap; it is a strategic decision dictated by substrate stability, safety engineering, and process scalability.

- Use Sodium Azide () when: You have a primary alkyl halide/sulfonate, require high atom economy, are cost-constrained, and have robust engineering controls for managing hydrazoic acid () and heavy metal hazards.
- Use DPPA when: You need to convert alcohols or carboxylic acids directly (one-pot), require stereochemical inversion on secondary alcohols, or need to perform a Curtius rearrangement without isolating explosive acyl azide intermediates.

Part 1: The Safety & Handling Paradigm

The "Elephant in the Room" for azidation is explosivity.^{[1][2]} While both reagents introduce energetic nitrogen, their risk profiles differ fundamentally.

Sodium Azide (): The "Brute Force" Nucleophile

is a high-energy solid that demands respect. Its primary risks are not just thermal instability, but incompatibility.

- Acid Sensitivity: Contact with acid (even weak acids during workup) generates Hydrazoic Acid (), a volatile, highly toxic, and explosive gas.
- Metal Incompatibility: Reacts with copper, lead, and brass (common in plumbing/rotovaps) to form heavy metal azides, which are shock-sensitive primary explosives.
- Halogenated Solvents: Never reflux in dichloromethane ().^[3] This forms diazidomethane, a compound known to detonate without warning.

Diphenyl Azidophosphate (DPPA): The "Sophisticated" Liquid

DPPA is a high-boiling liquid (bp 157°C) that offers a safety buffer.

- Stability: It is generally non-explosive at room temperature and shock-insensitive. However, it decomposes exothermically above 200°C.
- Toxicity: It is a lachrymator and highly toxic (organophosphate), requiring good ventilation, but it eliminates the dust hazard associated with solid .
- Process Safety: In Curtius rearrangements, DPPA allows the formation and consumption of the acyl azide intermediate in situ, preventing the accumulation of large quantities of explosive material.

Part 2: Mechanistic Divergence & Substrate Scope

The choice of reagent dictates the reaction pathway.

relies on displacement, while DPPA utilizes phosphoryl transfer to activate oxygenated substrates.

Visualization: Reaction Pathways

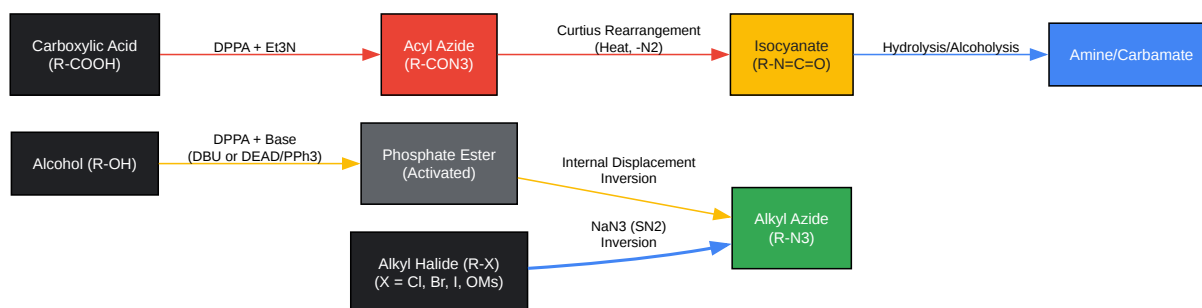

[Click to download full resolution via product page](#)

Caption: Comparative reaction pathways.

follows a direct

route, while DPPA activates oxygenated substrates (Alcohols/Acids) for subsequent substitution or rearrangement.

Comparative Performance Data

Feature	Sodium Azide ()	Diphenyl Azidophosphate (DPPA)
Primary Mechanism	Nucleophilic Substitution	Phosphoryl Transfer / Curtius
Substrate Requirement	Good Leaving Group (Halide, OTs, OMs)	Hydroxyl (-OH) or Carboxyl (-COOH)
Stereochemistry	Inversion (Walden)	Inversion (Mitsunobu/Thompson)
Atom Economy	High ()	Low (, generates phosphate waste)
Cost	Very Low	High
Purification	Simple (Extraction)	Moderate (Phosphate byproducts)
Key Application	Bulk preparation of primary azides	Curtius Rearrangement; Direct azidation of alcohols

Part 3: Experimental Protocols (Self-Validating)

Protocol A: Classical Azidation with

Best for: Primary alkyl halides or mesylates.

Safety Critical: Do not use halogenated solvents (

,

).^[3] Use a blast shield.^[1]^[3]

- Preparation: Dissolve substrate (1.0 equiv) in DMF or DMSO (0.5 M). These polar aprotic solvents accelerate the reaction.
- Addition: Add

(1.2–1.5 equiv) carefully.

◦ Note:

is not soluble in most organic solvents but dissolves in DMF/DMSO.

- Reaction: Stir at RT to 60°C. Monitor by TLC/LCMS.
- The Nitrite Quench (Validation Step):
 - Why: Excess azide in the waste stream is a ticking time bomb.
 - Procedure: After workup, treat the aqueous waste with Sodium Nitrite () and slowly acidify with dilute . This converts residual azide to benign and .
 - Reaction: .
- Workup: Dilute with water, extract into EtOAc or . Wash organic layer with water () to remove DMF.

Protocol B: One-Pot Curtius Rearrangement with DPPA

Best for: Converting Carboxylic Acids to Amines/Carbamates.

Safety Critical: Evolution of

gas. Ensure system is vented.

- Activation: Dissolve Carboxylic Acid (1.0 equiv) in Toluene (anhydrous). Add Triethylamine (

, 1.1 equiv).[1]

- Reagent Addition: Add DPPA (1.1 equiv) dropwise at RT.
 - Mechanism:[4][5][6][7][8][9] Forms the acyl azide intermediate in situ.
- Rearrangement: Heat the mixture to 80–110°C.
 - Observation: Vigorous evolution of

gas indicates the rearrangement to Isocyanate is occurring.
- Trapping (The "One-Pot" Magic):
 - For Carbamates: Add excess alcohol (e.g., t-BuOH, BnOH) and reflux.
 - For Ureas: Add an amine.[1][9][10][11][12]
 - For Amines: Add water (hydrolysis).
- Purification: Cool, dilute with EtOAc, wash with 1M HCl (to remove base) and saturated

(to remove phosphate byproducts).

Part 4: Decision Matrix for Process Scale-Up

When moving from mg to kg scale, the decision logic shifts from "convenience" to "safety and cost."

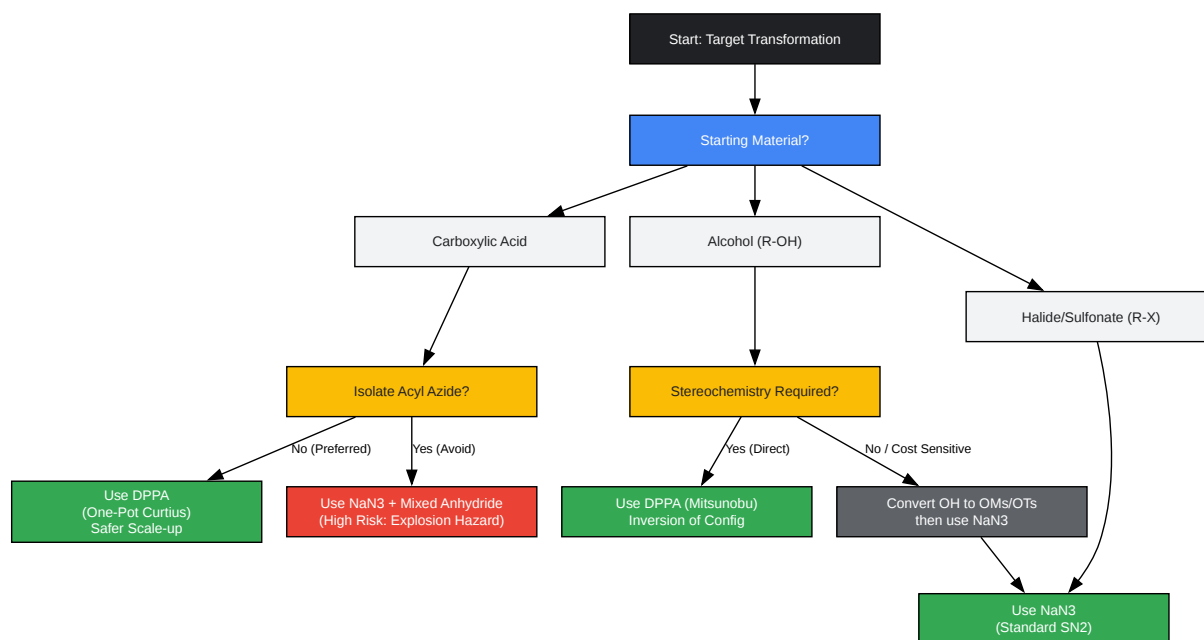

[Click to download full resolution via product page](#)

Caption: Strategic decision tree for selecting azidation reagents based on substrate functional groups and process safety constraints.

References

- Shioiri, T., Ninomiya, K., & Yamada, S. (1972). Diphenylphosphoryl azide.[1][9][11][12][13] A new convenient reagent for a modified Curtius reaction and for the peptide synthesis.[13] Journal of the American Chemical Society, 94(17), 6203–6205. [Link](#)

- Thompson, A. S., et al. (1993). Direct conversion of alcohols to azides using diphenyl phosphorazidate and 1,8-diazabicyclo[5.4.0]undec-7-ene (DBU).[14][6][15][16] Journal of Organic Chemistry, 58(22), 5886–5888. [Link](#)
- Lebel, H., & Leogane, O. (2009). Boc-Protected Amines via a Mild and Efficient One-Pot Curtius Rearrangement. Organic Syntheses, 86, 113-120.[2] [Link](#)
- University of Wisconsin-Madison EHS. Safe Handling of Sodium Azide. Environment, Health & Safety Guidelines. [Link](#)
- Common Organic Chemistry. Diphenylphosphoryl Azide (DPPA) Reagent Profile. [Link](#)

Need Custom Synthesis?

BenchChem offers custom synthesis for rare earth carbides and specific isotopic labeling.

Email: info@benchchem.com or [Request Quote Online](#).

Sources

- 1. benchchem.com [benchchem.com]
- 2. orgsyn.org [orgsyn.org]
- 3. chemistry.unm.edu [chemistry.unm.edu]
- 4. researchgate.net [researchgate.net]
- 5. Curtius Rearrangement [organic-chemistry.org]
- 6. Page loading... [wap.guidechem.com]
- 7. uthsc.edu [uthsc.edu]
- 8. Safe and highly efficient adaptation of potentially explosive azide chemistry involved in the synthesis of Tamiflu using continuous-flow technology - PMC [[pmc.ncbi.nlm.nih.gov](https://pubmed.ncbi.nlm.nih.gov/31111111/)]
- 9. The Curtius Rearrangement: Applications in Modern Drug Discovery and Medicinal Chemistry - PMC [[pmc.ncbi.nlm.nih.gov](https://pubmed.ncbi.nlm.nih.gov/31111111/)]
- 10. Thieme E-Journals - Synlett / Abstract [[thieme-connect.com](https://www.thieme-connect.com)]
- 11. tcichemicals.com [tcichemicals.com]
- 12. Diphenylphosphoryl azide - Wikipedia [[en.wikipedia.org](https://en.wikipedia.org/wiki/Diphenylphosphoryl_azide)]

- [13. Diphenylphosphoryl azide. A new convenient reagent for a modified Curtus reaction and for the peptide synthesis - PubMed \[pubmed.ncbi.nlm.nih.gov\]](#)
- [14. pubs.acs.org \[pubs.acs.org\]](#)
- [15. Diphenylphosphoryl Azide \(DPPA\) \[commonorganicchemistry.com\]](#)
- [16. polymer.chem.cmu.edu \[polymer.chem.cmu.edu\]](#)
- To cite this document: BenchChem. [Strategic Azidation Guide: Diphenyl Azidophosphate (DPPA) vs. Sodium Azide ()]. BenchChem, [2026]. [Online PDF]. Available at: [<https://www.benchchem.com/product/b045318#diphenyl-azidophosphate-vs-sodium-azide-for-azidation-reactions>]

Disclaimer & Data Validity:

The information provided in this document is for Research Use Only (RUO) and is strictly not intended for diagnostic or therapeutic procedures. While BenchChem strives to provide accurate protocols, we make no warranties, express or implied, regarding the fitness of this product for every specific experimental setup.

Technical Support: The protocols provided are for reference purposes. Unsure if this reagent suits your experiment? [[Contact our Ph.D. Support Team for a compatibility check](#)]

Need Industrial/Bulk Grade? [Request Custom Synthesis Quote](#)

BenchChem

Our mission is to be the trusted global source of essential and advanced chemicals, empowering scientists and researchers to drive progress in science and industry.

Contact

Address: 3281 E Guasti Rd

Ontario, CA 91761, United States

Phone: (601) 213-4426

Email: info@benchchem.com