

# Regulating the Cellular Pool of Cytidine Diphosphate: A Technical Guide

**Author:** BenchChem Technical Support Team. **Date:** April 2026

## Compound of Interest

Compound Name: Cytidine Diphosphate

CAS No.: 63-38-7

Cat. No.: B045696

[Get Quote](#)

Authored for Researchers, Scientists, and Drug Development Professionals

## Abstract

Intracellular levels of **Cytidine Diphosphate** (CDP) are meticulously controlled to ensure cellular homeostasis and support critical biological processes. As a key precursor for the synthesis of DNA, RNA, and essential phospholipids, the regulation of the CDP pool is paramount for cell growth, proliferation, and membrane integrity. This technical guide provides an in-depth exploration of the core mechanisms governing intracellular CDP concentrations, focusing on the enzymatic regulation of its synthesis and its utilization in major metabolic pathways. We present a comprehensive overview of the allosteric and feedback control of CTP synthase, the rate-limiting enzyme in de novo CTP production. Furthermore, this guide details the kinetics of key enzymes in the CDP-choline and CDP-diacylglycerol pathways, which consume CDP to produce vital membrane phospholipids. Quantitative data on enzyme kinetics and inhibitor efficiencies are summarized in structured tables for comparative analysis. Detailed experimental protocols for the determination of intracellular CDP levels and the enzymatic activity of CTP synthase are provided, alongside visual representations of key signaling and metabolic pathways to facilitate a deeper understanding of this intricate regulatory network.

This guide is intended to serve as a valuable resource for researchers investigating nucleotide metabolism and for professionals engaged in the development of therapeutic agents targeting these pathways.

## Introduction

**Cytidine Diphosphate** (CDP) occupies a central node in cellular metabolism. Its primary role is as a building block for the synthesis of deoxycytidine triphosphate (dCTP) for DNA replication and cytidine triphosphate (CTP) for RNA synthesis. CTP, in turn, is the direct precursor to CDP. Beyond its role in nucleic acid synthesis, CDP is a critical component in the biosynthesis of major phospholipids, including phosphatidylcholine (PC), phosphatidylethanolamine (PE), and phosphatidylinositol (PI). The availability of intracellular CDP is therefore intrinsically linked to cell division, membrane biogenesis, and signal transduction.

The regulation of intracellular CDP levels is primarily achieved through the stringent control of CTP synthase (CTPS), the enzyme that catalyzes the final step in the de novo synthesis of CTP from UTP.<sup>[1][2]</sup> This regulation occurs at multiple levels, including allosteric activation, feedback inhibition, and changes in the enzyme's oligomeric state.<sup>[2][3]</sup> Once synthesized, CTP is readily converted to CDP, which is then channeled into various metabolic pathways. This guide will delve into the molecular mechanisms that govern the flux of cytidine nucleotides, providing a detailed technical overview for researchers in the field.

## The Central Role of CTP Synthase in CDP Synthesis

The de novo synthesis of CTP is the primary source of intracellular cytidine nucleotides. This process culminates in the ATP-dependent amination of uridine triphosphate (UTP) to CTP, a reaction catalyzed by CTP synthase (CTPS).<sup>[1]</sup> Given its pivotal role, CTPS is subject to complex regulatory mechanisms to maintain appropriate intracellular CTP and, consequently, CDP pools.

## Allosteric Regulation and Feedback Inhibition

CTP synthase activity is finely tuned by the intracellular concentrations of various nucleotides. Guanosine triphosphate (GTP) acts as a positive allosteric activator, enhancing the enzyme's catalytic efficiency.<sup>[2][4]</sup> This activation is crucial for coordinating the synthesis of purine and pyrimidine nucleotides. Conversely, the end-product of the reaction, CTP, acts as a feedback

inhibitor, competing with the substrate UTP.[2][5] This feedback loop is a critical mechanism for preventing the overaccumulation of cytidine nucleotides.

## Oligomerization and Filament Formation

CTP synthase exists in a dynamic equilibrium between inactive dimeric and active tetrameric forms. The binding of the substrates ATP and UTP promotes the formation of the active tetramer.[2][5] Recent studies have revealed another layer of regulation involving the assembly of CTPS into large filamentous structures, also known as cytoophidia.[2] Filament formation is thought to be a mechanism for sequestering the enzyme in an inactive state, thereby downregulating CTP synthesis.

## Quantitative Analysis of Enzyme Kinetics

A thorough understanding of the regulation of CDP levels necessitates a quantitative analysis of the enzymes involved. The following tables summarize key kinetic parameters for CTP synthase and other relevant enzymes.

Enzyme	Organism/Isoform	Substrate	Km ( $\mu\text{M}$ )	Vmax ( $\mu\text{mol}/\text{min}/\text{mg}$ )	Activator/Inhibitor	KA/Ki/IC50 ( $\mu\text{M}$ )	Reference(s)
CTP Synthase	E. coli	UTP	150	-	CTP (inhibitor)	Ki = 110	[5]
CTP Synthase	E. coli	-	-	-	NADH (inhibitor)	IC50 = 470	[6]
CTP Synthase	E. coli	-	-	-	CTP (inhibitor)	IC50 $\approx$ 370	[6]
CTP Synthase	T. brucei	-	-	-	GTP (activator)	KA = 70	[7]
CTP Synthase	T. brucei	-	-	-	GTP (inhibitor)	Ki = 272	[7]
CTP Synthase 1 (human)	-	-	-	-	CTP Synthase-IN-1	IC50 = 0.032	[8]
CTP Synthase 2 (human)	-	-	-	-	CTP Synthase-IN-1	IC50 = 0.018	[8]
CTP Synthase (activated PBMCs)	Human	UTP	230 $\pm$ 280	379 $\pm$ 90 (pmol/min)	-	-	[9]
CTP Synthase (resting cells)	Human	UTP	280 $\pm$ 310	83 $\pm$ 20 (pmol/min)	-	-	[9]

Enzyme	Organism / Isoform	Substrate	Km (mM)	Vmax (μmol/min /mg)	Notes	Reference(s)
CTP:phosphocholine cytidyltransferase	Rat Lung (microsomal)	CTP	0.33 (with oleate)	-	Oleate decreases the Km for CTP.	[10]
CTP:phosphocholine cytidyltransferase	Rat Lung (microsomal)	CTP	0.99 (w/o oleate)	-		[10]
CDP-diacylglycerol Synthase 1 (CDS1)	Human	SAPA	-	3.3 ± 0.3	SAPA: 1-stearoyl-2-arachidonyl-sn-phosphatidic acid	[11][12]
CDP-diacylglycerol Synthase 1 (CDS1)	Human	SLPA	-	3.6 ± 0.1	SLPA: 1-stearoyl-2-linoleoyl-sn-phosphatidic acid	[11][12]
CDP-diacylglycerol Synthase 2 (CDS2)	Human	SAPA	-	9.3 ± 0.4		[11][12]
CDP-diacylglycerol Synthase 2 (CDS2)	Human	SLPA	-	3.5 ± 0.1		[11][12]

Cholinephosphotransferase	Mouse Liver	CDP-choline	Varies	Varies	Km for CDP-choline is dependent on the diacylglycerol species. <a href="#">[13]</a>
---------------------------	----------------	-------------	--------	--------	---

## Downstream Pathways Utilizing CDP

Once synthesized, CDP is a substrate for several essential biosynthetic pathways, primarily the CDP-choline and CDP-diacylglycerol pathways for phospholipid synthesis.

### The CDP-Choline Pathway

The CDP-choline pathway is the primary route for the synthesis of phosphatidylcholine (PC), a major component of eukaryotic membranes.[\[14\]](#)[\[15\]](#) The pathway involves the conversion of phosphocholine to CDP-choline by the enzyme CTP:phosphocholine cytidyltransferase (CCT).[\[15\]](#) This is the rate-limiting step in the pathway.[\[15\]](#) CDP-choline then reacts with diacylglycerol (DAG) to form PC, a reaction catalyzed by cholinephosphotransferase.[\[14\]](#) The activity of CCT is regulated by its association with membranes; it is inactive in the cytosol and becomes activated upon binding to membranes that are deficient in PC.[\[16\]](#)

### The CDP-Diacylglycerol Pathway

The CDP-diacylglycerol pathway is responsible for the synthesis of phosphatidylinositol (PI), phosphatidylglycerol (PG), and cardiolipin (CL).[\[17\]](#) The key enzyme in this pathway is CDP-diacylglycerol synthase (CDS), which catalyzes the formation of CDP-diacylglycerol from CTP and phosphatidic acid (PA).[\[17\]](#) CDP-diacylglycerol is a critical branch point intermediate in phospholipid metabolism.[\[17\]](#)

## Experimental Protocols

### Measurement of Intracellular CDP Levels by HPLC

Objective: To quantify the intracellular concentration of **Cytidine Diphosphate** (CDP) in cultured cells.

Principle: This method utilizes reversed-phase ion-pair high-performance liquid chromatography (HPLC) for the separation and quantification of intracellular nucleotides.[18] Cell extracts are prepared, and the nucleotides are separated on a C18 column using a mobile phase containing an ion-pairing agent, which allows for the retention and separation of the negatively charged nucleotides. Detection is typically performed using UV absorbance at 254 nm.

#### Materials:

- Cultured cells
- Trichloroacetic acid (TCA)
- Tetrabutylammonium hydroxide
- Potassium phosphate monobasic (KH<sub>2</sub>PO<sub>4</sub>)
- Methanol (HPLC grade)
- CDP standard
- HPLC system with a UV detector and a C18 column

#### Procedure:

- Cell Lysis and Extraction:
  - Harvest cultured cells by trypsinization or scraping.
  - Wash the cell pellet with ice-cold PBS.
  - Resuspend the cell pellet in a known volume of ice-cold 6% TCA.
  - Incubate on ice for 15 minutes to precipitate proteins.
  - Centrifuge at 14,000 x g for 10 minutes at 4°C.
  - Carefully collect the supernatant containing the acid-soluble nucleotides.

- Neutralization:
  - Neutralize the TCA extract by adding a calculated amount of 5 M K<sub>2</sub>CO<sub>3</sub> until the pH is between 6.5 and 7.5.
  - Centrifuge to remove the potassium perchlorate precipitate.
- HPLC Analysis:
  - Equilibrate the C18 column with the mobile phase. A typical mobile phase consists of a buffer containing tetrabutylammonium hydroxide as the ion-pairing agent and potassium phosphate, with a methanol gradient for elution.[18]
  - Inject a known volume of the neutralized cell extract onto the HPLC column.
  - Run a gradient elution program to separate the nucleotides.
  - Monitor the absorbance at 254 nm.
- Quantification:
  - Identify the CDP peak by comparing its retention time to that of a CDP standard.
  - Quantify the amount of CDP by integrating the peak area and comparing it to a standard curve generated with known concentrations of CDP.
  - Normalize the CDP amount to the cell number or total protein concentration.

## CTP Synthase Activity Assay

Objective: To measure the enzymatic activity of CTP synthase in cell lysates.

Principle: This assay measures the production of CTP from UTP and glutamine. The reaction is coupled to a detection system, often involving the separation and quantification of the CTP product by HPLC or LC-MS/MS.[9][19]

Materials:

- Cell lysate containing CTP synthase

- Assay buffer (e.g., HEPES or Tris-HCl, pH 8.0)
- ATP
- UTP
- Glutamine
- GTP (as an activator)
- MgCl<sub>2</sub>
- HPLC or LC-MS/MS system

Procedure:

- Preparation of Cell Lysate:
  - Harvest cells and wash with PBS.
  - Lyse the cells using a suitable lysis buffer (e.g., containing a non-ionic detergent and protease inhibitors) on ice.
  - Centrifuge the lysate to remove cell debris and collect the supernatant.
  - Determine the protein concentration of the lysate.
- Enzyme Reaction:
  - Prepare a reaction mixture containing the assay buffer, MgCl<sub>2</sub>, ATP, UTP, glutamine, and GTP.
  - Pre-warm the reaction mixture to the desired temperature (e.g., 37°C).
  - Initiate the reaction by adding a known amount of the cell lysate.
  - Incubate the reaction for a defined period (e.g., 20-30 minutes), ensuring the reaction is in the linear range.

- Stop the reaction by adding an acid (e.g., TCA or perchloric acid) or by heat inactivation.
- Product Quantification:
  - Process the reaction mixture to remove precipitated protein (similar to the nucleotide extraction protocol).
  - Analyze the supernatant for the amount of CTP produced using HPLC or LC-MS/MS as described above.
- Calculation of Activity:
  - Calculate the amount of CTP produced per unit time per amount of protein (e.g., pmol/min/mg protein).

## Signaling Pathways and Logical Relationships

The regulation of intracellular CDP levels is a complex interplay of metabolic pathways and signaling networks. The following diagrams, generated using Graphviz, illustrate these relationships.

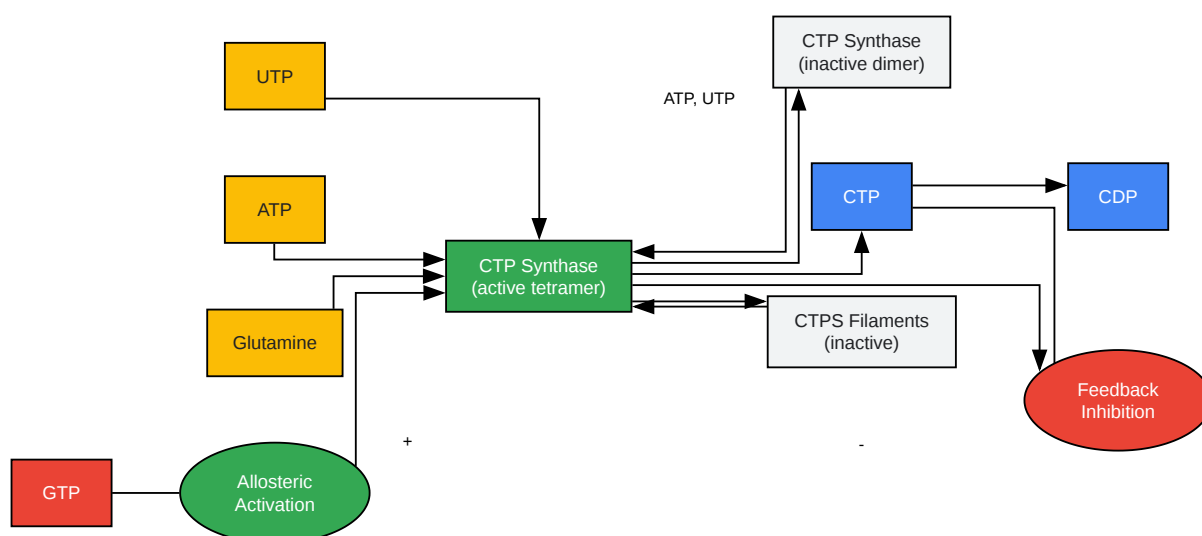

[Click to download full resolution via product page](#)

Caption: Regulation of CTP Synthase activity and CDP synthesis.

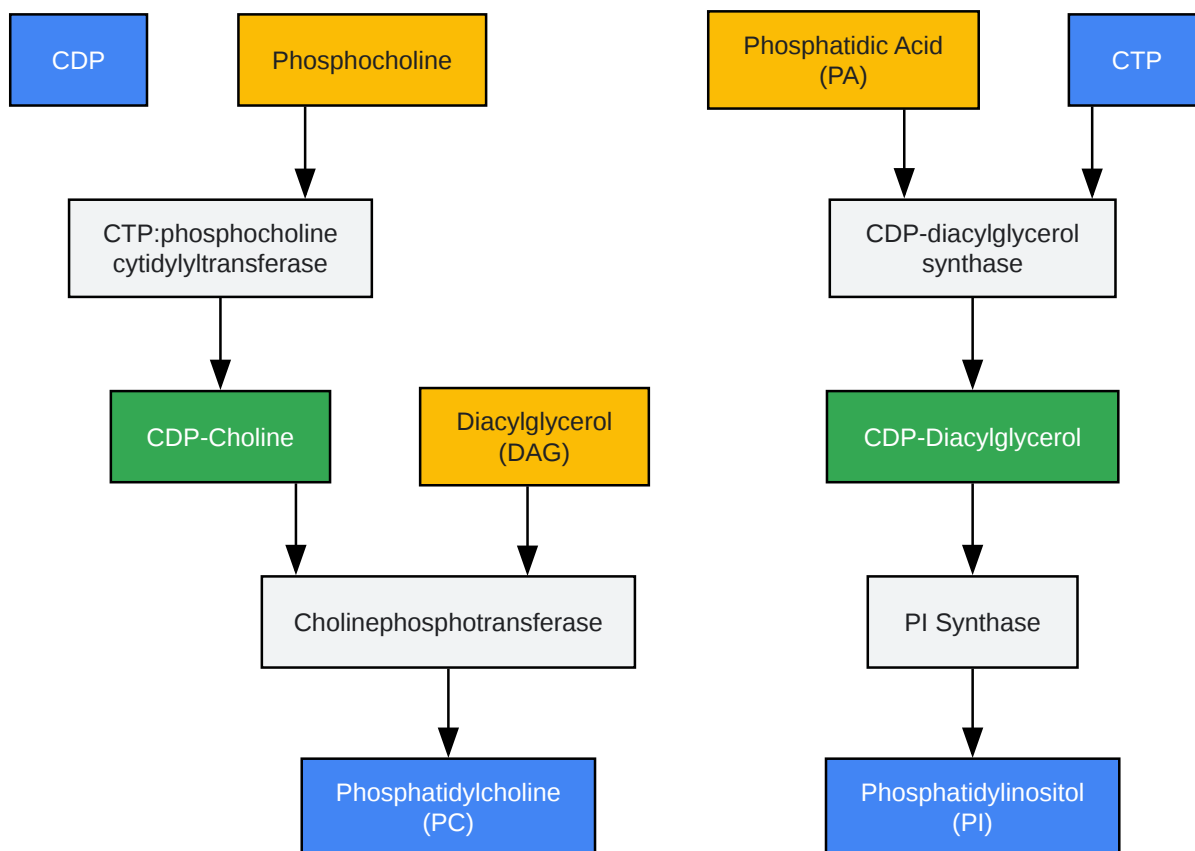

[Click to download full resolution via product page](#)

Caption: Major metabolic pathways utilizing CDP for phospholipid synthesis.

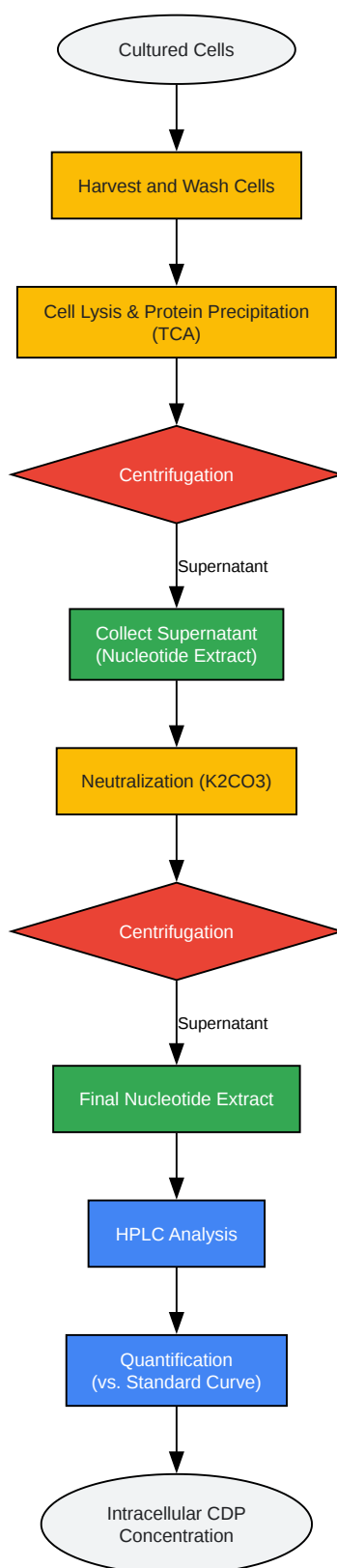

[Click to download full resolution via product page](#)

Caption: Experimental workflow for intracellular CDP quantification.

## Conclusion

The regulation of intracellular CDP levels is a highly orchestrated process, central to cellular life. The activity of CTP synthase, the gatekeeper of de novo cytidine nucleotide synthesis, is exquisitely controlled by a combination of allosteric regulation, feedback inhibition, and dynamic changes in its quaternary structure. The resulting CDP pool is then efficiently channeled into essential biosynthetic pathways, most notably for the production of membrane phospholipids. A comprehensive understanding of these regulatory networks is crucial for basic research into cell metabolism and proliferation. Moreover, the enzymes involved in these pathways, particularly CTP synthase, represent promising targets for the development of novel therapeutics for a range of diseases, including cancer and infectious diseases. This guide provides a foundational resource for researchers and drug development professionals to navigate the complexities of CDP metabolism and to design experiments aimed at further elucidating its regulation and therapeutic potential.

### *Need Custom Synthesis?*

*BenchChem offers custom synthesis for rare earth carbides and specific isotopic labeling.*

*Email: [info@benchchem.com](mailto:info@benchchem.com) or [Request Quote Online](#).*

## References

- [1. pubs.acs.org \[pubs.acs.org\]](https://pubs.acs.org)
- [2. Common regulatory control of CTP synthase enzyme activity and filament formation - PMC \[pmc.ncbi.nlm.nih.gov\]](https://pubmed.ncbi.nlm.nih.gov/)
- [3. molbiolcell.org \[molbiolcell.org\]](https://pubmed.ncbi.nlm.nih.gov/)
- [4. GTP-Dependent Regulation of CTP Synthase: Evolving Insights into Allosteric Activation and NH<sub>3</sub> Translocation - PMC \[pmc.ncbi.nlm.nih.gov\]](https://pubmed.ncbi.nlm.nih.gov/)
- [5. Mechanisms of Product Feedback Regulation and Drug Resistance in Cytidine Triphosphate Synthetases from the Structure of a CTP-Inhibited Complex - PMC \[pmc.ncbi.nlm.nih.gov\]](https://pubmed.ncbi.nlm.nih.gov/)
- [6. Inhibition of Escherichia coli CTP Synthetase by NADH and Other Nicotinamides and Their Mutual Interactions with CTP and GTP - PMC \[pmc.ncbi.nlm.nih.gov\]](https://pubmed.ncbi.nlm.nih.gov/)
- [7. mdpi.com \[mdpi.com\]](https://pubmed.ncbi.nlm.nih.gov/)

- [8. medchemexpress.com \[medchemexpress.com\]](https://www.medchemexpress.com)
- [9. CTP synthetase activity assay by liquid chromatography tandem mass spectrometry in the multiple reaction monitoring mode - PubMed \[pubmed.ncbi.nlm.nih.gov\]](https://pubmed.ncbi.nlm.nih.gov/)
- [10. Microsomal CTP:choline phosphate cytidyltransferase: kinetic mechanism of fatty acid stimulation - PubMed \[pubmed.ncbi.nlm.nih.gov\]](https://pubmed.ncbi.nlm.nih.gov/)
- [11. pubs.acs.org \[pubs.acs.org\]](https://pubs.acs.org)
- [12. researchgate.net \[researchgate.net\]](https://www.researchgate.net)
- [13. Kinetic selectivity of cholinephosphotransferase in mouse liver: the Km for CDP-choline depends on diacylglycerol structure - PubMed \[pubmed.ncbi.nlm.nih.gov\]](https://pubmed.ncbi.nlm.nih.gov/)
- [14. CDP-choline pathway - Wikipedia \[en.wikipedia.org\]](https://en.wikipedia.org)
- [15. Phosphatidylcholine and the CDP-Choline Cycle - PMC \[pmc.ncbi.nlm.nih.gov\]](https://pubmed.ncbi.nlm.nih.gov/)
- [16. Regulation of CTP:phosphocholine cytidyltransferase by amphitropism and relocalization - PubMed \[pubmed.ncbi.nlm.nih.gov\]](https://pubmed.ncbi.nlm.nih.gov/)
- [17. CDP-Diacylglycerol Synthases \(CDS\): Gateway to Phosphatidylinositol and Cardiolipin Synthesis - PMC \[pmc.ncbi.nlm.nih.gov\]](https://pubmed.ncbi.nlm.nih.gov/)
- [18. Analysis of intracellular nucleoside triphosphate levels in normal and tumor cell lines by high-performance liquid chromatography - PubMed \[pubmed.ncbi.nlm.nih.gov\]](https://pubmed.ncbi.nlm.nih.gov/)
- [19. Characterization of filament-forming CTP synthases from Arabidopsis thaliana - PMC \[pmc.ncbi.nlm.nih.gov\]](https://pubmed.ncbi.nlm.nih.gov/)
- To cite this document: BenchChem. [Regulating the Cellular Pool of Cytidine Diphosphate: A Technical Guide]. BenchChem, [2026]. [Online PDF]. Available at: [\[https://www.benchchem.com/product/b045696/docs#regulating-the-cellular-pool-of-cytidine-diphosphate-a-technical-guide\]](https://www.benchchem.com/product/b045696/docs#regulating-the-cellular-pool-of-cytidine-diphosphate-a-technical-guide)

---

### Disclaimer & Data Validity:

The information provided in this document is for Research Use Only (RUO) and is strictly not intended for diagnostic or therapeutic procedures. While BenchChem strives to provide accurate protocols, we make no warranties, express or implied, regarding the fitness of this product for every specific experimental setup.

**Technical Support:** The protocols provided are for reference purposes. Unsure if this reagent suits your experiment?

**Need Industrial/Bulk Grade?** [Request Custom Synthesis Quote](#)

## BenchChem

Our mission is to be the trusted global source of essential and advanced chemicals, empowering scientists and researchers to drive progress in science and industry.

### Contact

Address: 3281 E Guasti Rd  
Ontario, CA 91761, United States  
Phone: (601) 213-4426  
Email: [info@benchchem.com](mailto:info@benchchem.com)

[Contact our Ph.D. Support Team for a compatibility check](#)