

Technical Guide: 1,2-Bis(methylsulfonylsulfanyl)ethane (MTS-2-MTS)

Author: BenchChem Technical Support Team. **Date:** May 2026

Compound of Interest

Compound Name:	1,2-Bis(methylsulfonylsulfanyl)ethane
CAS No.:	55-95-8
Cat. No.:	B043724

[Get Quote](#)

Mechanism, Protocol, and Structural Probing Applications

Executive Summary

1,2-Bis(methylsulfonylsulfanyl)ethane is a homobifunctional, thiol-specific crosslinking reagent belonging to the methanethiosulfonate (MTS) class.[1] Unlike non-specific crosslinkers (e.g., glutaraldehyde) or amine-reactive esters (e.g., NHS-esters), this reagent targets cysteine sulfhydryls with high specificity and rapid kinetics.[2]

Its primary utility lies in the Substituted Cysteine Accessibility Method (SCAM) and molecular ruler experiments. By inserting a flexible, disulfide-containing bridge of precise length (~5.2 Å) between two cysteine residues, researchers can map distances within protein complexes, validate homology models, and freeze dynamic conformational states of ion channels and transporters.

Part 1: Chemical Basis & Mechanism of Action

The Reactive Moiety

The reagent consists of two methanethiosulfonate reactive groups separated by a 2-carbon ethyl spacer.

- Chemical Formula:
- Reactive Center: The sulfur atom of the sulfenyl group (attached to the spacer).
- Leaving Group: Methanesulfinate ().

Reaction Mechanism

The reaction is a specific nucleophilic substitution (S_N2)-like) where the thiolate anion (RS^-) of a protein cysteine attacks the sulfenyl sulfur of the reagent.

- Activation: The protein cysteine must be in its deprotonated thiolate form (RS^-). This is pH-dependent (typically $pH > 7.0$).
- First Attack (Mono-adduct formation): The thiolate attacks one end of the MTS-2-MTS, displacing methanesulfinate. The protein is now "tagged" with a reactive arm.[3]
- Second Attack (Crosslinking): If a second cysteine is within the spatial reach of the spacer arm (approx. 6 Å), it attacks the remaining MTS group, displacing the second methanesulfinate and forming a stable bis-disulfide bridge.

Resulting Bridge Structure:

Visualization: Reaction Coordinate

The following diagram illustrates the stepwise formation of the crosslink.

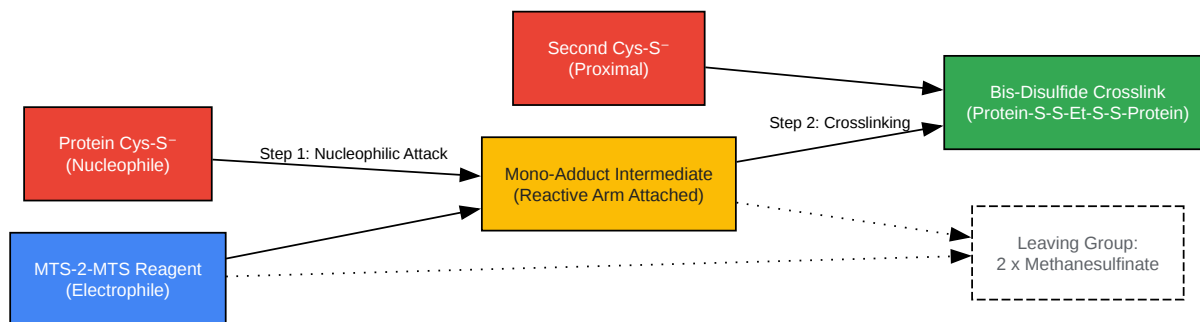

[Click to download full resolution via product page](#)

Figure 1: Stepwise mechanism of cysteine crosslinking by MTS-2-MTS. The reaction generates a covalent bis-disulfide bridge and releases methanesulfinate.

Part 2: Structural Biology Applications[1][3][4][5]

The "Molecular Ruler" Concept

MTS-2-MTS is often used in a series with other analogs (MTS-1-MTS, MTS-3-MTS, etc.) to measure the physical distance between two residues.

- Success: If MTS-2-MTS (5.2 Å) crosslinks but MTS-1-MTS (3.6 Å) does not, the cysteines are likely 4–6 Å apart.
- Failure: If no crosslink forms, the cysteines may be too distant, sterically occluded, or the protein may be in a conformation that separates them.

Functional Locking (State-Dependent Trapping)

In ion channels (e.g., GABA-A, CFTR), researchers introduce cysteines at predicted interface sites.

- Open State Trapping: If the crosslinker locks the channel in an open conformation, it proves those residues move closer during gating.
- Inhibition: If the crosslinker blocks the pore physically, it maps the pore diameter.

Part 3: Experimental Protocol

Reagent Handling (Critical)

MTS reagents are highly susceptible to hydrolysis.^[2]

- Storage: Store lyophilized powder at -20°C with desiccant.
- Solubilization: Dissolve in anhydrous DMSO or Acetonitrile immediately before use. Do not store aqueous solutions.
- Working Concentration: Typically 0.1 mM to 10 mM, depending on target abundance and reactivity.

Standard Crosslinking Workflow

This protocol assumes a purified protein or membrane fraction.

Step	Action	Technical Rationale
1. Reduction	Treat sample with 1-5 mM DTT or TCEP for 15-30 min.	Ensures target cysteines are reduced (-SH) and available for reaction.
2. Desalting	Remove reducing agent via size-exclusion spin column or dialysis.	Crucial: Residual DTT will instantly quench the MTS reagent.
3. Equilibration	Buffer exchange to pH 7.5 – 8.0 (HEPES or Phosphate).	Higher pH favors the thiolate anion (), accelerating the reaction.
4. Labeling	Add MTS-2-MTS (from DMSO stock) to 10-fold molar excess. Incubate 5–30 mins on ice or RT.	Rapid kinetics usually require short incubation. Long incubation risks non-specific aggregation.
5. Quenching	Add 20 mM L-Cysteine or N-ethylmaleimide (NEM).	Scavenges unreacted MTS reagent to prevent post-lysis artifacts.
6. Analysis	SDS-PAGE (Non-reducing) followed by Western Blot.	Crosslinked proteins will migrate slower (dimer) or show a band shift compared to uncrosslinked controls.

Verification of Specificity

To prove the effect is due to the specific crosslink:

- DTT Reversal: Treat the crosslinked sample with 100 mM DTT. The crosslink (disulfide-based) should break, restoring the monomeric band on SDS-PAGE.
- Cys-less Control: Perform the assay on a "Cys-less" background mutant to ensure the reagent isn't reacting with native cysteines.

Workflow Visualization

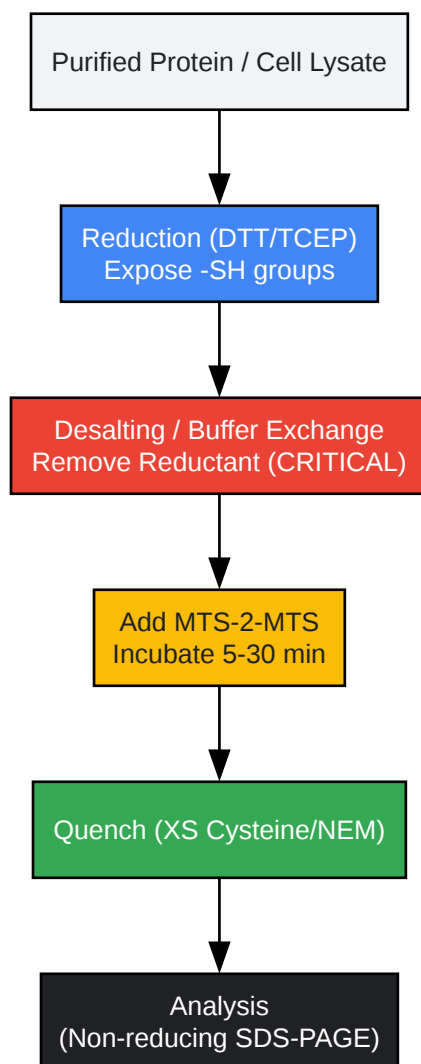

[Click to download full resolution via product page](#)

Figure 2: Operational workflow for protein crosslinking. Step 3 (Desalting) is the most common point of failure.

Part 4: Data Interpretation & Troubleshooting

Interpreting Gel Shifts

- Intra-molecular Crosslink: The protein band may become "tighter" or shift slightly due to compaction (preventing full denaturation).
- Inter-molecular Crosslink: A new band appears at (dimer) or higher oligomers.

Common Issues

- No Crosslinking:
 - pH too low (Cysteines protonated).
 - Residual reducing agent present (MTS hydrolyzed).
 - Cysteines are >10 Å apart.
- Smearing/Aggregation:
 - Reagent concentration too high.
 - Incubation too long.
 - Non-specific reaction with surface amines (rare at pH < 8, but possible with high excess).

References

- Akabas, M. H., Stauffer, D. A., Xu, M., & Karlin, A. (1992). Acetylcholine receptor channel structure probed in the native membrane with substituted cysteine accessibility method. *Science*.^[4]
- Loo, T. W., & Clarke, D. M. (2001). Mapping the binding site of the inhibitor rhodamine B in the multidrug resistance P-glycoprotein. *Journal of Biological Chemistry*.
- Toronto Research Chemicals. **1,2-Bis(methylsulfonylsulfanyl)ethane (MTS-2-MTS)** Product Information.
- Santa Cruz Biotechnology. 1,2-Ethanediy l Bismethanethiosulfonate (MTS-2-MTS) Data Sheet.
- Biotium. MTS Reagents for Cysteine Accessibility Studies.

Need Custom Synthesis?

BenchChem offers custom synthesis for rare earth carbides and specific isotopic labeling.

Email: info@benchchem.com or [Request Quote Online](#).

Sources

- [1. researchgate.net \[researchgate.net\]](https://www.researchgate.net)
- [2. ttuhsc.edu \[ttuhsc.edu\]](https://www.ttuhs.edu)
- [3. Rapid Mapping of Protein Interactions Using Tag-Transfer Photocrosslinkers - PMC \[pmc.ncbi.nlm.nih.gov\]](https://pubmed.ncbi.nlm.nih.gov/)
- [4. documents.thermofisher.com \[documents.thermofisher.com\]](https://www.documents.thermofisher.com)
- To cite this document: BenchChem. [Technical Guide: 1,2-Bis(methylsulfonylsulfanyl)ethane (MTS-2-MTS)]. BenchChem, [2026]. [Online PDF]. Available at: [\[https://www.benchchem.com/product/b043724/docs#technical-guide-1-2-bis-methylsulfonylsulfanyl-ethane-mts-2-mts\]](https://www.benchchem.com/product/b043724/docs#technical-guide-1-2-bis-methylsulfonylsulfanyl-ethane-mts-2-mts)

Disclaimer & Data Validity:

The information provided in this document is for Research Use Only (RUO) and is strictly not intended for diagnostic or therapeutic procedures. While BenchChem strives to provide accurate protocols, we make no warranties, express or implied, regarding the fitness of this product for every specific experimental setup.

Technical Support: The protocols provided are for reference purposes. Unsure if this reagent suits your experiment?

Need Industrial/Bulk Grade? [Request Custom Synthesis Quote](#)

BenchChem

Our mission is to be the trusted global source of essential and advanced chemicals, empowering scientists and researchers to drive progress in science and industry.

Contact

Address: 3281 E Guasti Rd

Ontario, CA 91761, United States

Phone: (601) 213-4426

Email: info@benchchem.com

Contact our Ph.D. Support Team for a compatibility check