

# Discovery and history of N-substituted piperazinones

**Author:** BenchChem Technical Support Team. **Date:** January 2026

## Compound of Interest

Compound Name: 1-Ethylpiperazin-2-one

Cat. No.: B043009

[Get Quote](#)

An In-depth Technical Guide to the Discovery and History of N-Substituted Piperazinones For Researchers, Scientists, and Drug Development Professionals

## Abstract

The N-substituted piperazinone core is a privileged scaffold in medicinal chemistry, forming the structural basis of a wide array of therapeutic agents. This guide provides a comprehensive overview of the discovery and historical evolution of synthetic methodologies for N-substituted piperazinones. We traverse the timeline from early, classical syntheses to the advent of modern catalytic and asymmetric strategies. This document is intended to serve as a valuable resource for researchers and professionals in drug discovery and development, offering insights into the chemical causality behind experimental choices and providing detailed, field-proven protocols for the synthesis of this important heterocyclic motif.

## Introduction: The Emergence of the Piperazinone Scaffold

The piperazine ring system, a six-membered heterocycle containing two nitrogen atoms at the 1 and 4 positions, has long been recognized for its favorable physicochemical properties in drug design.[1] The introduction of a carbonyl group at the 2-position to form a piperazin-2-one imparts a degree of conformational rigidity and provides an additional site for molecular recognition, making it a highly attractive scaffold for medicinal chemists.[2] N-substituted piperazinones, in particular, have found application in a diverse range of therapeutic areas,

from anthelmintics like praziquantel to potent anticancer agents such as (-)-agelastatin A.<sup>[2]</sup> The journey of discovering and refining the synthesis of these valuable compounds reflects the broader evolution of synthetic organic chemistry.

## Early Synthetic Strategies: Building the Core

The initial forays into the synthesis of piperazinones were characterized by classical cyclization reactions, often requiring harsh conditions and offering limited scope for substitution.

### Cyclization of Ethylenediamines with $\alpha$ -Haloesters and Related Reagents

One of the earliest and most straightforward approaches to the piperazinone ring involves the reaction of an N-substituted ethylenediamine with an  $\alpha$ -haloester, such as ethyl chloroacetate or ethyl bromoacetate. This two-step process begins with an initial N-alkylation, followed by an intramolecular cyclization to form the lactam ring.<sup>[3]</sup>

- **Causality Behind Experimental Choices:** The use of an excess of the ethylenediamine is often necessary to minimize the formation of the undesired N,N'-dialkylated product. The choice of the base is critical for the cyclization step, with weaker bases like sodium bicarbonate being sufficient to promote intramolecular aminolysis without causing significant ester hydrolysis.

## Experimental Protocol: Synthesis of 1-Benzylpiperazin-2-one

Materials:

- N-Benzylethylenediamine
- Ethyl bromoacetate
- Sodium bicarbonate
- Ethanol
- Diethyl ether

Procedure:

- To a solution of N-benzylethylenediamine (2 equivalents) in ethanol, add sodium bicarbonate (2.2 equivalents).
- Cool the mixture to 0 °C and add ethyl bromoacetate (1 equivalent) dropwise.
- Allow the reaction to warm to room temperature and stir for 24 hours.
- Remove the solvent under reduced pressure.
- Partition the residue between water and diethyl ether.
- Separate the organic layer, dry over anhydrous sodium sulfate, and concentrate in vacuo.
- Purify the crude product by column chromatography on silica gel to afford 1-benzylpiperazin-2-one.

## The Cyanohydrin Route

Another early method involved the reaction of an N,N'-disubstituted ethylenediamine with a cyanohydrin, or a carbonyl compound and hydrogen cyanide. This approach, while effective, utilized highly toxic reagents, limiting its widespread application.[4] A variation of this method, known as the "cyanohydrin acetate synthesis," reacts a substituted 1,2-diamine with a cyanohydrin acetate in the presence of a haloform and an alkali metal hydroxide.[5]

## The Rise of Multicomponent Reactions: Efficiency and Diversity

The demand for rapid access to diverse libraries of piperazinone-containing compounds for high-throughput screening spurred the development of more efficient synthetic strategies. Multicomponent reactions (MCRs), where three or more reactants combine in a single operation to form a product containing substantial portions of all the reactants, emerged as a powerful tool.

## The Ugi and Passerini Reactions

The Ugi four-component reaction (U-4CR) and the related Passerini three-component reaction (P-3CR) are isocyanide-based MCRs that have been ingeniously adapted for the synthesis of piperazinones.[6][7] A "disrupted" Ugi reaction, for instance, can be employed to generate piperazinone scaffolds.[8]

- **Expertise & Experience:** The key to a successful Ugi-based piperazinone synthesis lies in the careful selection of bifunctional starting materials that can undergo the initial MCR followed by a subsequent intramolecular cyclization. For example, using an amino acid as one of the components can lead to a linear intermediate primed for cyclization.

Diagram: Ugi Reaction for Piperazinone Synthesis

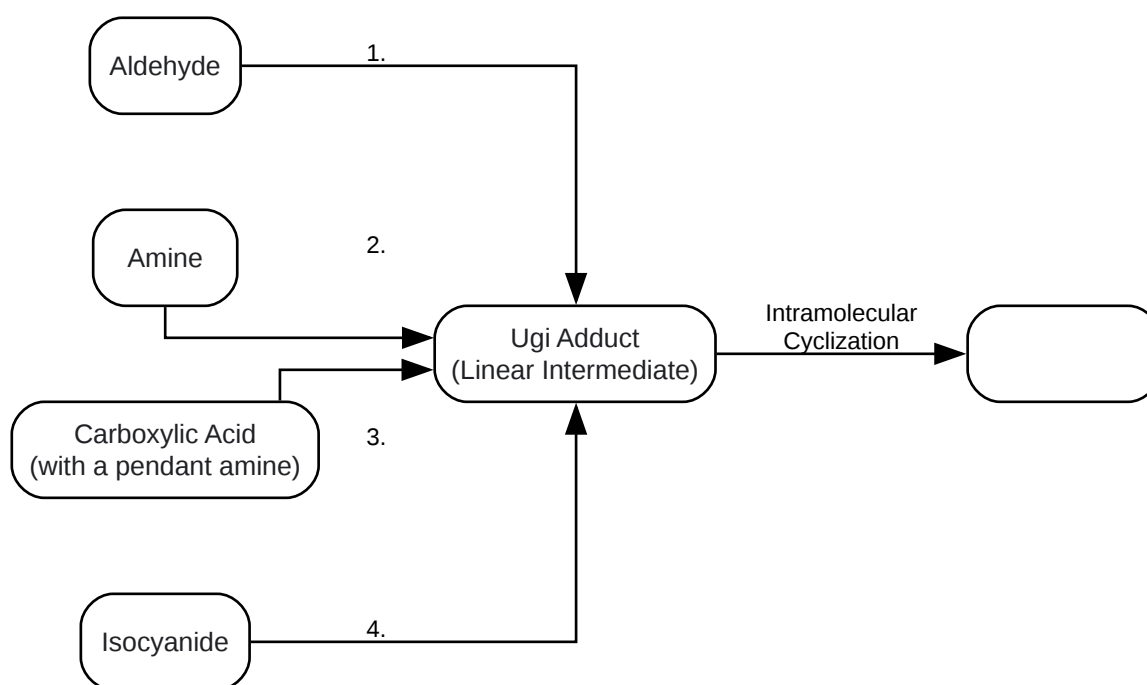

[Click to download full resolution via product page](#)

Caption: A generalized workflow for the Ugi four-component reaction leading to a piperazinone scaffold.

## Modern Catalytic and Asymmetric Approaches

The development of novel catalytic systems has revolutionized the synthesis of N-substituted piperazinones, enabling milder reaction conditions, broader substrate scope, and, crucially, access to enantiomerically pure compounds.

## Palladium-Catalyzed Reactions

Palladium catalysis has been instrumental in the synthesis of both N-aryl and chiral piperazinones.

- N-Arylation: The Buchwald-Hartwig amination allows for the efficient coupling of piperazinones with aryl halides and triflates to furnish N-aryl piperazinones.
- Asymmetric Hydrogenation: Chiral piperazin-2-ones can be accessed with high enantioselectivity through the palladium-catalyzed asymmetric hydrogenation of pyrazin-2-ols.<sup>[2][9]</sup> This method provides a direct route to optically active piperazinones, which are highly sought after in drug development.<sup>[2]</sup>
- Asymmetric Allylic Alkylation: Stoltz and co-workers have developed an elegant palladium-catalyzed asymmetric allylic alkylation for the synthesis of chiral piperazin-2-ones.<sup>[2]</sup>

## Cascade Reactions

Modern synthetic chemistry increasingly focuses on cascade reactions, where a series of transformations occur in a single pot, minimizing waste and improving efficiency. A notable example is a metal-promoted cascade transformation utilizing a chloro allenylamide, a primary amine, and an aryl iodide to afford piperazinones in good yields.<sup>[10][11]</sup> This one-pot process allows for the formation of three new bonds and introduces two points of diversity.<sup>[10][11]</sup>

Diagram: Catalytic Asymmetric Synthesis Workflow

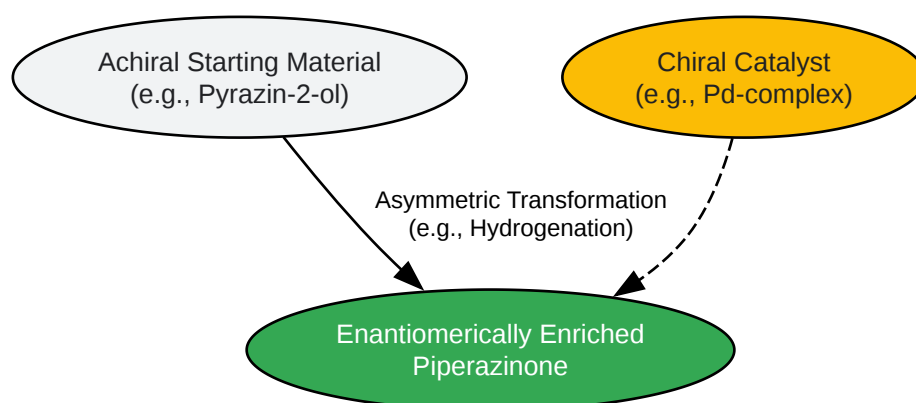

[Click to download full resolution via product page](#)

Caption: General principle of catalytic asymmetric synthesis for producing chiral piperazinones.

## Data Summary

Synthetic Method	Key Reactants	Advantages	Limitations
Classical Cyclization	N-substituted ethylenediamine, $\alpha$ -haloester	Straightforward, readily available starting materials	Often requires excess reagents, limited diversity
Cyanohydrin Route	N,N'-disubstituted ethylenediamine, cyanohydrin	Access to a range of substitution patterns	Use of highly toxic reagents
Ugi Reaction	Aldehyde, amine, carboxylic acid, isocyanide	High efficiency, diversity-oriented	Can require bifunctional starting materials for cyclization
Pd-Catalyzed Asymmetric Hydrogenation	Pyrazin-2-ol, H <sub>2</sub> , chiral Pd-catalyst	High enantioselectivity, direct access to chiral products	Catalyst cost and sensitivity
Cascade Reaction	Chloro allenylamide, primary amine, aryl iodide	High efficiency, multiple bond formation in one pot	May require careful optimization of reaction conditions

## Conclusion and Future Outlook

The synthesis of N-substituted piperazinones has evolved significantly from its early beginnings. The journey from classical cyclization methods to modern catalytic and multicomponent reactions has been driven by the increasing importance of this scaffold in medicinal chemistry. Future developments in this field will likely focus on even more efficient and sustainable synthetic methods, including the use of photoredox catalysis and enzymatic transformations.<sup>[12]</sup> The continued exploration of novel synthetic routes will undoubtedly lead to the discovery of new N-substituted piperazinone-based drugs with improved therapeutic profiles.

## References

- Zhang, J., et al. (2021). Synthesis of chiral piperazin-2-ones through palladium-catalyzed asymmetric hydrogenation of pyrazin-2-ols. *Organic Chemistry Frontiers*. [Link][2][9]
- Meninno, S., et al. (2023). Asymmetric Catalytic Access to Piperazin-2-ones and Morpholin-2-ones in a One-Pot Approach: Rapid Synthesis of an Intermediate to Aprepitant. *The Journal of Organic Chemistry*. [Link][1][13][14]
- Romanelli, M. N., et al. (2023). Synthetic Approaches to Piperazine-Containing Drugs Approved by FDA in the Period of 2011–2023. *Molecules*. [Link][15]
- De Risi, C., et al. (2010). Syntheses and transformations of piperazinone rings. A review.
- Wuts, P. G. M. (n.d.). Ugi and Passerini MCRs. In *Peptidomimetics II*. [Link][6]
- Petkovic, M., et al. (2023). Synthesis of Piperazin-2-one Derivatives via Cascade Double Nucleophilic Substitution. Request PDF. [Link][11]
- Ganem, B. (n.d.). Solid-Phase Synthesis Using the Disrupted Ugi Reaction. [Link][8]
- Zhu, J. (2018). Still Unconquered: Enantioselective Passerini and Ugi Multicomponent Reactions. *Accounts of Chemical Research*. [Link][7]
- D'Hondt, S., et al. (2021).
- Baran, P. S. (2003). The Biginelli and Related (Passerini and Ugi) Reactions. Baran Lab. [Link][17]
- Borg-Warner Corp. (1980). Synthesis of 2-piperazinones and 1,4-diaza-2-ketocycloheptanes.
- Chaudhary, P., et al. (2006). Synthesis and Antimicrobial Activity of N-alkyl and N-aryl Piperazine Derivatives. *Bioorganic & Medicinal Chemistry*. [Link][19]
- Pittelkow, T., & Christensen, J. B. (2024). A Simple Synthesis of N-Alkylpiperazines.
- The Dow Chemical Company. (1990). Preparation of piperazinones for use as sulfur dioxide absorbents.
- Liu, X., et al. (n.d.). A general and convenient synthesis of N-aryl piperazines.
- Corvino, A., et al. (2018). Design, Synthesis and Biological Evaluation of Novel N-Arylpiperazines Containing a 4,5-Dihydrothiazole Ring. *Molecules*. [Link][22]
- Liu, X., et al. (n.d.). A General and Convenient Synthesis of N-Aryl Piperazines.
- CN106117153A - The preparation method of 2 piperazinones. (2016).
- Sepracor Inc. (2008). Method for synthesis of chiral n-arylpiperazines.

### Need Custom Synthesis?

BenchChem offers custom synthesis for rare earth carbides and specific isotopic labeling.

Email: [info@benchchem.com](mailto:info@benchchem.com) or [Request Quote Online](#).

## Sources

- 1. [pubs.acs.org](https://pubs.acs.org) [[pubs.acs.org](https://pubs.acs.org)]
- 2. [lac.dicp.ac.cn](https://lac.dicp.ac.cn) [[lac.dicp.ac.cn](https://lac.dicp.ac.cn)]
- 3. CN106117153A - The preparation method of 2 piperazinones - Google Patents [[patents.google.com](https://patents.google.com)]
- 4. US4980471A - Preparation of piperazinones for use as sulfur dioxide absorbents - Google Patents [[patents.google.com](https://patents.google.com)]
- 5. US4240961A - Synthesis of 2-piperazinones and 1,4-diaza-2-keto-cycloheptanes - Google Patents [[patents.google.com](https://patents.google.com)]
- 6. Ugi and Passerini MCRs - Peptidomimetics II [[ebrary.net](https://ebrary.net)]
- 7. Still Unconquered: Enantioselective Passerini and Ugi Multicomponent Reactions. | Semantic Scholar [[semanticscholar.org](https://semanticscholar.org)]
- 8. Solid-Phase Synthesis Using the Disrupted Ugi Reaction [[ebrary.net](https://ebrary.net)]
- 9. Synthesis of chiral piperazin-2-ones through palladium-catalyzed asymmetric hydrogenation of pyrazin-2-ols - Organic Chemistry Frontiers (RSC Publishing) [[pubs.rsc.org](https://pubs.rsc.org)]
- 10. Synthesis of Piperazin-2-ones - Thieme Chemistry - Georg Thieme Verlag [[thieme.de](https://thieme.de)]
- 11. [researchgate.net](https://researchgate.net) [[researchgate.net](https://researchgate.net)]
- 12. [mdpi.com](https://mdpi.com) [[mdpi.com](https://mdpi.com)]
- To cite this document: BenchChem. [Discovery and history of N-substituted piperazinones]. BenchChem, [2026]. [Online PDF]. Available at: [<https://www.benchchem.com/product/b043009#discovery-and-history-of-n-substituted-piperazinones>]

---

### Disclaimer & Data Validity:

The information provided in this document is for Research Use Only (RUO) and is strictly not intended for diagnostic or therapeutic procedures. While BenchChem strives to provide accurate protocols, we make no warranties, express or implied, regarding the fitness of this product for every specific experimental setup.



**Technical Support:** The protocols provided are for reference purposes. Unsure if this reagent suits your experiment? [[Contact our Ph.D. Support Team for a compatibility check](#)]

**Need Industrial/Bulk Grade?** [Request Custom Synthesis Quote](#)

## BenchChem

Our mission is to be the trusted global source of essential and advanced chemicals, empowering scientists and researchers to drive progress in science and industry.

### Contact

Address: 3281 E Guasti Rd

Ontario, CA 91761, United States

Phone: (601) 213-4426

Email: [info@benchchem.com](mailto:info@benchchem.com)