

# Application Notes and Protocols for Protein Cross-Linking using 6-hydroxyhexyl methanethiosulfonate

**Author:** BenchChem Technical Support Team. **Date:** May 2026

## Compound of Interest

Compound Name:	6-HYDROXYHEXYL METHANETHIOSULFONATE
CAS No.:	212261-98-8
Cat. No.:	B043810

[Get Quote](#)

For: Researchers, scientists, and drug development professionals.

## Introduction: A Strategic Approach to Covalent Protein Capture

In the intricate landscape of proteomics and drug development, the ability to covalently link proteins is paramount for elucidating protein-protein interactions, stabilizing protein complexes for structural analysis, and constructing sophisticated bioconjugates such as antibody-drug conjugates (ADCs). **6-hydroxyhexyl methanethiosulfonate** (6-OH-Hx-MTS) emerges as a strategic tool in this endeavor, offering a unique combination of a thiol-reactive warhead, a flexible spacer arm, and a terminal hydroxyl group. This application note provides an in-depth technical guide to the effective use of 6-OH-Hx-MTS for protein cross-linking, grounded in mechanistic understanding and field-proven methodologies.

# The Chemistry of 6-OH-Hx-MTS: A Trifecta of Functionality

The efficacy of 6-OH-Hx-MTS as a cross-linking agent is rooted in its distinct molecular architecture, which can be dissected into three key components:

- **The Methanethiosulfonate (MTS) Group:** This is the thiol-reactive moiety responsible for forming a covalent bond with the target protein. The MTS group reacts specifically with the free sulfhydryl (thiol) group of cysteine residues, which are often less abundant on protein surfaces than primary amines, allowing for more selective and precise conjugation.[1] The reaction proceeds via a nucleophilic attack of the cysteine thiolate on the sulfur atom of the MTS group, resulting in the formation of a stable disulfide bond and the release of methanesulfinic acid.
- **The Hexyl Spacer Arm:** This six-carbon aliphatic chain provides a flexible spacer of a defined length (approximately 8.8 Å) between the reactive group and the terminal hydroxyl group.[2] The length of the spacer arm is a critical parameter in cross-linking, as it dictates the distance between the conjugated molecules.[3][4] A longer spacer, such as the hexyl group, is particularly advantageous for intermolecular cross-linking, where it can bridge interacting proteins that may not have cysteine residues in immediate proximity.[3]
- **The Terminal Hydroxyl Group:** The presence of a hydroxyl (-OH) group at the terminus of the spacer arm imparts several beneficial properties. Firstly, it increases the hydrophilicity and water solubility of the cross-linker, which is advantageous when working with large biomolecules that are not amenable to organic solvents.[5][6] Secondly, the hydroxyl group can serve as a secondary site for further modification or conjugation, offering the potential for creating more complex bioconjugates.

## Mechanism of Action: Forging the Disulfide Bridge

The cross-linking process with 6-OH-Hx-MTS is a targeted and efficient reaction that hinges on the nucleophilicity of cysteine residues. The fundamental steps are outlined below:

- **Deprotonation of Cysteine:** For the reaction to occur, the thiol group of the cysteine residue must be in its deprotonated, thiolate form ( $S^-$ ), which is a potent nucleophile. This is favored

at a pH slightly above the pKa of the cysteine thiol (typically around 8.5), hence the common use of reaction buffers with a pH between 7.0 and 8.5.

- **Nucleophilic Attack:** The thiolate anion attacks the electrophilic sulfur atom of the methanethiosulfonate group.
- **Disulfide Bond Formation:** This attack leads to the formation of a stable disulfide bond between the protein and the cross-linker, with the concomitant release of the methanesulfinate leaving group.

Diagram of the Reaction Mechanism:

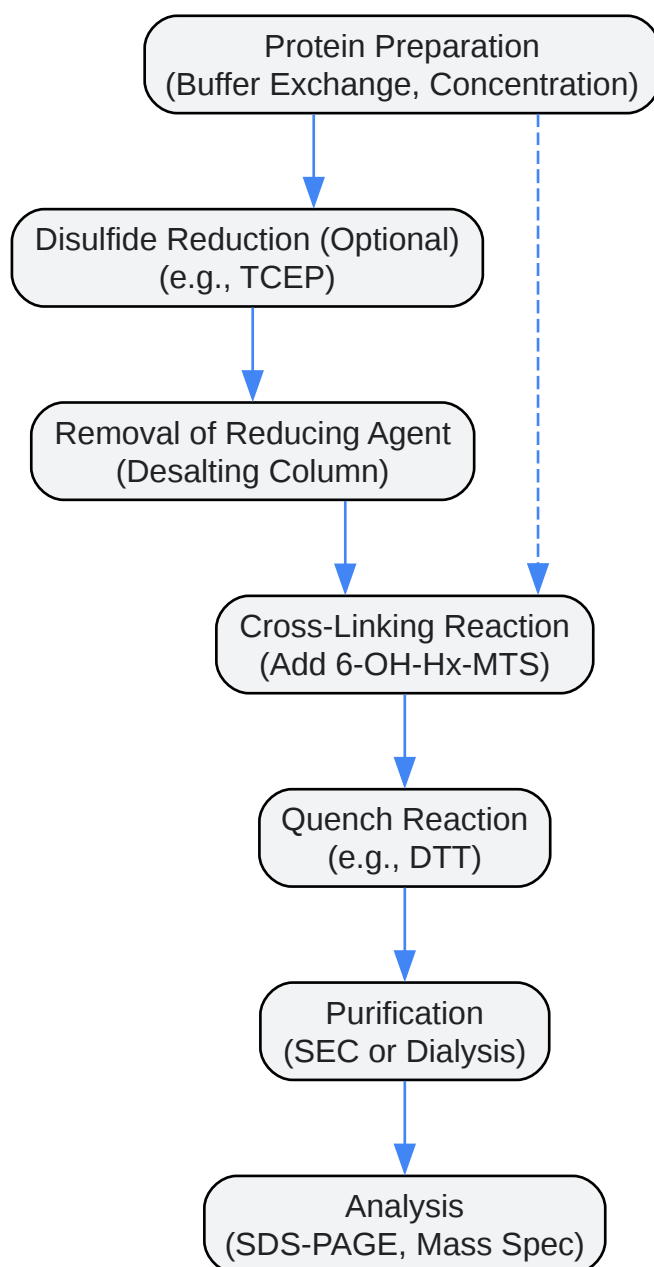
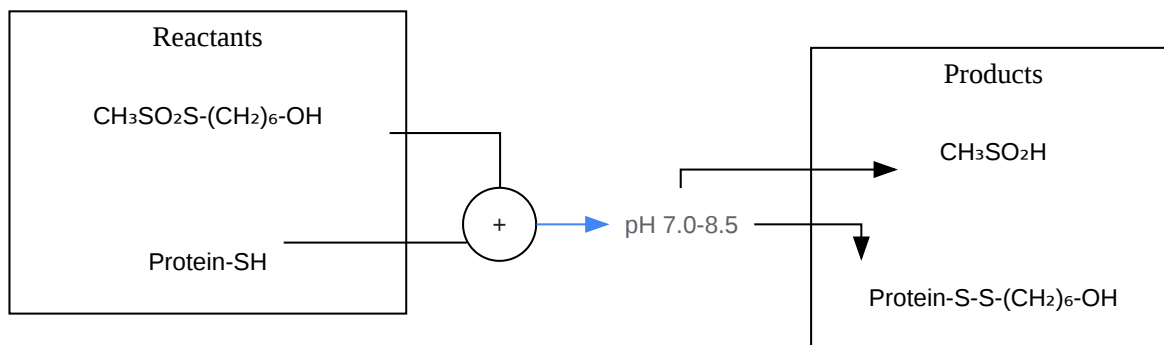

[Click to download full resolution via product page](#)

### Need Custom Synthesis?

BenchChem offers custom synthesis for rare earth carbides and specific isotopic labeling.

Email: [info@benchchem.com](mailto:info@benchchem.com) or [Request Quote Online](#).

## Sources

- [1. Insights on Chemical Crosslinking Strategies for Proteins - PMC \[pmc.ncbi.nlm.nih.gov\]](#)
- [2. The influence of hapten spacer arm length on antibody response and immunoassay development - PubMed \[pubmed.ncbi.nlm.nih.gov\]](#)
- [3. info.gbiosciences.com \[info.gbiosciences.com\]](#)
- [4. The effect of spacer arm length of an adhesion ligand coupled to an alginate gel on the control of fibroblast phenotype - PubMed \[pubmed.ncbi.nlm.nih.gov\]](#)
- [5. Crosslinkers \[sigmaaldrich.com\]](#)
- [6. youtube.com \[youtube.com\]](#)
- To cite this document: BenchChem. [Application Notes and Protocols for Protein Cross-Linking using 6-hydroxyhexyl methanethiosulfonate]. BenchChem, [2026]. [Online PDF]. Available at: [<https://www.benchchem.com/product/b043810/docs#application-notes-and-protocols-for-protein-cross-linking-using-6-hydroxyhexyl-methanethiosulfonate>]

---

### Disclaimer & Data Validity:

The information provided in this document is for Research Use Only (RUO) and is strictly not intended for diagnostic or therapeutic procedures. While BenchChem strives to provide accurate protocols, we make no warranties, express or implied, regarding the fitness of this product for every specific experimental setup.

**Technical Support:** The protocols provided are for reference purposes. Unsure if this reagent suits your experiment?

**Need Industrial/Bulk Grade?** [Request Custom Synthesis Quote](#)

# BenchChem

Our mission is to be the trusted global source of essential and advanced chemicals, empowering scientists and researchers to drive progress in science and industry.

## Contact

Address: 3281 E Guasti Rd  
Ontario, CA 91761, United States  
Phone: (601) 213-4426  
Email: [info@benchchem.com](mailto:info@benchchem.com)

[Contact our Ph.D. Support Team for a compatibility check](#)