

Advanced NMR Characterization of Cis-Proline Derivatives

Author: BenchChem Technical Support Team. **Date:** May 2026

Compound of Interest

Compound Name: *L-Proline, 4-(cyanomethyl)-, cis-*

CAS No.: 119595-96-9

Cat. No.: B043988

[Get Quote](#)

[Application Note & Protocol Guide](#)

Abstract

The cis-trans isomerization of peptidyl-prolyl bonds is a critical determinant in the bioactivity of peptidomimetics and protein folding.^[1] While the trans isomer is thermodynamically dominant in most peptide chains (>99%), the unique cyclic structure of proline stabilizes the cis form, often elevating its population to 10–40% in specific sequences or constrained derivatives. This equilibrium is slow on the NMR timescale, resulting in distinct spectral species that can complicate analysis or, conversely, be exploited for structure-activity relationship (SAR) studies. This guide provides a definitive, self-validating protocol for distinguishing and quantifying cis-proline derivatives using solution-state NMR, centering on the robust

chemical shift diagnostic and NOE connectivity patterns.

Theoretical Foundation: The Proline Switch Thermodynamic Equilibrium and Exchange

Unlike other amino acids where the trans peptide bond is energetically favored by ~2.5 kcal/mol, the energy difference for Xaa-Pro bonds is significantly lower (~0.5 kcal/mol). This is due to the N-alkylated nature of the pyrrolidine ring, which presents similar steric clashes in both cis and trans states.

- Timescale: The interconversion barrier (kcal/mol) results in slow exchange rates ().
- Spectral Consequence: Distinct sets of resonances are observed for cis and trans isomers in NMR spectra, rather than a single averaged peak.[1]

The Diagnostic Logic

To assign the isomers, we rely on two orthogonal physical properties:

- Steric Compression (Shifts): The spatial crowding in the cis isomer shields the -carbon and deshields the -carbon, creating a large chemical shift difference.
- Through-Space Proximity (NOE): The distance between the H of the preceding residue () and the protons of the proline () changes drastically between isomers.

Experimental Protocol

Sample Preparation

- Concentration: 1–5 mM is ideal for -detected experiments.

- Solvent:

or

are preferred to minimize solvent suppression artifacts near H

signals. If amide observation is required, use 90%

/10%

.

- pH Control: Maintain pH 4.0–6.0. High pH (>7.5) can accelerate exchange, potentially broadening peaks.

Data Acquisition Workflow

Perform the following experiments in sequence to build a self-validating dataset.

Step 1: 1D

Screening

- Objective: Quantify the population ratio ().
- Focus Region: 3.5 – 5.0 ppm (H region). Look for peak doubling. The minor isomer (usually cis) often appears as a distinct set of lower-intensity signals.

Step 2: 2D

HSQC (The Gold Standard)

- Objective: Measure and for the "Schubert Analysis" (see Section 3.1).

- Parameters:
 - Spectral width (): 15–70 ppm (aliphatic region).
 - Points: 256 () x 1024 ().
 - Note: Use multiplicity-edited HSQC to distinguish CH and groups if overlap is severe.

Step 3: 2D NOESY / ROESY

- Objective: Spatial verification via connectivity.
- Mixing Time:
 - Small molecules/peptides (< 1.5 kDa): 300–500 ms (NOESY).
 - Mid-sized peptides (1.5–5 kDa): 200–300 ms (ROESY preferred to avoid null NOE).
- Key Observation: Look for vs. cross-peaks.

Data Analysis & Interpretation

The Diagnostic Rule

The most reliable method for assignment is the difference in chemical shift between the Proline and

carbons. This metric, validated by statistical analysis of protein databases (Schubert et al., 2002), is robust against solvent and sequence variations.

Formula:

Isomer	(ppm)	(ppm)	(ppm)	Structural Cause
Trans	29.5 – 32.0	25.0 – 27.5	3.0 – 5.0	Relaxed ring conformation
Cis	32.5 – 35.0	22.0 – 24.5	8.0 – 10.0	Steric compression (gamma-gauche effect)

“

Interpretation: If

ppm, the proline is Cis. If

ppm, the proline is Trans.

NOE Connectivity Patterns

When

data is ambiguous (e.g., severe overlap), NOE patterns provide the definitive geometric proof.

Interaction	Notation	Distance in Trans ()	Distance in Cis ()	Diagnostic Signal
Alpha-Alpha		~4.5 (Weak/None)	~2.2 (Strong)	CIS Marker
Alpha-Delta		~2.2 (Strong)	~4.5 (Weak/None)	TRANS Marker

Visualization of Signaling & Logic

Diagram 1: Isomerization Logic & NOE Distances

This diagram illustrates the structural equilibrium and the specific NOE distances used for assignment.

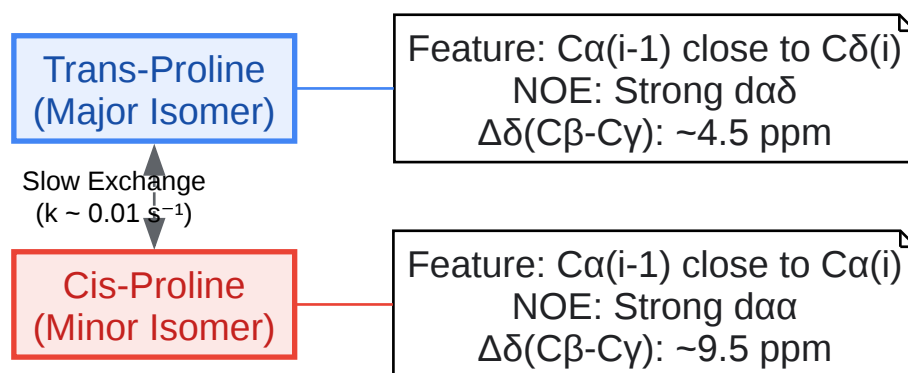

[Click to download full resolution via product page](#)

Caption: Equilibrium between Trans and Cis isomers showing the distinct NOE distances and chemical shift signatures defining each state.

Diagram 2: Assignment Decision Tree

A step-by-step workflow for assigning the isomer based on experimental data.

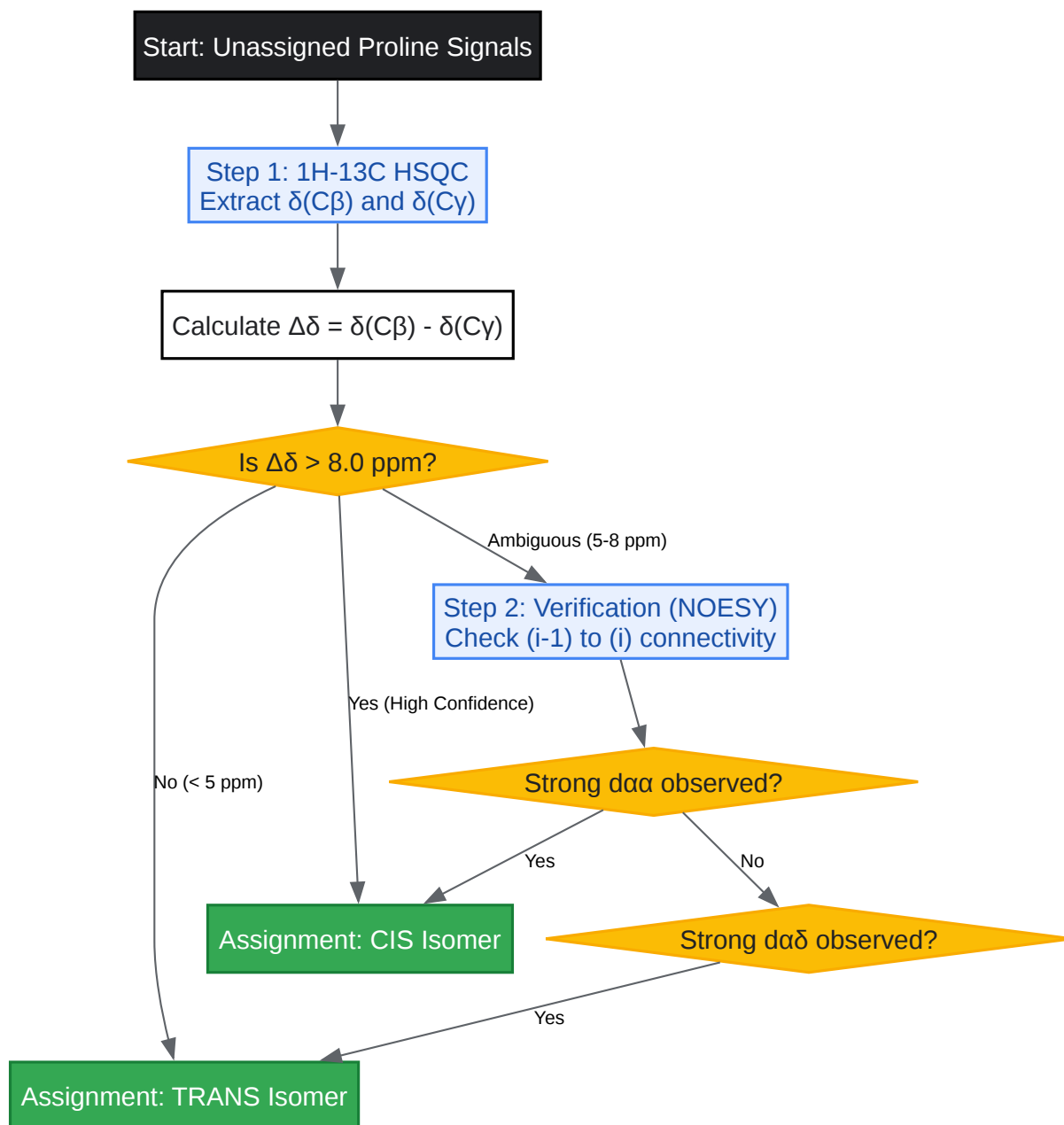

[Click to download full resolution via product page](#)

Caption: Logical workflow for assigning Proline isomers using Carbon-13 chemical shift differences followed by NOE verification.

Troubleshooting & Tips

- Exchange Broadening: If peaks are broad or missing, the isomerization rate may be intermediate (coalescence). Lower the temperature (e.g., to 278 K) to slow the exchange and sharpen the signals.
- Overlap: In proline-rich peptides,

and

regions can be crowded. Use a (H)CC(CO)NH TOCSY experiment if the peptide is labeled to link side-chain carbons to the specific backbone amide of the next residue.
- Quantification: Always integrate the H

or H

protons in the 1D spectrum for quantification, as HSQC peak volumes can be distorted by differences in coupling constants and relaxation times (

) between isomers.

References

- Schubert, M., Labudde, D., Oschkinat, H., & Schmieder, P. (2002). A software tool for the prediction of Xaa-Pro peptide bond conformations in proteins based on ^{13}C chemical shift statistics. *Journal of Biomolecular NMR*, 24, 149–154.[2]
- Wüthrich, K. (1986). *NMR of Proteins and Nucleic Acids*. Wiley-Interscience.

vs

rules).
- Shen, Y., & Bax, A. (2010). SPARTA+: a optimized prediction of protein backbone chemical shifts from primary and secondary structure. *Journal of Biomolecular NMR*, 48(1), 13-22.

- Exarchos, K. P., et al. (2011). Detection of cis/trans-proline isomerization in proteins by NMR spectroscopy. *Biochemical Society Transactions*, 39, 538-542.

Need Custom Synthesis?

BenchChem offers custom synthesis for rare earth carbides and specific isotopic labeling.

Email: info@benchchem.com or [Request Quote Online](#).

Sources

- [1. imrpress.com \[imrpress.com\]](http://imrpress.com)
- [2. Proline cis-trans isomerization controls autoinhibition of a signaling protein - PMC \[pmc.ncbi.nlm.nih.gov\]](http://pmc.ncbi.nlm.nih.gov)
- To cite this document: BenchChem. [Advanced NMR Characterization of Cis-Proline Derivatives]. BenchChem, [2026]. [Online PDF]. Available at: [\[https://www.benchchem.com/product/b043988/docs#advanced-nmr-characterization-of-cis-proline-derivatives\]](https://www.benchchem.com/product/b043988/docs#advanced-nmr-characterization-of-cis-proline-derivatives)

Disclaimer & Data Validity:

The information provided in this document is for Research Use Only (RUO) and is strictly not intended for diagnostic or therapeutic procedures. While BenchChem strives to provide accurate protocols, we make no warranties, express or implied, regarding the fitness of this product for every specific experimental setup.

Technical Support: The protocols provided are for reference purposes. Unsure if this reagent suits your experiment?

Need Industrial/Bulk Grade? [Request Custom Synthesis Quote](#)

BenchChem

Our mission is to be the trusted global source of essential and advanced chemicals, empowering scientists and researchers to drive progress in science and industry.

Contact

Address: 3281 E Guasti Rd
Ontario, CA 91761, United States
Phone: (601) 213-4426
Email: info@benchchem.com

[Contact our Ph.D. Support Team for a compatibility check](#)