

# Technical Support Center: Polymerization of Substituted Thiophenes

**Author:** BenchChem Technical Support Team. **Date:** May 2026

## Compound of Interest

Compound Name: *4,5-Dibromothiophene-3-carboxylic acid*

CAS No.: *101079-66-7*

Cat. No.: *B428572*

[Get Quote](#)

Welcome to the technical support center for the synthesis of substituted polythiophenes. This guide is designed for researchers, chemists, and material scientists who are navigating the complexities of polymerizing thiophene derivatives. Polythiophenes are a cornerstone of organic electronics, but their synthesis can be fraught with challenges that impact polymer properties and device performance.

This center provides field-proven insights and solutions to common experimental hurdles. We will delve into the causality behind these challenges and offer robust, self-validating protocols to enhance the reliability and reproducibility of your work.

## Troubleshooting Guide

This section addresses the most frequent and critical issues encountered during the polymerization of substituted thiophenes. Each problem is analyzed from a mechanistic standpoint to provide a foundational understanding for effective troubleshooting.

### Problem: Low Yield or No Polymer Formation

A low or negligible yield of the target polymer is one of the most common frustrations in polymer synthesis. The root causes often trace back to reagent purity, catalyst activity, or suboptimal reaction conditions.

#### Potential Causes & Solutions:

- **Monomer Impurity:** The purity of the thiophene monomer is paramount. Halogenated impurities can interfere with catalyst activity, while protic impurities (e.g., water, alcohols) can quench the organometallic intermediates essential for chain growth, especially in Grignard Metathesis (GRIM) polymerization.
  - **Solution:** Purify the monomer immediately before use through distillation, recrystallization, or column chromatography. Ensure all glassware is rigorously dried and the reaction is conducted under an inert atmosphere (e.g., Argon or Nitrogen).[1]
- **Inactive Catalyst or Base:** The catalyst, whether a Nickel or Palladium complex, is the heart of the polymerization. Catalysts can degrade upon exposure to air or moisture. Similarly, bases used in methods like Direct (Hetero)arylation Polymerization (DHAP) can lose their potency.
  - **Solution:** Use fresh, high-purity catalysts. For air-sensitive catalysts, handle them in a glovebox. If catalyst deactivation is suspected, consider increasing the catalyst loading or using a more robust ligand system.[2]
- **Poor Solvent Quality:** Solvents must be anhydrous and free of inhibitors. For instance, commercial chloroform often contains ethanol as a stabilizer, which can interfere with oxidative polymerizations.[3]
  - **Solution:** Use anhydrous solvents from a solvent purification system or freshly distilled solvents. For  $\text{FeCl}_3$  polymerizations, ensure the solvent is appropriate for both the oxidant and the growing polymer to prevent premature precipitation.[3]
- **Incorrect Reaction Temperature:** Many polymerization reactions have an optimal temperature range. For instance, the initial metal-halogen exchange step in the McCullough or Rieke methods often requires cryogenic temperatures to prevent side reactions.[4]

- Solution: Carefully control the reaction temperature at each step. For exothermic reactions, ensure adequate cooling to prevent runaway reactions that can lead to broader polydispersity or side products.

## Problem: Poor Regioregularity (Low Head-to-Tail Content)

Regioregularity, the specific orientation of substituted thiophene units in the polymer chain, is critical for achieving high charge carrier mobility and desirable optoelectronic properties.<sup>[5][6]</sup> Irregular head-to-head (HH) and tail-to-tail (TT) couplings introduce steric hindrance, forcing the polymer backbone to twist and disrupting  $\pi$ -conjugation.<sup>[6][7]</sup>

Potential Causes & Solutions:

- Choice of Polymerization Method: Oxidative polymerization with agents like  $\text{FeCl}_3$  is convenient but typically yields regiorregular polymers because the coupling mechanism is not highly selective.<sup>[8]</sup>
  - Solution: Employ regioselective polymerization methods like Grignard Metathesis (GRIM) or Stille coupling. The GRIM method, in particular, is known to produce poly(3-alkylthiophene)s (P3ATs) with very high head-to-tail (HT) content (>95%).<sup>[5][9]</sup>
- Steric Hindrance and Catalyst Choice (GRIM Method): In GRIM polymerization, the high regioselectivity arises from the catalyst's preference for the less sterically hindered 2-bromo-3-alkyl-5-magnesiated thiophene intermediate over its more hindered regioisomer.<sup>[9][10]</sup>
  - Solution: The use of  $\text{Ni}(\text{dppp})\text{Cl}_2$  as a catalyst is well-established for promoting high HT coupling.<sup>[9]</sup> The bulky phosphine ligands on the nickel center play a crucial role in directing the regioselective coupling.
- Reaction Conditions: Even in regioselective methods, suboptimal conditions can reduce HT content. Factors like temperature and monomer concentration can influence the selectivity of the catalyst.<sup>[8]</sup>
  - Solution: Adhere to established protocols for the chosen method. For oxidative polymerizations, using lower temperatures and slower monomer addition can sometimes improve regioregularity.<sup>[3][8]</sup>

## Visualization: Regioregular vs. Regiorandom Polythiophene

The diagram below illustrates the structural difference between a highly ordered, regioregular (Head-to-Tail) poly(3-alkylthiophene) and a disordered, regiorandom polymer containing a mix of couplings.

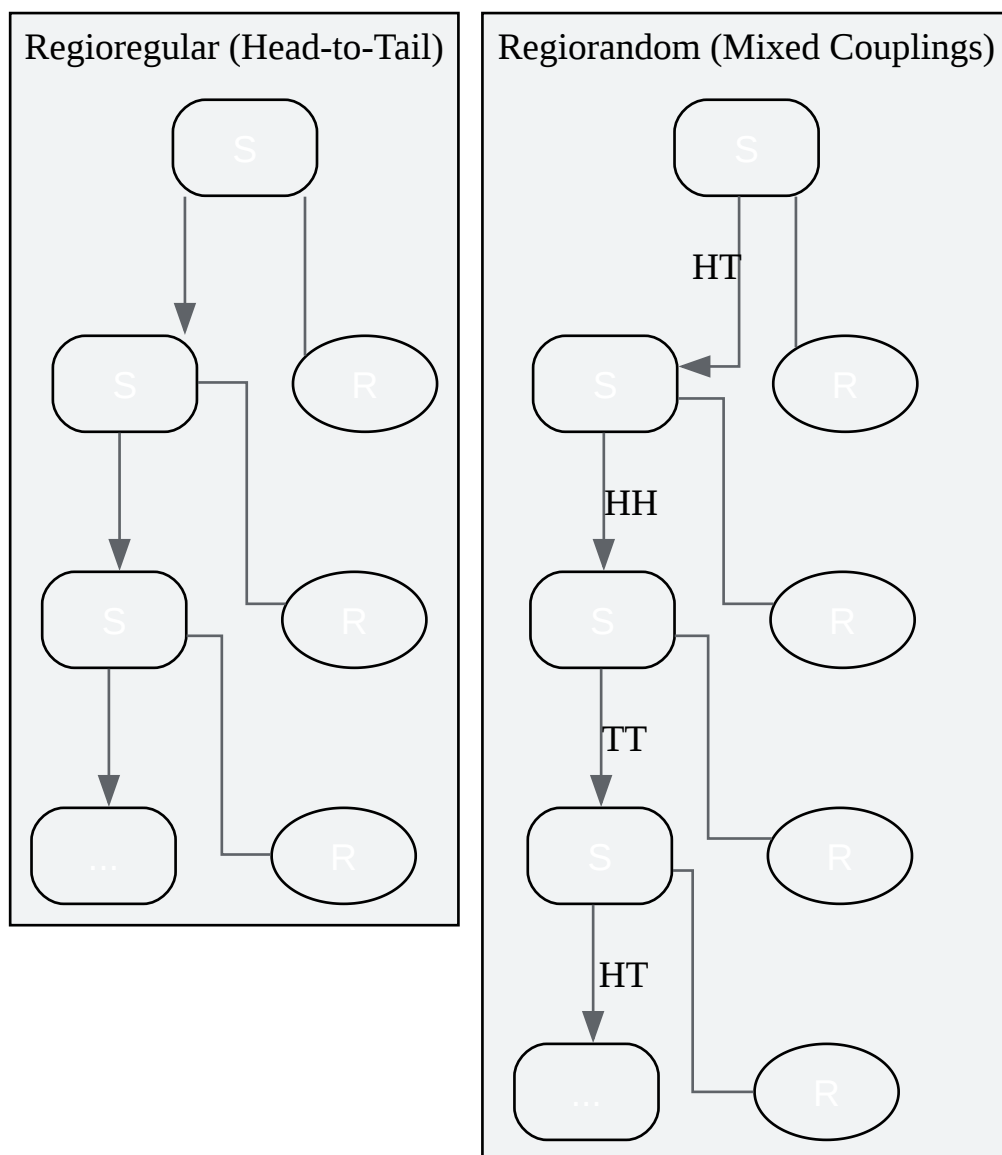

[Click to download full resolution via product page](#)

Caption: Regioregular (RR) vs. Regiorandom (RA) Polythiophene Structure.

## Problem: Uncontrolled Molecular Weight and Broad Polydispersity (PDI)

Control over molecular weight ( $M_n$ ) and achieving a narrow molecular weight distribution (PDI) is essential for consistent material properties and device performance.<sup>[11]</sup> High PDI indicates a mixture of long and short polymer chains, which can negatively affect morphology and charge transport.

Potential Causes & Solutions:

- **Polymerization Mechanism:** Step-growth polymerizations (e.g., Stille, Suzuki) inherently produce polymers with broader PDIs (typically  $\sim 2.0$ ) and make it harder to target a specific molecular weight.<sup>[12]</sup>
  - **Solution:** Utilize a chain-growth polymerization method. GRIM polymerization exhibits characteristics of a living polymerization, allowing for the synthesis of polymers with predictable molecular weights (controlled by the monomer-to-initiator ratio) and narrower PDIs (typically 1.2-1.5).<sup>[13][14]</sup>
- **Chain Termination/Transfer Reactions:** Impurities, high temperatures, or side reactions can prematurely terminate growing polymer chains, leading to lower molecular weights and broader PDI.
  - **Solution:** Ensure high purity of all reagents and solvents.<sup>[1]</sup> Maintain strict control over the reaction temperature. In GRIM polymerizations, the choice of Grignard reagent for the initial metathesis can also play a role.
- **Slow Initiation:** If the rate of initiation is slow compared to the rate of propagation, it can lead to a broader PDI.
  - **Solution:** Ensure the catalyst is added quickly and efficiently to the activated monomer solution to synchronize the start of polymer chain growth.

## Frequently Asked Questions (FAQs)

Q1: Which polymerization method is best for my substituted thiophene?

The best method depends on your specific goals regarding regioselectivity, molecular weight control, monomer availability, and scale.

Method	Key Advantages	Key Disadvantages	Best For
Oxidative (FeCl <sub>3</sub> )	Simple, inexpensive, scalable.[3]	Poor control over regioselectivity and MW.[8]	Bulk synthesis where high regioselectivity is not critical.
Stille/Suzuki Coupling	Versatile for co-polymers.	Step-growth (broad PDI), toxic tin reagents (Stille).[12]	Creating complex co-polymers with various aromatic units.
GRIM Polymerization	High regioselectivity, chain-growth (controlled MW, narrow PDI), room temperature reaction. [4][13]	Requires careful handling of Grignard reagents, sensitive to impurities.	High-performance, regioselective homopolymers like P3HT.
Direct Arylation (DHAP)	Atom-economical (fewer pre-activation steps).	Can be sensitive to monomer C-H acidity, potential for side reactions.[2]	"Greener" synthesis routes, avoiding organometallic intermediates.

Q2: What are the critical factors for achieving high regioselectivity in GRIM polymerization?

Success in GRIM polymerization hinges on controlling the initial metal-halogen exchange and the subsequent catalyst-driven coupling.

- **Monomer Quality:** Start with high-purity 2,5-dihalo-3-alkylthiophene.
- **Grignard Exchange:** The reaction of the monomer with an alkylmagnesium halide (e.g., *t*-butylmagnesium chloride) creates a mixture of two magnesiated regioisomers. This step is crucial for activating the monomer.[4]
- **Catalyst Choice:** Ni(dppp)Cl<sub>2</sub> is the standard and highly effective catalyst. Its steric bulk selectively polymerizes the less hindered regioisomer, driving the reaction towards high HT

content.[9][10]

- Inert Conditions: The Grignard intermediates are extremely sensitive to air and moisture. The entire process must be conducted under a dry, inert atmosphere.

### Visualization: Simplified GRIM Polymerization Mechanism

This diagram outlines the key steps in the chain-growth mechanism of GRIM polymerization.

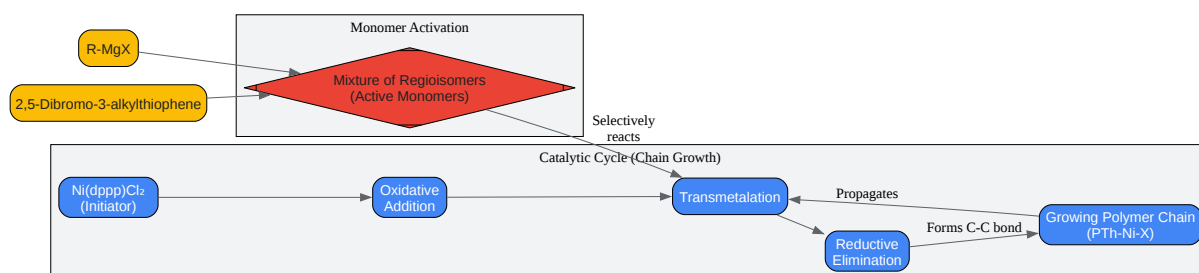

[Click to download full resolution via product page](#)

Caption: Key steps of the GRIM polymerization process.

Q3: How can I effectively remove the metal catalyst from the final polymer?

Residual catalyst (Ni or Pd) can quench luminescence and negatively impact electronic properties. Thorough purification is essential.

- Precipitation: After polymerization, the reaction is typically quenched with an acid (e.g., HCl). The polymer is then precipitated in a non-solvent like methanol, which helps remove some catalyst salts.

- **Soxhlet Extraction:** This is the most common and effective method. The crude polymer is placed in a Soxhlet thimble and continuously washed with a series of solvents. A typical sequence is:
  - **Methanol:** To remove polar impurities and salts.
  - **Hexane/Heptane:** To remove oligomers and unreacted monomer.
  - **Chloroform/THF:** To dissolve and collect the pure polymer, leaving insoluble catalyst residues behind in the thimble.
- **Complexing Agents/Scavengers:** For very low catalyst levels, the polymer solution can be washed with an aqueous solution of a chelating agent like EDTA. Alternatively, stirring the polymer solution with a solid-supported scavenger (e.g., functionalized silica gel) can bind and remove residual metal, which is then filtered off.<sup>[15][16]</sup>

Q4: My polymer is insoluble after synthesis. What can I do?

Insolubility usually points to either extremely high molecular weight or cross-linking side reactions.

- **Assess Molecular Weight:** Use Gel Permeation Chromatography (GPC) if a small fraction is soluble. If the molecular weight is excessively high, you can reduce it by increasing the initiator-to-monomer ratio in future syntheses.
- **Check for Cross-linking:** This can occur at high temperatures or if the monomer has reactive sites other than the 2 and 5 positions of the thiophene ring. Re-evaluate your reaction conditions, particularly temperature and reaction time.
- **Solvent Choice:** Polythiophenes with shorter alkyl chains (e.g., poly(3-butylthiophene)) are less soluble than those with longer chains (e.g., poly(3-hexylthiophene)). Try dissolving the polymer in higher boiling point solvents like dichlorobenzene or trichlorobenzene with gentle heating.

## Key Protocols

## Example Protocol: Regioregular P3HT Synthesis via GRIM Polymerization

This is a generalized procedure and should be adapted based on specific lab conditions and safety protocols.

- **Setup:** Assemble a flame-dried, three-neck flask equipped with a condenser, magnetic stirrer, and argon inlet.
- **Monomer Activation:** Under a positive argon flow, add 2,5-dibromo-3-hexylthiophene (1.0 eq) and anhydrous THF to the flask. Cool the solution to 0°C. Add tert-butyilmagnesium chloride (1.0 M in THF, 1.0 eq) dropwise over 15 minutes. Stir the mixture at room temperature for 1-2 hours.
- **Polymerization:** In a separate, dry flask, dissolve Ni(dppp)Cl<sub>2</sub> (0.01-0.02 eq) in a small amount of anhydrous THF. Add the catalyst solution to the monomer solution via cannula. The solution should darken, indicating the start of polymerization. Let the reaction proceed at room temperature for 2-4 hours.
- **Quenching & Precipitation:** Quench the reaction by slowly adding 5M HCl. Stir for 30 minutes. Pour the mixture into a beaker of methanol. The polymer should precipitate as a dark solid.
- **Purification:** Filter the crude polymer and wash with methanol. Dry the solid and perform a Soxhlet extraction with methanol, then hexane, and finally collect the polymer by extracting with chloroform.
- **Final Step:** Evaporate the chloroform and dry the final polymer under vacuum. Characterize by <sup>1</sup>H NMR (for regioregularity), GPC (for Mn and PDI), and UV-Vis spectroscopy.

## References

- Sista, P., & Stefan, M. C. (2012). Grignard metathesis (GRIM) method for the synthesis of regioregular poly(3-alkylthiophene)s with well-defined molecular weights. *Polymer Chemistry*, 3(7), 1693-1701. [[Link](#)]

- McCullough, R. D., & Loewe, R. S. (2001). Regioregular, Head-to-Tail Coupled Poly(3-alkylthiophenes) Made Easy by the GRIM Method: Investigation of the Reaction and the Origin of Regioselectivity. *Macromolecules*, 34(9), 2997-3004. [[Link](#)]
- Henderson, K. J., et al. (2021). Enabling Conducting Polymer Applications: Methods for Achieving High Molecular Weight in Chemical Oxidative Polymerization in Alkyl- and Ether-Substituted Thiophenes. *Polymers*, 13(20), 3568. [[Link](#)]
- Roy, A., et al. (2020). Recent developments in the synthesis of regioregular thiophene-based conjugated polymers for electronic and optoelectronic applications using nickel and palladium-based catalytic systems. *RSC Advances*, 10(7), 3983-4031. [[Link](#)]
- Jeffries-EL, M., et al. (n.d.). Grignard Metathesis (GRIM) Method for the Synthesis of Regioregular Poly(3-alkylthiophenes) with Well-Defined Molecular Weights. Carnegie Mellon University. [[Link](#)]
- Sheina, E. E., et al. (2004). Experimental Evidence for the Quasi-“Living” Nature of the Grignard Metathesis Method for the Synthesis of Regioregular Poly(3-alkylthiophenes). *Macromolecules*, 37(10), 3526-3528. [[Link](#)]
- Loewe, R. S., et al. (2001). Regioregular, Head-to-Tail Coupled Poly(3-alkylthiophenes) Made Easy by the GRIM Method: Investigation of the Reaction and the Origin of Regioselectivity. Carnegie Mellon University. [[Link](#)]
- Matyjaszewski Polymer Group. (n.d.). Catalyst Removal. Carnegie Mellon University. [[Link](#)]
- Bahri-Laleh, N., et al. (2018). Exploring the mechanism of Grignard metathesis polymerization of 3-alkylthiophenes. *Dalton Transactions*, 47(2), 558-568. [[Link](#)]
- McCullough Group. (n.d.). Regioregular Poly(3-alkylthiophene). Carnegie Mellon University. [[Link](#)]
- Beaupré, S., et al. (2023). Toward Defect Suppression in Polythiophenes Synthesized by Direct (Hetero)Arylation Polymerization. *Macromolecules*, 56(5), 1869-1883. [[Link](#)]
- Chemistry For Everyone. (2025). What Is The Best Way To Remove Polymerization Catalysts? YouTube. [[Link](#)]

- Zosa, M. D., et al. (2022). Removal of photoredox catalysts from polymers synthesized by organocatalyzed atom transfer radical polymerization. *Journal of Polymer Science*, 60(18), 2748-2756. [[Link](#)]
- Kumar, A., et al. (2018). Synthesis and characterization of poly(3-hexylthiophene): improvement of regioregularity and energy band gap. *Heliyon*, 4(2), e00533. [[Link](#)]
- Polymer Engineering. (2020). Molecular Weight's Effect On Polymer Properties. YouTube. [[Link](#)]

### Need Custom Synthesis?

BenchChem offers custom synthesis for rare earth carbides and specific isotopic labeling.

Email: [info@benchchem.com](mailto:info@benchchem.com) or [Request Quote Online](#).

## Sources

- 1. [pdf.benchchem.com](https://pdf.benchchem.com) [[pdf.benchchem.com](https://pdf.benchchem.com)]
- 2. [pubs.acs.org](https://pubs.acs.org) [[pubs.acs.org](https://pubs.acs.org)]
- 3. Enabling Conducting Polymer Applications: Methods for Achieving High Molecular Weight in Chemical Oxidative Polymerization in Alkyl- and Ether-Substituted Thiophenes - PMC [[pmc.ncbi.nlm.nih.gov](https://pmc.ncbi.nlm.nih.gov)]
- 4. [researchgate.net](https://researchgate.net) [[researchgate.net](https://researchgate.net)]
- 5. [chem.cmu.edu](https://chem.cmu.edu) [[chem.cmu.edu](https://chem.cmu.edu)]
- 6. The McCullough Group - Research [[chem.cmu.edu](https://chem.cmu.edu)]
- 7. Facile Preparation of High-Performance Polythiophene Derivative and Effect of Torsion Angle Between Thiophene Rings on Electrochromic Color Change [[mdpi.com](https://mdpi.com)]
- 8. Synthesis and characterization of poly(3-hexylthiophene): improvement of regioregularity and energy band gap - PMC [[pmc.ncbi.nlm.nih.gov](https://pmc.ncbi.nlm.nih.gov)]
- 9. [pubs.acs.org](https://pubs.acs.org) [[pubs.acs.org](https://pubs.acs.org)]
- 10. Exploring the mechanism of Grignard metathesis polymerization of 3-alkylthiophenes - Dalton Transactions (RSC Publishing) [[pubs.rsc.org](https://pubs.rsc.org)]
- 11. [youtube.com](https://youtube.com) [[youtube.com](https://youtube.com)]

- [12. Recent developments in the synthesis of regioregular thiophene-based conjugated polymers for electronic and optoelectronic applications using nickel a ... - RSC Advances \(RSC Publishing\) DOI:10.1039/C9RA09712K \[pubs.rsc.org\]](#)
- [13. chem.cmu.edu \[chem.cmu.edu\]](#)
- [14. files01.core.ac.uk \[files01.core.ac.uk\]](#)
- [15. Catalyst Removal - Matyjaszewski Polymer Group - Carnegie Mellon University \[cmu.edu\]](#)
- [16. m.youtube.com \[m.youtube.com\]](#)
- To cite this document: BenchChem. [Technical Support Center: Polymerization of Substituted Thiophenes]. BenchChem, [2026]. [Online PDF]. Available at: [\[https://www.benchchem.com/product/b428572/docs#technical-support-center-polymerization-of-substituted-thiophenes\]](https://www.benchchem.com/product/b428572/docs#technical-support-center-polymerization-of-substituted-thiophenes)

---

### Disclaimer & Data Validity:

The information provided in this document is for Research Use Only (RUO) and is strictly not intended for diagnostic or therapeutic procedures. While BenchChem strives to provide accurate protocols, we make no warranties, express or implied, regarding the fitness of this product for every specific experimental setup.

**Technical Support:** The protocols provided are for reference purposes. Unsure if this reagent suits your experiment?

**Need Industrial/Bulk Grade?** [Request Custom Synthesis Quote](#)

## BenchChem

Our mission is to be the trusted global source of essential and advanced chemicals, empowering scientists and researchers to drive progress in science and industry.

### Contact

Address: 3281 E Guasti Rd  
Ontario, CA 91761, United States  
Phone: (601) 213-4426  
Email: [info@benchchem.com](mailto:info@benchchem.com)

Contact our Ph.D. Support Team for a compatibility check