

Preparation of Sulfonamides Using *p*-Toluenesulfonyl Chloride: A Technical Guide

Author: BenchChem Technical Support Team. **Date:** December 2025

Compound of Interest

Compound Name: *p*-Toluenesulfonyl chloride

Cat. No.: B042831

[Get Quote](#)

For Researchers, Scientists, and Drug Development Professionals

This in-depth technical guide provides a comprehensive overview of the synthesis of sulfonamides utilizing ***p*-toluenesulfonyl chloride** (TsCl). The document details the fundamental reaction, experimental protocols for various substrates, quantitative data on reaction yields, and the relevance of sulfonamides in drug development, particularly as enzyme inhibitors.

Introduction to Sulfonamide Synthesis

The reaction of ***p*-toluenesulfonyl chloride** with primary or secondary amines is a cornerstone of sulfonamide synthesis. This nucleophilic substitution reaction, often referred to as tosylation, results in the formation of a stable sulfonamide bond. The general reaction proceeds as follows:

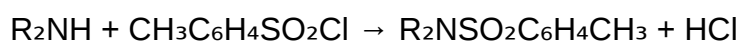
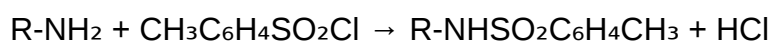

The reaction is typically carried out in the presence of a base, such as pyridine or triethylamine, to neutralize the hydrochloric acid byproduct. The versatility of this reaction allows for the synthesis of a wide array of sulfonamides by varying the amine starting material.

Reaction Mechanism and Logical Workflow

The synthesis of sulfonamides from **p-toluenesulfonyl chloride** follows a well-established nucleophilic acyl substitution-like mechanism. The amine acts as a nucleophile, attacking the electrophilic sulfur atom of the sulfonyl chloride. This is followed by the departure of the chloride leaving group.

A logical workflow for a typical sulfonamide synthesis experiment is outlined below. This workflow highlights the key stages from reaction setup to product isolation and purification.

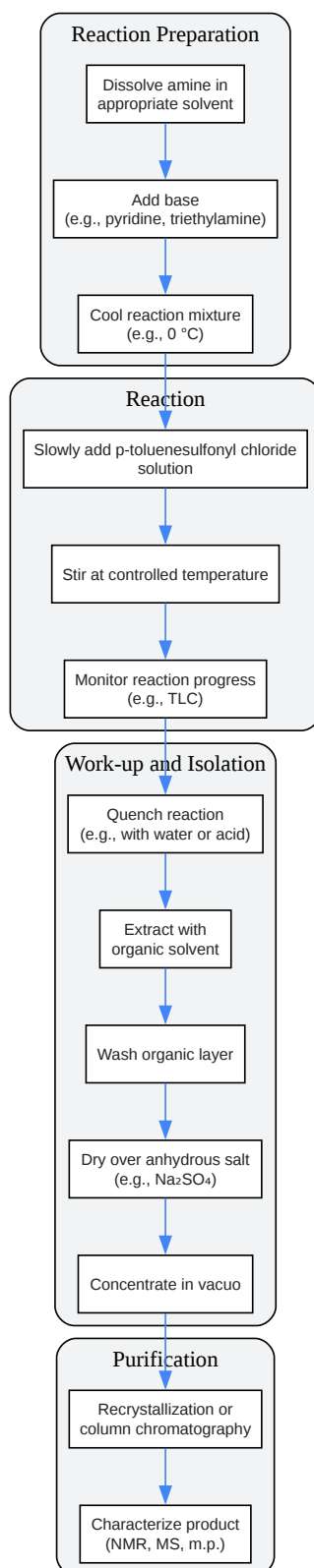

[Click to download full resolution via product page](#)

Caption: General experimental workflow for sulfonamide synthesis.

Quantitative Data Summary

The following tables summarize yields for the synthesis of various sulfonamides from **p-toluenesulfonyl chloride** and different amines under specific reaction conditions.

Table 1: Synthesis of N-Aryl and N-Alkyl Sulfonamides

Amine	Base	Solvent	Reaction Time (h)	Temperature (°C)	Yield (%)	Reference
Aniline	Pyridine	THF	6	Room Temp.	86	[1]
p-Toluidine	Pyridine	-	-	0-25	Quantitative	[1]
4-Nitroaniline	Pyridine	-	-	0-25	High	[2]
Methylamine (33% aq.)	Sodium Hydroxide	Water	0.5	80-90	85-90	[3]
Benzylamine	Triethylamine	Dichloromethane	-	0	-	[4]
Allylamine	Potassium Carbonate	THF/Water	24	Room Temp.	-	[5]
4-Methylbenzylamine	Pyridine	Dichloromethane	24	Room Temp.	42	[2]

Table 2: Synthesis of Sulfonamides from Amino Acids

Amino Acid Derivative	Base	Solvent	Reaction Time	Temperature	Yield (%)	Reference
Nicotinamide	Sodium Carbonate	Water	-	-	-	[6]
Tryptophan	Sodium Carbonate	Water	-	-	-	[6]
Tranexamic acid	Sodium Carbonate	Water	-	-	-	[6]

Detailed Experimental Protocols

General Procedure for the Synthesis of N-Substituted-p-toluenesulfonamides

To a solution of the amine (1.0 eq) and a suitable base (1.1-1.5 eq, e.g., triethylamine or pyridine) in an anhydrous solvent (e.g., dichloromethane or THF) at 0 °C is added a solution of **p-toluenesulfonyl chloride** (1.05-1.1 eq) in the same solvent dropwise. The reaction mixture is then allowed to warm to room temperature and stirred for a period of 2 to 24 hours, with the progress monitored by thin-layer chromatography (TLC). Upon completion, the reaction is quenched with water or a dilute acid solution. The product is extracted into an organic solvent, and the organic layer is washed successively with dilute acid, saturated sodium bicarbonate solution, and brine. The organic layer is then dried over anhydrous sodium sulfate, filtered, and concentrated under reduced pressure. The crude product can be purified by recrystallization or column chromatography on silica gel.[7]

Synthesis of N-(4-Methylbenzyl)-4-methylbenzenesulfonamide[2]

In a round-bottom flask, 4-methylbenzylamine (0.75 mL, 5.90 mmol) and pyridine (0.48 mL, 5.90 mmol) were dissolved in 10 mL of degassed dichloromethane under a nitrogen atmosphere. To this stirring mixture, **p-toluenesulfonyl chloride** (1.00 g, 5.25 mmol) was added dropwise. The reaction was stirred at room temperature for 24 hours. The mixture was

then acidified with 5 M HCl and diluted with 15 mL of dichloromethane. The organic phase was separated and washed with water. The aqueous layers were combined and back-extracted with 10 mL of dichloromethane. The combined organic layers were dried over anhydrous sodium sulfate and evaporated to dryness. The resulting residue was dissolved in hot ethanol and filtered. Upon standing for 24 hours, pale-yellow crystals of the product formed and were filtered from the mother liquor. The yield was 42% with a melting point of 376–378 K.[2]

Synthesis of Sulfonamides from Amino Acids in Aqueous Media[6]

The amino acid or its analog is dissolved in distilled water with constant stirring. The pH of the solution is adjusted and maintained between 8 and 10 using a 1 M sodium carbonate solution. **p-Toluenesulfonyl chloride** is then added to the solution, and the reaction is carried out in a round-bottom flask with magnetic stirring. After the reaction is complete, the pH is adjusted to 2-3 with a 2 M HCl solution. The resulting precipitate is filtered, washed several times with distilled water, and recrystallized from methanol. The final product is washed with a 9:1 mixture of water and acetone and dried over anhydrous magnesium sulfate.[6]

Role in Drug Development: Signaling Pathway Inhibition

Sulfonamides are a critical class of compounds in drug development, exhibiting a wide range of biological activities.[8] Their therapeutic effects are often achieved by inhibiting specific enzymes involved in key signaling pathways.

Carbonic Anhydrase Inhibition

Many sulfonamide-based drugs act as potent inhibitors of carbonic anhydrases (CAs), a family of zinc-containing metalloenzymes. These enzymes catalyze the reversible hydration of carbon dioxide to bicarbonate and a proton. By binding to the zinc ion in the active site, sulfonamides block the enzyme's activity, which is crucial in various physiological processes, including pH regulation and fluid balance. This inhibitory action is the basis for the use of sulfonamide drugs as diuretics and treatments for glaucoma.[9]

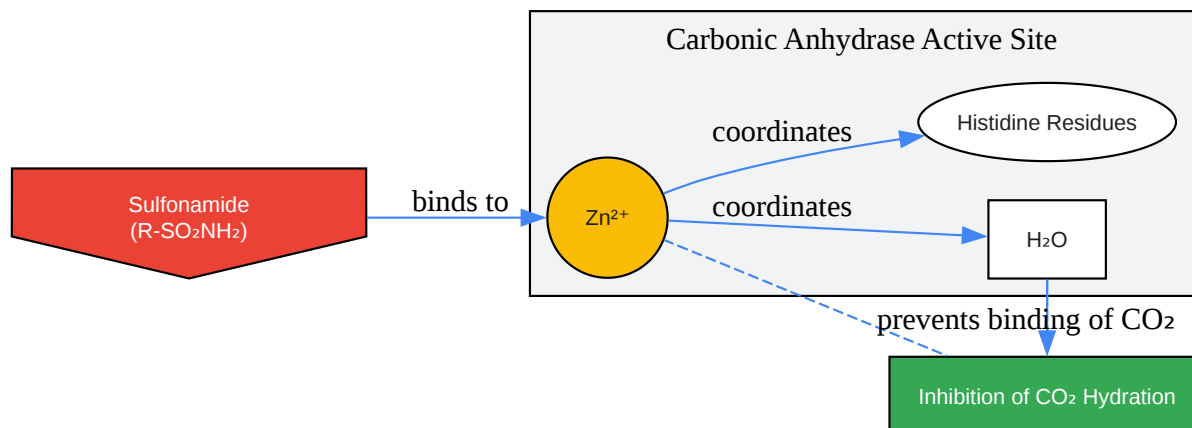

[Click to download full resolution via product page](#)

Caption: Inhibition of Carbonic Anhydrase by Sulfonamides.

JAK/STAT Signaling Pathway Inhibition

The Janus kinase/signal transducer and activator of transcription (JAK/STAT) pathway is a crucial signaling cascade that transmits information from extracellular cytokine signals to the nucleus, leading to the transcription of genes involved in immunity, cell proliferation, and differentiation. Dysregulation of this pathway is implicated in various inflammatory diseases and cancers. Certain sulfonamide-containing drugs have been developed as inhibitors of JAKs, blocking the phosphorylation cascade and subsequent gene transcription.

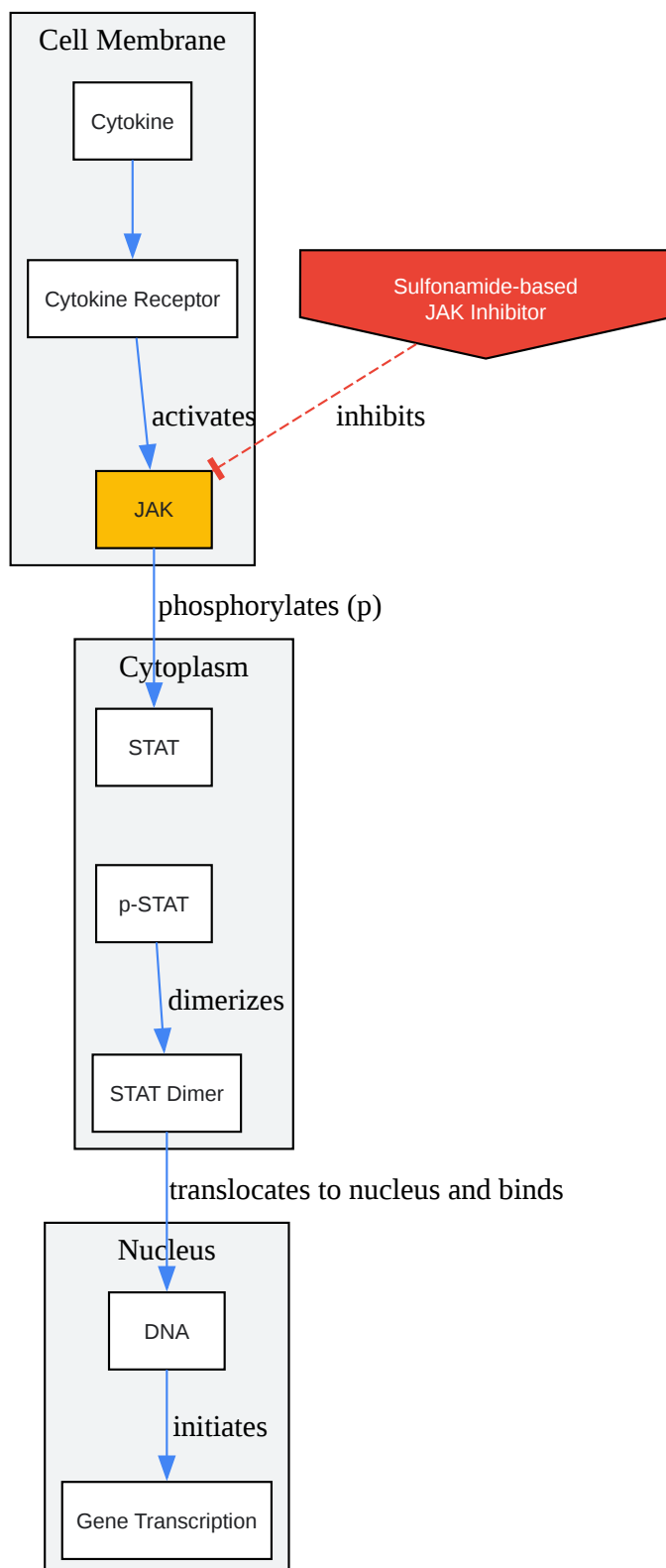

[Click to download full resolution via product page](#)

Caption: Inhibition of the JAK/STAT signaling pathway.

The Hinsberg Test: A Logical Application

The differential reactivity of primary, secondary, and tertiary amines with **p-toluenesulfonyl chloride** forms the basis of the Hinsberg test, a classical method for distinguishing between these amine classes. This logical relationship provides a practical application of the principles of sulfonamide synthesis.

- Primary amines react to form a sulfonamide that is soluble in aqueous alkali due to the acidic proton on the nitrogen.
- Secondary amines react to form a sulfonamide that is insoluble in aqueous alkali as it lacks an acidic proton.
- Tertiary amines do not react with **p-toluenesulfonyl chloride** under these conditions.

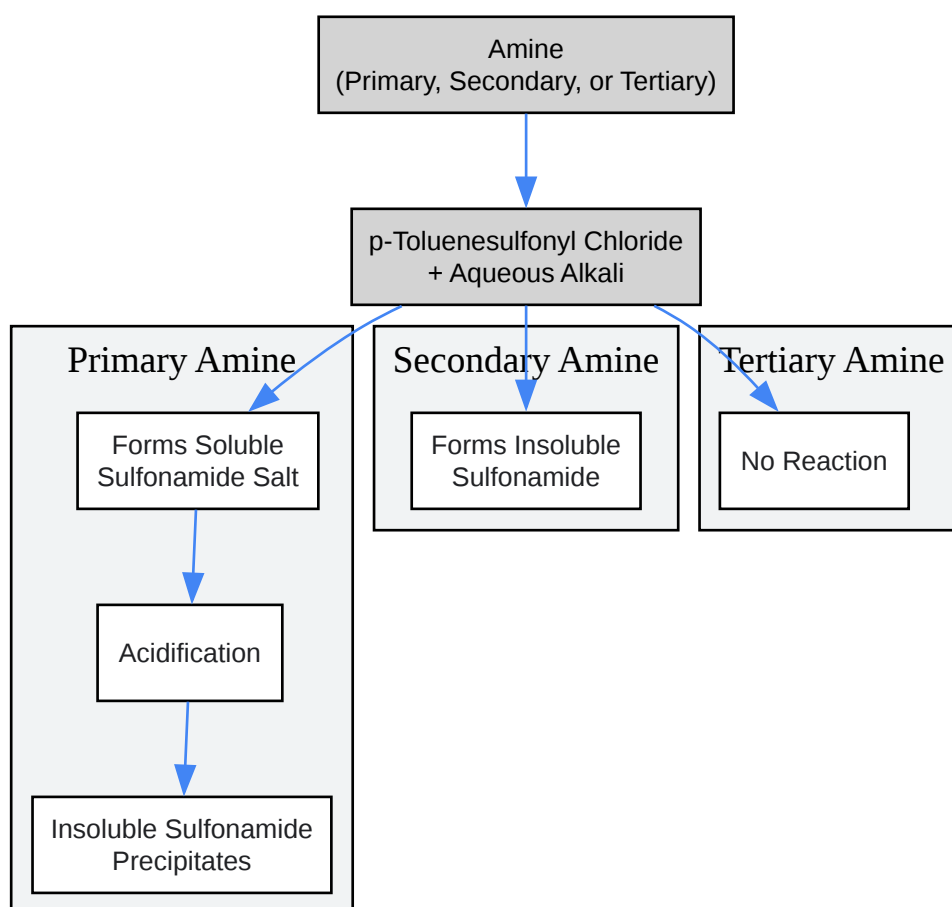

[Click to download full resolution via product page](#)

Caption: The Hinsberg test for distinguishing amines.

Need Custom Synthesis?

BenchChem offers custom synthesis for rare earth carbides and specific isotopic labeling.

Email: info@benchchem.com or [Request Quote Online](#).

References

- 1. cbijournal.com [cbijournal.com]
- 2. pdfs.semanticscholar.org [pdfs.semanticscholar.org]
- 3. Organic Syntheses Procedure [orgsyn.org]
- 4. An Expedient Synthesis of Sulfinamides from Sulfonyl Chlorides - PMC [pmc.ncbi.nlm.nih.gov]
- 5. prepchem.com [prepchem.com]
- 6. p-Toluenesulfonamides [organic-chemistry.org]
- 7. researchgate.net [researchgate.net]
- 8. JAK-STAT signaling pathway - Wikipedia [en.wikipedia.org]
- 9. The JAK/STAT signaling pathway: from bench to clinic - PMC [pmc.ncbi.nlm.nih.gov]
- To cite this document: BenchChem. [Preparation of Sulfonamides Using p-Toluenesulfonyl Chloride: A Technical Guide]. BenchChem, [2025]. [Online PDF]. Available at: [https://www.benchchem.com/product/b042831#preparation-of-sulfonamides-using-p-toluenesulfonyl-chloride]

Disclaimer & Data Validity:

The information provided in this document is for Research Use Only (RUO) and is strictly not intended for diagnostic or therapeutic procedures. While BenchChem strives to provide accurate protocols, we make no warranties, express or implied, regarding the fitness of this product for every specific experimental setup.

Technical Support: The protocols provided are for reference purposes. Unsure if this reagent suits your experiment? [[Contact our Ph.D. Support Team for a compatibility check](#)]

Need Industrial/Bulk Grade? [Request Custom Synthesis Quote](#)

BenchChem

Our mission is to be the trusted global source of essential and advanced chemicals, empowering scientists and researchers to drive progress in science and industry.

Contact

Address: 3281 E Guasti Rd
Ontario, CA 91761, United States
Phone: (601) 213-4426
Email: info@benchchem.com