

Spectroscopic Analysis of Ethyl Acetate: A Technical Guide

Author: BenchChem Technical Support Team. **Date:** December 2025

Compound of Interest

Compound Name: Ethyl acetate

Cat. No.: B041433

[Get Quote](#)

This guide provides a detailed overview of the nuclear magnetic resonance (NMR) and infrared (IR) spectroscopic data for pure **ethyl acetate**. It is intended for researchers, scientists, and professionals in drug development who utilize these analytical techniques for structural elucidation and quality control.

Spectroscopic Data Summary

The following tables summarize the key quantitative data from ^1H NMR, ^{13}C NMR, and IR spectroscopy for pure **ethyl acetate**.

Table 1: ^1H NMR Spectroscopic Data for **Ethyl Acetate**

Chemical Shift (δ) ppm	Multiplicity	Integration	Assignment
~1.25	Triplet (t)	3H	a: -O-CH ₂ -CH ₃
~2.04	Singlet (s)	3H	c: CH ₃ -C=O
~4.12	Quartet (q)	2H	b: -O-CH ₂ -CH ₃

Solvent: CDCl₃, Reference: TMS (δ 0.00 ppm)

Table 2: ^{13}C NMR Spectroscopic Data for **Ethyl Acetate**

Chemical Shift (δ) ppm	DEPT Information	Assignment
~14.2	CH ₃	CH ₃ -CH ₂ -O-
~21.0	CH ₃	CH ₃ -C=O
~60.4	CH ₂	-O-CH ₂ -CH ₃
~171.0	C (Quaternary)	-C=O

Solvent: CDCl₃, Reference: TMS (δ 0.00 ppm). Spectra are typically proton-decoupled.

Table 3: Infrared (IR) Spectroscopy Data for **Ethyl Acetate**

Wavenumber (cm ⁻¹)	Intensity	Vibrational Mode	Functional Group
~2975-2845	Medium-Strong	C-H Stretch	Alkyl (CH ₃ , CH ₂)
~1750-1735	Strong	C=O Stretch	Ester Carbonyl
~1250-1230	Strong	C-C-O Stretch (asymmetric)	Ester
~1047	Strong	O-C-C Stretch (symmetric)	Ester

Sample preparation: Liquid film.

Visualization of Molecular Structure and Spectroscopic Workflow

The following diagrams illustrate the chemical structure of **ethyl acetate** with assignments for NMR analysis and a typical workflow for spectroscopic experiments.

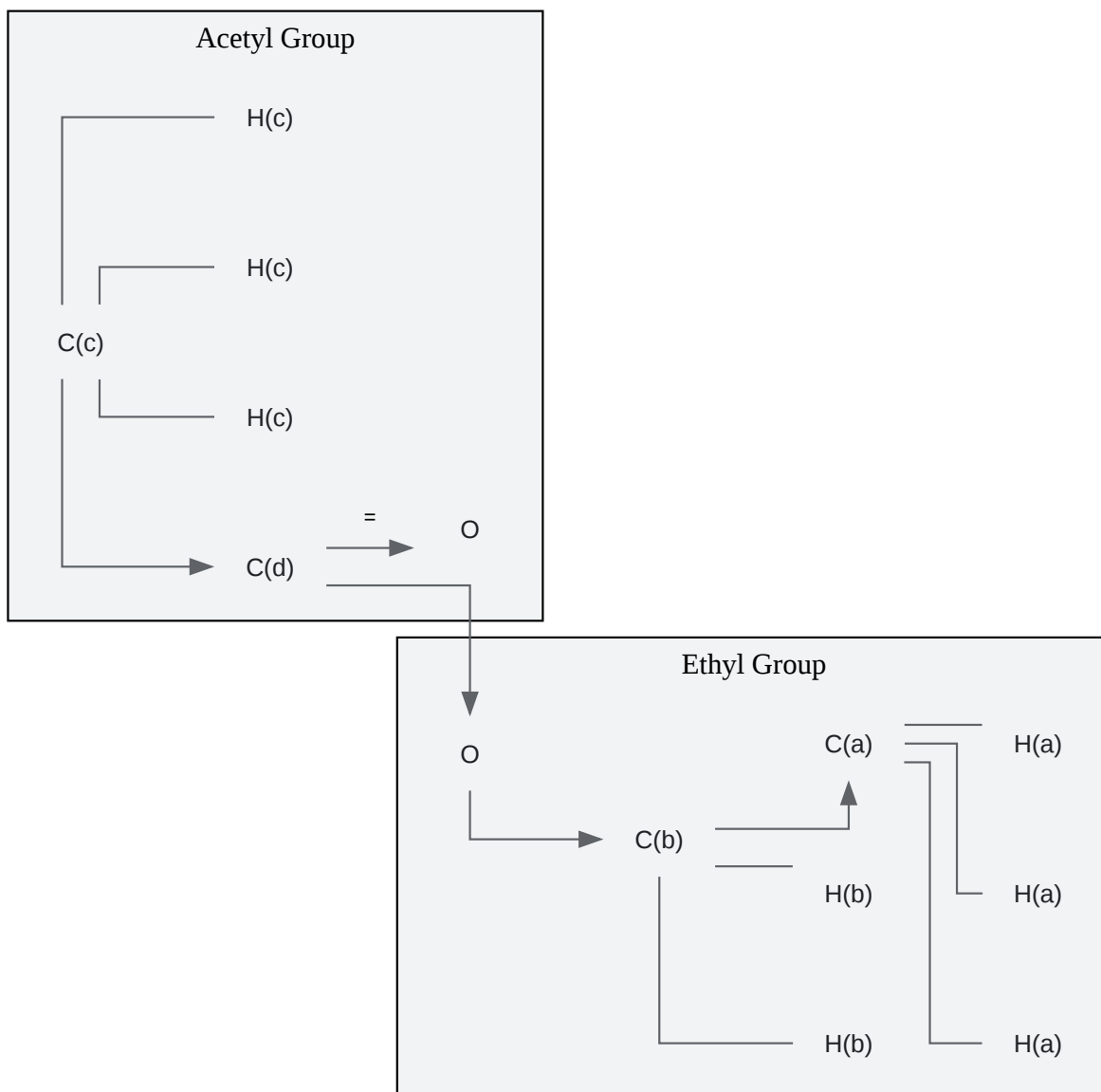

[Click to download full resolution via product page](#)

Caption: Molecular structure of **ethyl acetate** with NMR assignments.

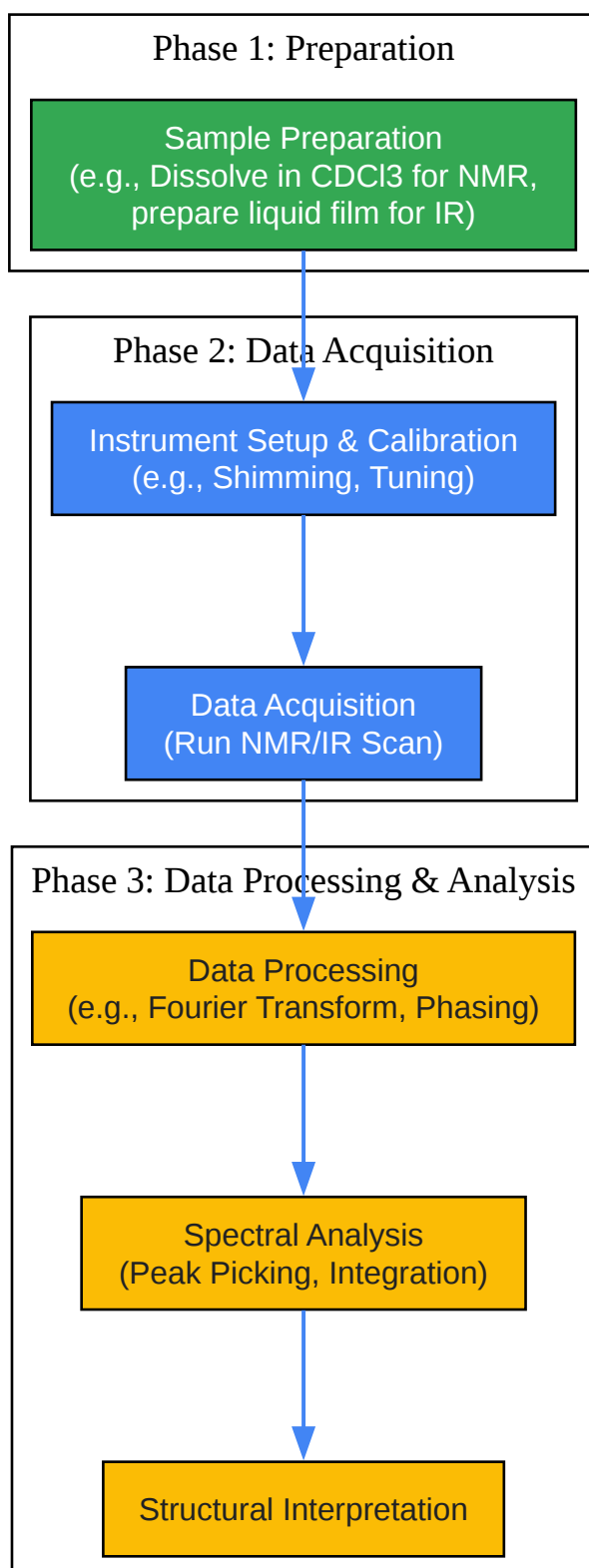

[Click to download full resolution via product page](#)

Caption: General workflow for spectroscopic analysis.

Experimental Protocols

Detailed methodologies for acquiring high-quality NMR and IR spectra of **ethyl acetate** are provided below.

- Sample Preparation:
 - Prepare a solution by dissolving approximately 5-20 mg of pure **ethyl acetate** in about 0.6-0.7 mL of deuterated chloroform (CDCl_3).
 - Add a small amount of tetramethylsilane (TMS) as an internal standard for chemical shift referencing (0.00 ppm).
 - Transfer the solution to a standard 5 mm NMR tube.
- Instrument Setup:
 - Place the NMR tube into the spectrometer's probe.
 - Lock the spectrometer onto the deuterium signal of the CDCl_3 solvent.
 - Shim the magnetic field to achieve a high level of homogeneity, which is crucial for obtaining sharp, well-resolved peaks.
- Data Acquisition (^1H NMR):
 - Acquire the ^1H NMR spectrum using a standard pulse sequence. A sufficient number of scans (e.g., 8 to 16) should be averaged to ensure a good signal-to-noise ratio.
- Data Acquisition (^{13}C NMR):
 - Acquire a proton-decoupled ^{13}C NMR spectrum. This technique removes C-H coupling, simplifying the spectrum so that each unique carbon atom appears as a single line.
 - Due to the low natural abundance of the ^{13}C isotope (~1.1%), a larger number of scans (e.g., 1024 or more) and a relaxation delay are typically required to obtain a spectrum with an adequate signal-to-noise ratio.

- Data Processing:
 - Apply a Fourier transform to the free induction decay (FID) to convert the time-domain data into a frequency-domain spectrum.
 - Phase-correct the spectrum to ensure all peaks are in the absorptive mode.
 - Calibrate the chemical shift axis by setting the TMS peak to 0.00 ppm.
 - For ^1H NMR, integrate the signals to determine the relative ratios of protons.
- Sample Preparation (Liquid Film Method):
 - Place a single drop of pure **ethyl acetate** onto the surface of one salt plate (e.g., NaCl or KBr).
- To cite this document: BenchChem. [Spectroscopic Analysis of Ethyl Acetate: A Technical Guide]. BenchChem, [2025]. [Online PDF]. Available at: [<https://www.benchchem.com/product/b041433#spectroscopic-data-nmr-ir-of-pure-ethyl-acetate>]

Disclaimer & Data Validity:

The information provided in this document is for Research Use Only (RUO) and is strictly not intended for diagnostic or therapeutic procedures. While BenchChem strives to provide accurate protocols, we make no warranties, express or implied, regarding the fitness of this product for every specific experimental setup.

Technical Support: The protocols provided are for reference purposes. Unsure if this reagent suits your experiment? [[Contact our Ph.D. Support Team for a compatibility check](#)]

Need Industrial/Bulk Grade? [Request Custom Synthesis Quote](#)

BenchChem

Our mission is to be the trusted global source of essential and advanced chemicals, empowering scientists and researchers to drive progress in science and industry.

Contact

Address: 3281 E Guasti Rd

Ontario, CA 91761, United States

Phone: (601) 213-4426

Email: info@benchchem.com