

# Quantitative comparison of skin permeation with and without 2-Octyldodecanol.

**Author:** BenchChem Technical Support Team. **Date:** December 2025

## Compound of Interest

Compound Name: 2-Octyldodecanol

Cat. No.: B041232

[Get Quote](#)

## The Impact of 2-Octyldodecanol on Skin Permeation: A Quantitative Comparison

For Researchers, Scientists, and Drug Development Professionals

The effective delivery of therapeutic agents through the skin is a significant challenge in the development of topical and transdermal formulations. The stratum corneum, the outermost layer of the skin, presents a formidable barrier to the permeation of most drug molecules. To overcome this, penetration enhancers are often incorporated into formulations to reversibly decrease the barrier function of the skin. Among these, the branched-chain saturated fatty alcohol, **2-Octyldodecanol**, has been investigated for its efficacy. This guide provides a detailed comparison of skin permeation with and without **2-Octyldodecanol**, supported by available experimental data and detailed methodologies.

## Quantitative Data Summary

While direct head-to-head quantitative permeation data is not abundant in publicly available literature, the following tables summarize the known effects of **2-Octyldodecanol** on the skin permeation of the bronchodilator formoterol fumarate and its impact on skin irritation, based on a key study in the field.

Table 1: Comparative Skin Permeation Enhancement of Formoterol Fumarate

Formulation	Drug Flux ( $\mu\text{g}/\text{cm}^2/\text{h}$ )	Enhancement Ratio*	Primary Irritation Index	Study
With 2-Octyldodecanol (1.0 mg/cm <sup>2</sup> )	Permeation was "remarkably enhanced"	-	1.38	Kakubari et al., 2006[1]
Without 2-Octyldodecanol (Control)	-	1	1.13	Kakubari et al., 2006[1]
With Hydrogenated Rosin Glycerol Ester	Significantly lower permeation than with 2-octyldodecanol	-	-	Kakubari et al., 2006[1]

\*Enhancement Ratio is calculated relative to the control formulation without the specific enhancer. A higher ratio indicates greater enhancement.

Note: The study by Kakubari et al. (2006) demonstrated a significant increase in the skin permeation of formoterol fumarate when **2-Octyldodecanol** was included in an ethylene-vinyl acetate (EVA) copolymer matrix patch compared to a formulation with hydrogenated rosin glycerol ester.[1] Although a specific drug flux value was not provided, the enhancement was described as "remarkable." [1]

Table 2: Skin Irritation Comparison

Formulation	Primary Irritation Index	Interpretation	Study
Control (patch without drug or enhancer)	0.21	Mild	Kakubari et al., 2006
Patch with 0.5 mg/cm <sup>2</sup> 2-Octyldodecanol	1.29	Mild	Kakubari et al., 2006
Patch with 1.0 mg/cm <sup>2</sup> 2-Octyldodecanol	1.38	Mild	Kakubari et al., 2006

The results suggest that while **2-Octyldodecanol** enhances permeation, it may also lead to a slight increase in skin irritation, although the observed irritation was still categorized as mild.

## Mechanism of Action: Disruption of Stratum Corneum Lipids

The primary mechanism by which **2-Octyldodecanol** enhances skin penetration is through the disruption of the highly organized lipid lamellae within the stratum corneum. This biophysical interaction increases the fluidity of the lipid bilayers, thereby reducing the diffusional resistance of the skin to drug molecules. Spectroscopic studies have confirmed that **2-Octyldodecanol** penetrates the stratum corneum and disorders the lipid chains. A signaling pathway in the classical sense is not implicated in this mechanism.

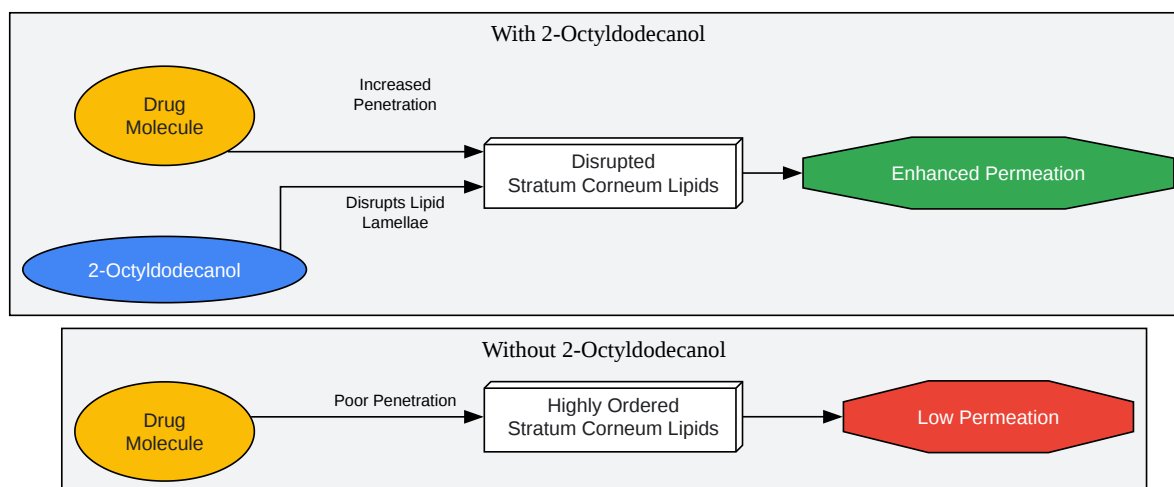

[Click to download full resolution via product page](#)

Caption: Mechanism of **2-Octyldodecanol** as a skin permeation enhancer.

## Experimental Protocols

The following is a detailed methodology for a typical in vitro skin permeation study to compare formulations with and without **2-Octyldodecanol**, utilizing Franz diffusion cells.

Objective: To quantify and compare the flux of a specific drug across a skin membrane from a formulation containing **2-Octyldodecanol** versus a control formulation without the enhancer.

Materials and Equipment:

- Franz Diffusion Cells: Vertical glass diffusion cells with a donor and receptor chamber.
- Skin Membrane: Excised human or animal (e.g., porcine) skin.
- Receptor Solution: A solution that maintains sink conditions, typically phosphate-buffered saline (PBS, pH 7.4) for hydrophilic drugs or a solution with a solubilizing agent for lipophilic drugs.
- Test Formulations:
  - Formulation A: Active drug in a vehicle without **2-Octyldodecanol** (Control).
  - Formulation B: Active drug in the same vehicle with a specified concentration of **2-Octyldodecanol**.
- Temperature Control System: A water bath or heating block to maintain the skin surface temperature at approximately 32°C.
- Magnetic Stirrers: For agitation of the receptor fluid.
- Analytical Instrumentation: High-Performance Liquid Chromatography (HPLC) or a similar sensitive and validated method for quantifying the drug in the receptor solution.

Procedure:

- Skin Preparation:
  - Thaw frozen skin at room temperature.
  - Carefully excise the subcutaneous fat and connective tissue.

- Cut the skin into sections large enough to be mounted on the Franz diffusion cells.
- Equilibrate the skin sections in the receptor solution for a defined period before mounting.
- Franz Diffusion Cell Assembly:
  - Mount the prepared skin membrane between the donor and receptor chambers of the Franz cell, ensuring the stratum corneum side faces the donor chamber.
  - Fill the receptor chamber with pre-warmed (32°C) and degassed receptor solution, ensuring no air bubbles are trapped beneath the skin.
  - Place the assembled cells in the heating block and allow them to equilibrate to 32°C.
- Formulation Application:
  - Apply a precise and consistent amount of the test formulation (either Formulation A or B) evenly onto the surface of the skin in the donor chamber.
- Sampling:
  - At predetermined time intervals (e.g., 0, 1, 2, 4, 6, 8, 12, and 24 hours), withdraw an aliquot of the receptor solution for analysis.
  - Immediately replace the withdrawn volume with an equal volume of fresh, pre-warmed receptor solution to maintain sink conditions.
- Sample Analysis:
  - Quantify the concentration of the drug in the collected samples using a validated HPLC method.
- Data Analysis:
  - Calculate the cumulative amount of drug permeated per unit area ( $\mu\text{g}/\text{cm}^2$ ) at each time point.
  - Plot the cumulative amount of drug permeated per unit area against time.

- Determine the steady-state flux ( $J_{ss}$ , in  $\mu\text{g}/\text{cm}^2/\text{h}$ ) from the slope of the linear portion of the plot.
- Calculate the permeability coefficient ( $K_p$ ) if the concentration of the drug in the donor vehicle is known.
- Calculate the Enhancement Ratio (ER) by dividing the flux of the formulation with **2-Octyldodecanol** (Formulation B) by the flux of the control formulation (Formulation A).

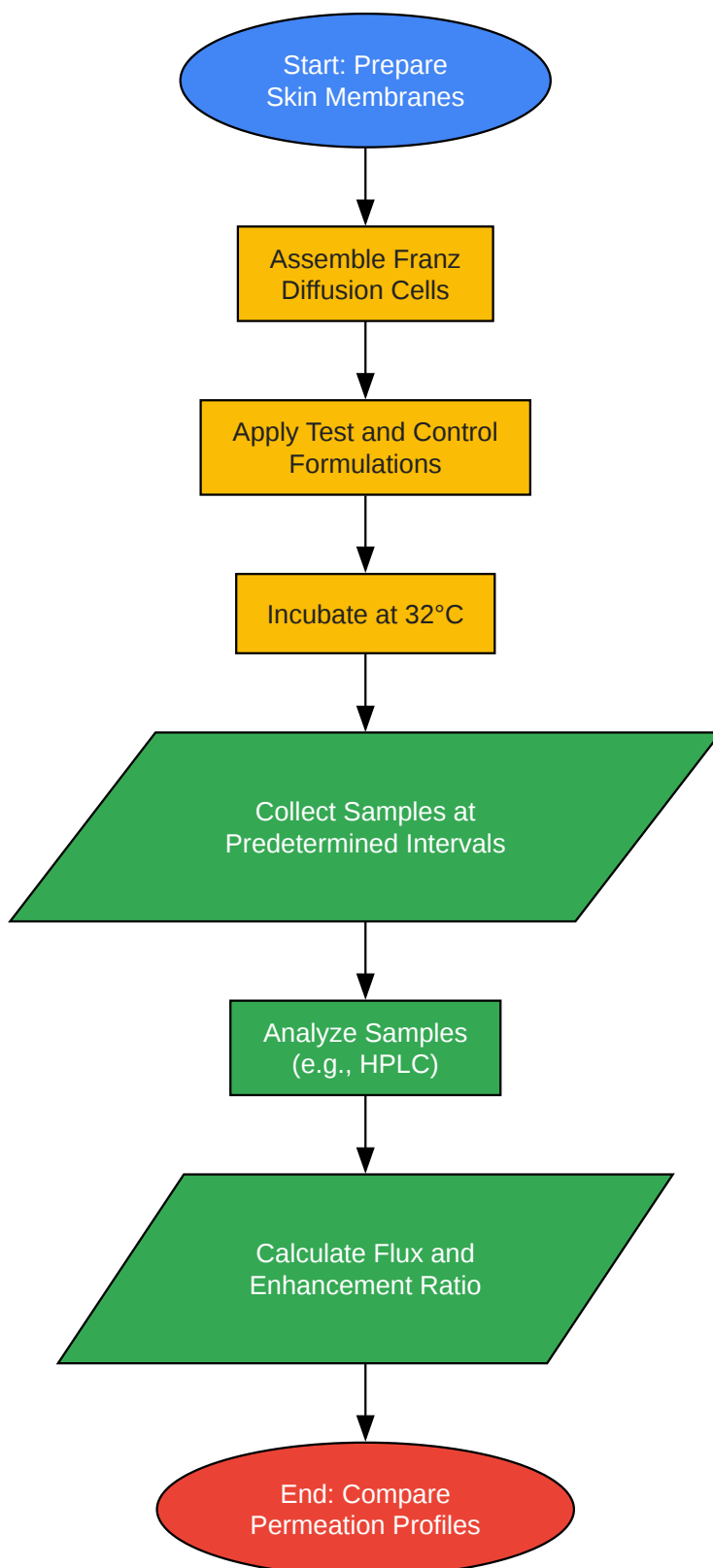

[Click to download full resolution via product page](#)

Caption: Experimental workflow for in vitro skin permeation study.

### Need Custom Synthesis?

BenchChem offers custom synthesis for rare earth carbides and specific isotopic labeling.

Email: [info@benchchem.com](mailto:info@benchchem.com) or [Request Quote Online](#).

## References

- 1. Effects of ethylcellulose and 2-octyldodecanol additives on skin permeation and irritation with ethylene-vinyl acetate copolymer matrix patches containing formoterol fumarate - PubMed [pubmed.ncbi.nlm.nih.gov]
- To cite this document: BenchChem. [Quantitative comparison of skin permeation with and without 2-Octyldodecanol.]. BenchChem, [2025]. [Online PDF]. Available at: [https://www.benchchem.com/product/b041232#quantitative-comparison-of-skin-permeation-with-and-without-2-octyldodecanol]

### Disclaimer & Data Validity:

The information provided in this document is for Research Use Only (RUO) and is strictly not intended for diagnostic or therapeutic procedures. While BenchChem strives to provide accurate protocols, we make no warranties, express or implied, regarding the fitness of this product for every specific experimental setup.

**Technical Support:** The protocols provided are for reference purposes. Unsure if this reagent suits your experiment? [[Contact our Ph.D. Support Team for a compatibility check](#)]

**Need Industrial/Bulk Grade?** [Request Custom Synthesis Quote](#)

## BenchChem

Our mission is to be the trusted global source of essential and advanced chemicals, empowering scientists and researchers to drive progress in science and industry.

### Contact

Address: 3281 E Guasti Rd

Ontario, CA 91761, United States

Phone: (601) 213-4426

Email: [info@benchchem.com](mailto:info@benchchem.com)