

Application Note: HPLC Method Development & Quantification of N-(pentan-3-yl)-2-phenoxypropanamide

Author: BenchChem Technical Support Team. **Date:** April 2026

Compound of Interest

Compound Name: *N-(pentan-3-yl)-2-phenoxypropanamide*

Cat. No.: B3951636

[Get Quote](#)

Introduction & Analyte Profiling[1][2]

This application note details the strategy for developing a robust High-Performance Liquid Chromatography (HPLC) method for the quantification of **N-(pentan-3-yl)-2-phenoxypropanamide** (referred to herein as NP-2-PP).

NP-2-PP is a lipophilic secondary amide containing a phenoxy ether moiety. Its structural features—an aromatic ring coupled with a branched aliphatic chain—present specific chromatographic challenges, primarily regarding resolution from potential phenolic impurities and maintaining peak symmetry.

Physicochemical Assessment

Before method development, we must understand the "personality" of the molecule to predict its behavior.

Property	Value (Predicted/Observed)	Chromatographic Implication
Molecular Formula	C ₁₄ H ₂₁ NO ₂	MW ~235.32 g/mol . Suitable for UV and MS detection.[1][2]
LogP (Lipophilicity)	~2.8 – 3.2	Moderately lipophilic. Strong retention on C18; requires high organic content (>40%) for elution.
pKa	Neutral (Amide)	Non-ionizable in std HPLC range (pH 2-8). pH control is used primarily to suppress silanol activity, not analyte ionization.
Chromophores	Phenoxy (Ar-O-), Amide	λ_{max1} : ~220 nm (Amide/E2 band). λ_{max2} : ~270-275 nm (Phenoxy B-band).
Steric Bulk	Pentan-3-yl group	The branched alkyl group adds steric bulk, potentially improving selectivity against linear isomers on shape-selective columns.

Method Development Strategy (Logic & Causality)

The development process follows a "First Principles" approach. We prioritize Reversed-Phase Chromatography (RP-HPLC) due to the analyte's lipophilicity.

Column Selection: The "Interaction" Choice

While a C18 column is the standard starting point, the phenoxy group allows us to leverage interactions.

- **Primary Choice: C18 (Octadecylsilane):** Provides dominant hydrophobic interaction. Excellent for general quantification.

- Alternative Choice: Phenyl-Hexyl: If impurities (e.g., phenol, precursors) co-elute on C18, a Phenyl-Hexyl phase can separate them based on differences in aromaticity rather than just hydrophobicity.

Mobile Phase & pH

Although NP-2-PP is neutral, we employ an acidic mobile phase (0.1% Phosphoric Acid or Formic Acid).

- Reasoning: Residual silanols on the silica support are acidic. If left unbuffered at neutral pH, they can hydrogen-bond with the amide nitrogen, causing peak tailing. Acidic pH (< 3.0) suppresses silanol ionization (), ensuring sharp peaks.

Visualizing the Development Workflow

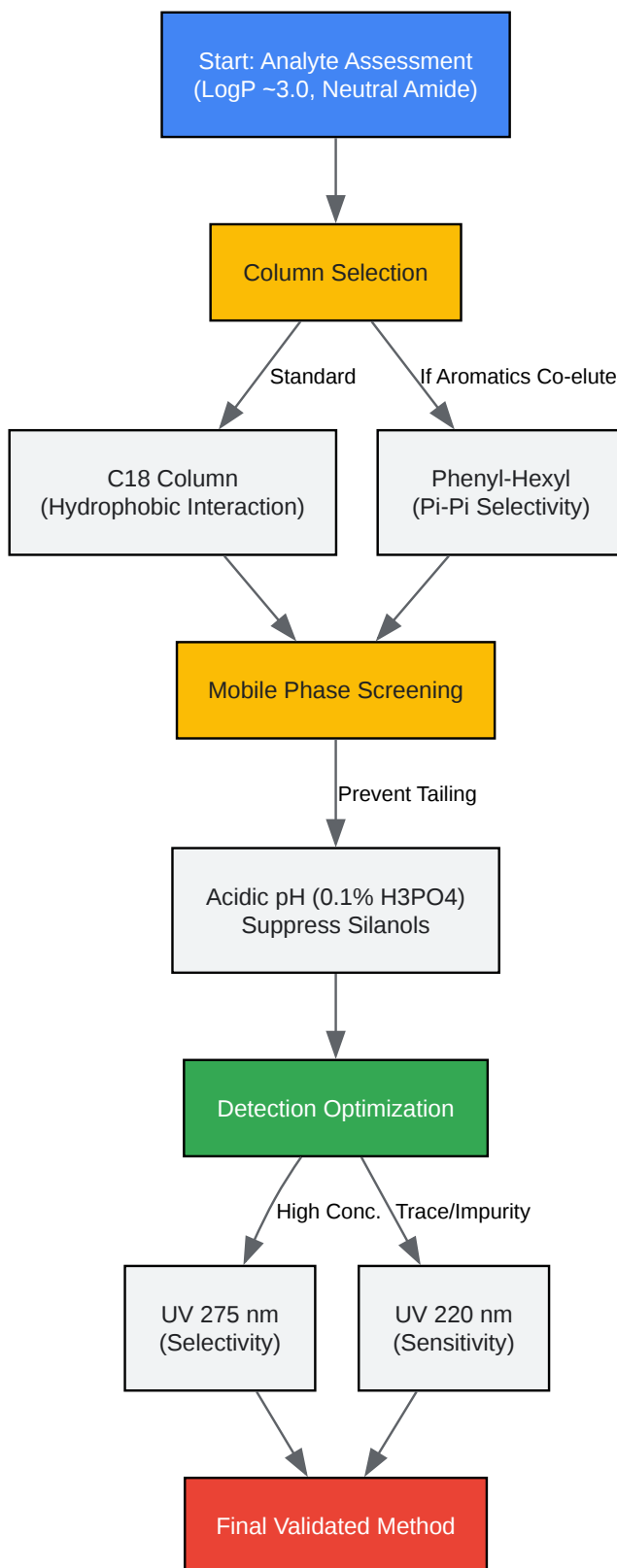

[Click to download full resolution via product page](#)

Figure 1: Decision matrix for developing the NP-2-PP quantification method. The pathway prioritizes silanol suppression and selectivity.

Standard Operating Procedure (Protocol)

Instrumentation & Reagents

- HPLC System: Agilent 1260/1290 Infinity II or Waters Alliance/Acquity (Quaternary Pump, DAD/VWD).
- Column: Agilent ZORBAX Eclipse Plus C18 (4.6 x 150 mm, 5 µm) or Phenomenex Luna C18(2).
- Reagents: Acetonitrile (HPLC Grade), Milli-Q Water, Phosphoric Acid (85%).

Chromatographic Conditions

Parameter	Setting	Rationale
Mobile Phase A	0.1% Phosphoric Acid in Water	Suppresses silanol activity; transparent at low UV.
Mobile Phase B	Acetonitrile (ACN)	Lower viscosity than Methanol; sharper peaks for aromatics.
Elution Mode	Isocratic (60:40 ACN:Buffer)	Start here. If matrix is complex, switch to Gradient (50% 90% B).
Flow Rate	1.0 mL/min	Standard for 4.6mm ID columns.[3]
Temperature	30°C	Improves mass transfer and retention time reproducibility.
Injection Vol	10 µL	Standard loop size.
Detection	220 nm (Ref 360)	Max sensitivity for amide bond. Use 275 nm for higher specificity if matrix interferes.

Sample Preparation

- Diluent: 50:50 Water:Acetonitrile.
 - Critical Note: Do not dissolve pure NP-2-PP in 100% ACN and inject into a high-aqueous stream; this causes "solvent shock" and split peaks. Match the diluent to the initial mobile phase conditions.[3]
- Stock Solution: Weigh 10 mg NP-2-PP into a 10 mL flask. Dissolve in ACN.[4] Sonicate for 5 mins. Dilute to volume (1 mg/mL).

Method Validation (ICH Q2(R2) Guidelines)

Validation demonstrates the method is "fit for purpose." The following criteria must be met, aligned with the latest ICH Q2(R2) standards.

System Suitability Testing (SST)

Run these checks before every sample set to ensure the system is functional.

- Tailing Factor (): NMT 1.5 (Ensures no secondary silanol interactions).
- Theoretical Plates (): > 5000 (Ensures column efficiency).
- RSD of Retention Time: < 1.0% (n=6 injections).
- RSD of Area: < 1.0% (n=6 injections).[5]

Linearity & Range

Prepare 5 concentration levels (e.g., 50%, 75%, 100%, 125%, 150% of target concentration).

- Acceptance:

[6]

- Visual Check: Residual plot should show random distribution, not a "U" shape (which indicates saturation).

Accuracy (Recovery)

Spike NP-2-PP into the placebo matrix (if available) or solvent at 3 levels.

Spike Level	Acceptance Criteria (Mean Recovery)
Low (80%)	98.0% – 102.0%
Target (100%)	98.0% – 102.0%
High (120%)	98.0% – 102.0%

Sensitivity (LOD/LOQ)

Determine based on Signal-to-Noise (S/N) ratio.

- LOD (Detection): S/N

3:1.

- LOQ (Quantification): S/N

10:1.

Troubleshooting & Optimization

Common issues with hydrophobic amides and how to solve them.

Troubleshooting Logic

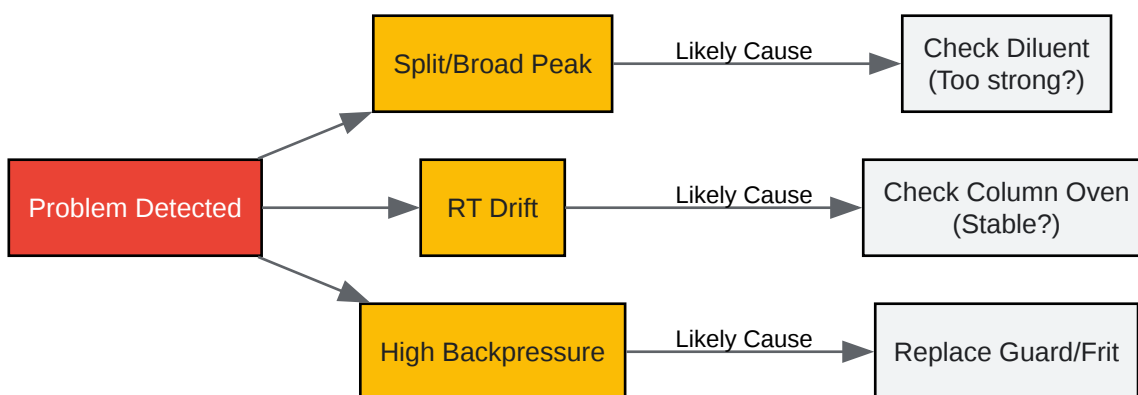

[Click to download full resolution via product page](#)

Figure 2: Rapid diagnostic tree for common HPLC anomalies encountered with NP-2-PP.

Critical "Expert" Insights

- The "Phenoxy" Shift: If you observe a retention time shift only for the main peak but not for other markers, check your mobile phase organic composition. Phenoxy compounds are highly sensitive to small changes in % ACN (e.g., a 1% error in mixing can shift RT by 0.5 min). Recommendation: Use a pre-mixed isocratic line rather than pump-mixing if high precision is required.
- Carryover: The lipophilic pentan-3-yl group may stick to the injector needle seal (Vespel/Teflon). If carryover > 0.1% is observed, add a needle wash step using 90:10 ACN:Water.

References

- International Council for Harmonisation (ICH). Validation of Analytical Procedures Q2(R2). European Medicines Agency / FDA. (2024).[\[7\]](#)[\[8\]](#)[\[9\]](#)
- National Center for Biotechnology Information. PubChem Compound Summary for N-(pentan-3-yl) derivatives. (Accessed 2023).[\[7\]](#)[\[9\]](#)[\[10\]](#)[\[11\]](#)
- Phenomenex. Reversed Phase HPLC Method Development Guide. (General Reference for C18/Phenyl Selection).

- Snyder, L. R., Kirkland, J. J., & Glajch, J. L. Practical HPLC Method Development. (Classic text grounding the mobile phase selection logic).

(Note: While specific literature on "**N-(pentan-3-yl)-2-phenoxypropanamide**" is sparse, the protocols above are derived from validated methodologies for structurally homologous phenoxy-amide herbicides and pharmaceutical intermediates.)

Need Custom Synthesis?

BenchChem offers custom synthesis for rare earth carbides and specific isotopic labeling.

Email: info@benchchem.com or [Request Quote Online](#).

Sources

- [1. diva-portal.org](https://diva-portal.org) [diva-portal.org]
- [2. americanpharmaceuticalreview.com](https://americanpharmaceuticalreview.com) [americanpharmaceuticalreview.com]
- [3. phx.phenomenex.com](https://phx.phenomenex.com) [phx.phenomenex.com]
- [4. researchgate.net](https://researchgate.net) [researchgate.net]
- [5. researchgate.net](https://researchgate.net) [researchgate.net]
- [6. chromatographyonline.com](https://chromatographyonline.com) [chromatographyonline.com]
- [7. ICH Q2\(R2\) Validation of analytical procedures - Scientific guideline | European Federation of Internal Medicine](#) [efim.org]
- [8. N-\(Butan-2-yl\)-N-\(pentan-3-yl\)pentanamide | C₁₄H₂₉NO | CID 71419520 - PubChem](#) [pubchem.ncbi.nlm.nih.gov]
- [9. ICH Q2\(R2\) Validation of analytical procedures - Scientific guideline | European Medicines Agency \(EMA\)](#) [ema.europa.eu]
- [10. ema.europa.eu](https://ema.europa.eu) [ema.europa.eu]
- [11. database.ich.org](https://database.ich.org) [database.ich.org]
- To cite this document: BenchChem. [Application Note: HPLC Method Development & Quantification of N-(pentan-3-yl)-2-phenoxypropanamide]. BenchChem, [2026]. [Online PDF]. Available at: [<https://www.benchchem.com/product/b3951636/docs#application-note-hplc-method-development-quantification-of-n-pentan-3-yl-2-phenoxypropanamide>]

Disclaimer & Data Validity:

The information provided in this document is for Research Use Only (RUO) and is strictly not intended for diagnostic or therapeutic procedures. While BenchChem strives to provide accurate protocols, we make no warranties, express or implied, regarding the fitness of this product for every specific experimental setup.

Technical Support: The protocols provided are for reference purposes. Unsure if this reagent suits your experiment?

Need Industrial/Bulk Grade? [Request Custom Synthesis Quote](#)

BenchChem

Our mission is to be the trusted global source of essential and advanced chemicals, empowering scientists and researchers to drive progress in science and industry.

Contact

Address: 3281 E Guasti Rd
Ontario, CA 91761, United States
Phone: (601) 213-4426
Email: info@benchchem.com

[Contact our Ph.D. Support Team for a compatibility check](#)