

# Computational Exploration of Triazolo[1,5-a]pyrazine Derivatives: A Technical Guide

**Author:** BenchChem Technical Support Team. **Date:** December 2025

## Compound of Interest

Compound Name: 4,5,6,7-Tetrahydro-1,2,3-triazolo[1,5-A]pyrazine

Cat. No.: B039368

[Get Quote](#)

For Researchers, Scientists, and Drug Development Professionals

## Introduction

The triazolo[1,5-a]pyrazine scaffold is a privileged heterocyclic system that has garnered significant attention in medicinal chemistry due to its diverse pharmacological activities. Derivatives of this core structure have shown promise as anticancer, antimicrobial, and antiparasitic agents. Computational studies have played a pivotal role in elucidating the mechanisms of action, identifying potential biological targets, and guiding the rational design of novel and more potent triazolo[1,5-a]pyrazine-based therapeutic agents. This technical guide provides an in-depth overview of the computational approaches used to study these derivatives, supported by experimental data and detailed protocols.

## Biological Activities and Molecular Targets

Triazolo[1,5-a]pyrazine derivatives have been investigated for a range of biological activities. The following table summarizes key findings from various studies, including the targeted disease, the specific molecular target (if identified), and the observed potency in terms of IC50 or Minimum Inhibitory Concentration (MIC) values.

Compound/Series	Therapeutic Area	Molecular Target(s)	Potency (IC50/MIC)	Reference
Series 4 Analogues	Antimalarial	Plasmodium falciparum	IC50: 0.3 to >20 $\mu\text{M}$	[1][2]
Derivatives 9b, 9c, 12b, 12c	Anticancer	TrkA, CDK2, VEGFR2, EGFR	GI50 (mean): 3.51-10.63 $\mu\text{M}$ ; IC50 (12b): 2.19-9.31 $\mu\text{M}$	[3]
Compound 16 (pyridine analog)	Antiparasitic	14 $\alpha$ -demethylase (Trypanosoma cruzi)	-	[4]
Compound 2e	Antibacterial	S. aureus, E. coli	MIC: 16-32 $\mu\text{g/mL}$	[5][6]
Compound 1	Anticancer	EGFR, Akt, Erk1/2	IC50: 7-11 $\mu\text{M}$	[7]
Compound 17l	Anticancer	c-Met, VEGFR-2	IC50 (kinases): 0.026-2.6 $\mu\text{M}$ ; IC50 (cells): 0.98-1.28 $\mu\text{M}$	[8][9]
Compounds 9f, 10c (triazine analog)	Anticancer	CDK2	IC50: 1.85-2.09 $\mu\text{M}$	[10]

## Signaling Pathways and Mechanisms of Action

Computational studies, in conjunction with experimental validation, have been instrumental in mapping the signaling pathways modulated by triazolo[1,5-a]pyrazine derivatives.

### Anticancer Activity: Inhibition of c-Met and VEGFR-2 Signaling

Several triazolo[1,5-a]pyrazine derivatives exhibit potent anticancer activity by dually inhibiting the c-Met and VEGFR-2 receptor tyrosine kinases.[8][9] These kinases are crucial regulators of

cell proliferation, survival, migration, and angiogenesis. The binding of these derivatives to the ATP-binding pocket of c-Met and VEGFR-2 disrupts their downstream signaling cascades, including the PI3K/Akt and MAPK/ERK pathways.

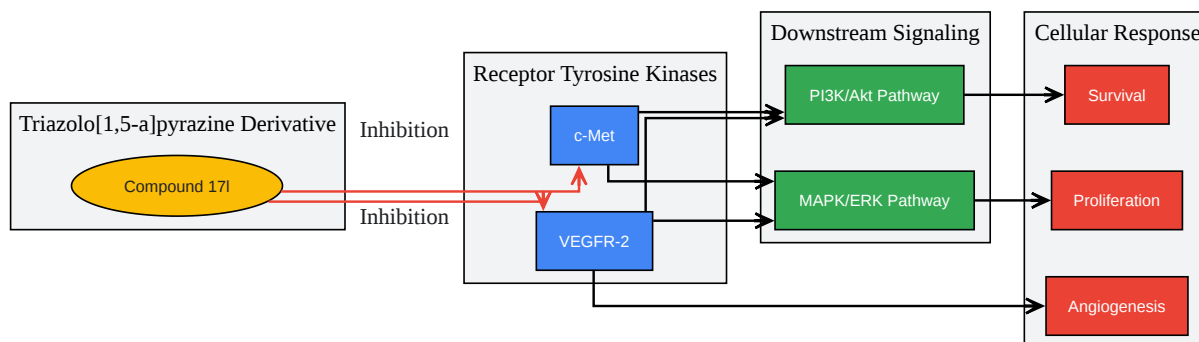

[Click to download full resolution via product page](#)

Inhibition of c-Met/VEGFR-2 signaling by triazolo[1,5-a]pyrazine derivatives.

## Antiparasitic Activity: Disruption of Sterol Biosynthesis in *Trypanosoma cruzi*

Certain triazolo[1,5-a]pyridine derivatives, which are structurally related to the pyrazine series, have shown trypanocidal activity by targeting the sterol biosynthesis pathway, specifically the enzyme 14 $\alpha$ -demethylase.[4] This enzyme is crucial for the synthesis of ergosterol, an essential component of the parasite's cell membrane. Inhibition of this enzyme leads to the accumulation of toxic sterol intermediates and disrupts membrane integrity.

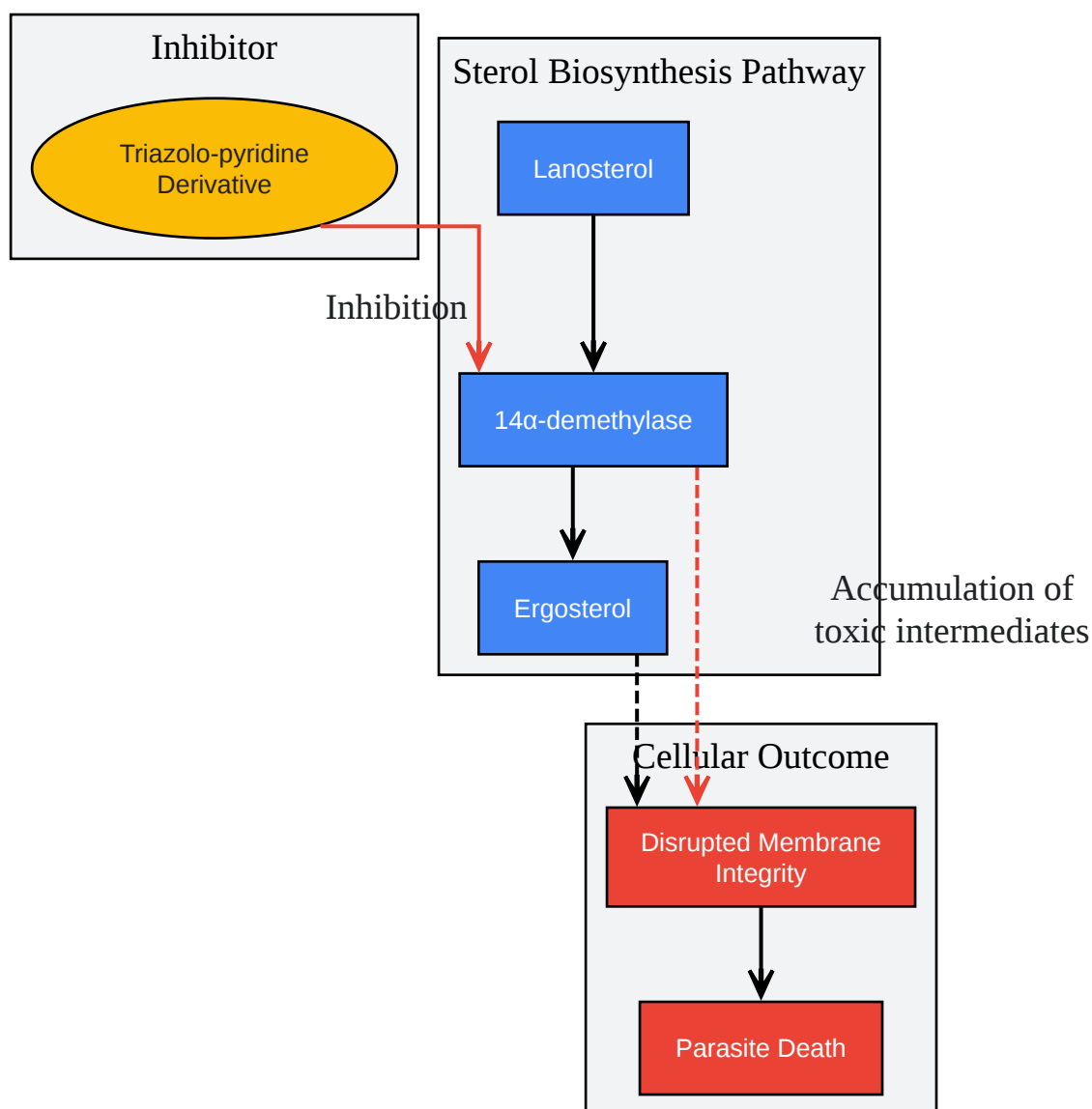

[Click to download full resolution via product page](#)

Disruption of the sterol biosynthesis pathway in *T. cruzi*.

## Computational and Experimental Protocols

### Molecular Docking

Molecular docking is a computational technique used to predict the binding orientation and affinity of a small molecule to a target protein.

Workflow for Molecular Docking:

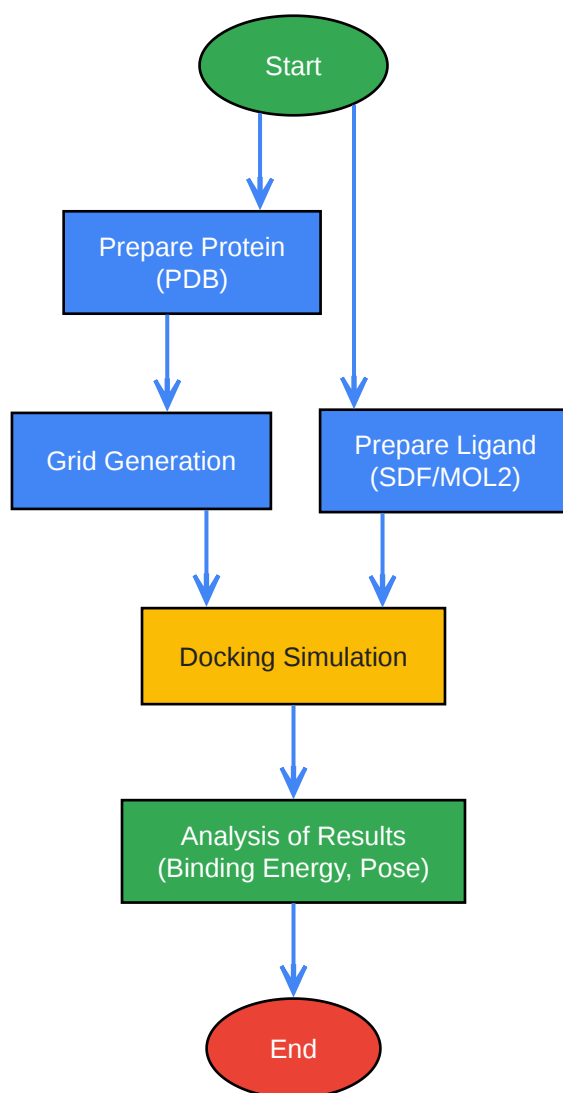

[Click to download full resolution via product page](#)

A generalized workflow for molecular docking studies.

Detailed Protocol (using AutoDock Vina):

- Protein Preparation:
  - Obtain the 3D structure of the target protein from the Protein Data Bank (PDB).
  - Remove water molecules and any co-crystallized ligands.
  - Add polar hydrogens and assign Kollman charges using AutoDock Tools (ADT).

- Save the prepared protein in PDBQT format.
- Ligand Preparation:
  - Draw the 2D structure of the triazolo[1,5-a]pyrazine derivative using a chemical drawing software (e.g., ChemDraw, MarvinSketch).
  - Convert the 2D structure to a 3D structure and perform energy minimization using a suitable force field (e.g., MMFF94).
  - Assign Gasteiger charges and define rotatable bonds using ADT.
  - Save the prepared ligand in PDBQT format.
- Grid Box Generation:
  - Define the binding site on the protein by specifying the center and dimensions of a grid box that encompasses the active site. This is typically centered on the co-crystallized ligand or predicted binding pocket.
- Docking Simulation:
  - Use AutoDock Vina to perform the docking calculation. A configuration file specifies the paths to the protein and ligand PDBQT files, the grid box parameters, and the exhaustiveness of the search.
- Analysis of Results:
  - Analyze the output file, which contains the binding affinities (in kcal/mol) and the coordinates of the predicted binding poses.
  - Visualize the protein-ligand interactions using software like PyMOL or Discovery Studio to identify key interactions such as hydrogen bonds and hydrophobic contacts.

## Experimental Validation

Anticancer Activity - MTT Assay:

The MTT (3-(4,5-dimethylthiazol-2-yl)-2,5-diphenyltetrazolium bromide) assay is a colorimetric assay for assessing cell metabolic activity.

- Cell Seeding: Seed cancer cells in a 96-well plate at a density of 5,000-10,000 cells/well and incubate for 24 hours.
- Compound Treatment: Treat the cells with various concentrations of the triazolo[1,5-a]pyrazine derivatives and incubate for 48-72 hours.
- MTT Addition: Add MTT solution to each well and incubate for 4 hours.
- Formazan Solubilization: Add a solubilizing agent (e.g., DMSO) to dissolve the formazan crystals.
- Absorbance Measurement: Measure the absorbance at 570 nm using a microplate reader.
- IC50 Calculation: Calculate the half-maximal inhibitory concentration (IC50) value from the dose-response curve.

#### Antibacterial Activity - Broth Microdilution:

This method is used to determine the Minimum Inhibitory Concentration (MIC) of an antimicrobial agent.

- Preparation of Inoculum: Prepare a standardized bacterial suspension (e.g., 0.5 McFarland standard).
- Serial Dilution: Perform a two-fold serial dilution of the triazolo[1,5-a]pyrazine derivative in a 96-well microtiter plate containing broth medium.
- Inoculation: Inoculate each well with the bacterial suspension.
- Incubation: Incubate the plate at 37°C for 18-24 hours.
- MIC Determination: The MIC is the lowest concentration of the compound that completely inhibits visible bacterial growth.

## Conclusion

Computational studies are an indispensable tool in the modern drug discovery and development pipeline for triazolo[1,5-a]pyrazine derivatives. Molecular docking and other in silico methods provide valuable insights into the molecular interactions and mechanisms of action, enabling the rational design of more effective and selective therapeutic agents. The integration of computational predictions with experimental validation is crucial for accelerating the discovery of novel drug candidates based on this versatile scaffold. This guide provides a foundational understanding of the key computational and experimental methodologies employed in this exciting area of research.

### *Need Custom Synthesis?*

*BenchChem offers custom synthesis for rare earth carbides and specific isotopic labeling.*

*Email: [info@benchchem.com](mailto:info@benchchem.com) or [Request Quote Online](#).*

## References

- 1. GROMACS: MD Simulation of a Protein-Ligand Complex [[angeloraymondrossi.github.io](https://angeloraymondrossi.github.io)]
- 2. protocols.io [[protocols.io](https://protocols.io)]
- 3. youtube.com [[youtube.com](https://youtube.com)]
- 4. GROMACS Tutorials [[mdtutorials.com](https://mdtutorials.com)]
- 5. bioinformaticsreview.com [[bioinformaticsreview.com](https://bioinformaticsreview.com)]
- 6. classcentral.com [[classcentral.com](https://classcentral.com)]
- 7. Molecular Dynamics Simulations of Protein–Drug Complexes: A Computational Protocol for Investigating the Interactions of Small-Molecule Therapeutics with Biological Targets and Biosensors | Springer Nature Experiments [[experiments.springernature.com](https://experiments.springernature.com)]
- 8. Cytotoxicity MTT Assay Protocols and Methods | Springer Nature Experiments [[experiments.springernature.com](https://experiments.springernature.com)]
- 9. Protein-Ligand Complex [[mdtutorials.com](https://mdtutorials.com)]
- 10. Molecular Dynamics Simulations of Protein–Drug Complexes: A Computational Protocol for Investigating the Interactions of Small-Molecule Therapeutics with Biological Targets and Biosensors | Biophysical chemistry laboratory [[biophysics.chem.udel.edu](https://biophysics.chem.udel.edu)]



- To cite this document: BenchChem. [Computational Exploration of Triazolo[1,5-a]pyrazine Derivatives: A Technical Guide]. BenchChem, [2025]. [Online PDF]. Available at: [<https://www.benchchem.com/product/b039368#computational-studies-of-triazolo-1-5-a-pyrazine-derivatives>]

---

### Disclaimer & Data Validity:

The information provided in this document is for Research Use Only (RUO) and is strictly not intended for diagnostic or therapeutic procedures. While BenchChem strives to provide accurate protocols, we make no warranties, express or implied, regarding the fitness of this product for every specific experimental setup.

**Technical Support:** The protocols provided are for reference purposes. Unsure if this reagent suits your experiment? [[Contact our Ph.D. Support Team for a compatibility check](#)]

**Need Industrial/Bulk Grade?** [Request Custom Synthesis Quote](#)

## BenchChem

Our mission is to be the trusted global source of essential and advanced chemicals, empowering scientists and researchers to drive progress in science and industry.

### Contact

Address: 3281 E Guasti Rd

Ontario, CA 91761, United States

Phone: (601) 213-4426

Email: [info@benchchem.com](mailto:info@benchchem.com)