

Application Notes and Protocols for NMR Spectroscopy of α,α -Disubstituted Amino Acids

Author: BenchChem Technical Support Team. **Date:** May 2026

Compound of Interest

Compound Name: 2-Amino-2-ethylhexanoic acid

CAS No.: 114781-15-6

Cat. No.: B039256

[Get Quote](#)

Abstract

α,α -Disubstituted amino acids (α,α -AAs) represent a unique class of non-proteinogenic amino acids integral to the development of novel therapeutics and advanced biomaterials. Their defining structural feature—the replacement of the α -hydrogen with a second substituent—imposes significant conformational constraints, leading to peptides and proteins with enhanced stability and predictable secondary structures.[1][2] This guide provides a comprehensive overview of Nuclear Magnetic Resonance (NMR) spectroscopy techniques tailored for the detailed structural and conformational analysis of α,α -disubstituted amino acids and their peptide derivatives. We delve into the causality behind experimental choices, from sample preparation to the selection of advanced 2D NMR experiments, offering researchers, scientists, and drug development professionals a robust framework for leveraging NMR in their work.

Introduction: The Unique Structural Landscape of α,α -Disubstituted Amino Acids

The substitution at the α -carbon fundamentally alters the stereochemistry and conformational freedom of the amino acid backbone. Unlike their proteinogenic counterparts, α,α -disubstituted

amino acids lack an α -proton, a key feature often exploited in standard NMR analyses of peptides. This absence necessitates a modified approach to structure elucidation and conformational analysis. The steric hindrance introduced by the two α -substituents restricts the accessible Ramachandran space, often forcing peptides to adopt specific secondary structures like 310-helices or fully extended C5-conformations.[1][2] This property is invaluable in drug design, where stabilizing a particular conformation can enhance binding affinity and biological activity.[3][4][5]

Understanding the three-dimensional structure of these molecules is paramount for harnessing their full potential. NMR spectroscopy stands out as a powerful, non-destructive technique for elucidating detailed atomic-level information about molecular structure, conformation, and dynamics in solution, closely mimicking physiological conditions.[6]

Foundational NMR Concepts for α,α -Disubstituted Amino Acids

The absence of the α -proton in α,α -disubstituted amino acids means that traditional through-bond correlation experiments that rely on 1H-1H J-couplings to the α -proton for sequential assignment are not directly applicable. Therefore, our strategy will heavily leverage through-bond correlations to and from the α -carbon and through-space correlations.

Key Nuclei for Observation

- **^1H NMR:** While lacking the α -proton, ^1H NMR remains crucial for observing the protons on the side-chain substituents, the amide protons (in $\text{H}_2\text{O}/\text{D}_2\text{O}$ mixtures), and any N- or C-terminal protecting groups.
- **^{13}C NMR:** The quaternary α -carbon is a key spectroscopic marker. Its chemical shift is sensitive to the nature of the substituents and the local conformation. Additionally, the carbonyl carbon and the side-chain carbons provide invaluable structural information.[7][8]
- **^{15}N NMR:** For isotopically labeled samples, ^{15}N NMR provides direct insight into the electronic environment of the backbone amide nitrogen.

Experimental Protocols

A successful NMR study begins with meticulous sample preparation. The quality of the data is directly proportional to the quality of the sample.

Protocol: Sample Preparation for NMR Analysis

- **Material Purity:** Ensure the α,α -disubstituted amino acid or peptide is of high purity (>95%), as impurities can complicate spectral analysis.[9]
- **Solvent Selection:** Choose a deuterated solvent that fully dissolves the sample.[10] For peptides, a mixture of 90% H₂O/10% D₂O is often used to observe exchangeable amide protons, which are crucial for structural studies.[9] For organic-soluble derivatives, CDCl₃, DMSO-d₆, or CD₃OD are common choices.
- **Concentration:**
 - For ¹H NMR, a concentration of 5-25 mg in 0.6-0.7 mL of solvent is generally sufficient.
 - For peptides undergoing detailed 2D NMR analysis, concentrations of 1-5 mM are recommended to achieve a good signal-to-noise ratio in a reasonable time.[9][11]
 - For ¹³C NMR, higher concentrations are often necessary due to the lower natural abundance and gyromagnetic ratio of ¹³C. Aim for a saturated solution if material permits.
- **Filtration:** To ensure magnetic field homogeneity and prevent line broadening, filter the sample through a glass wool plug in a Pasteur pipette into a clean, high-quality NMR tube. [10] This removes any particulate matter.
- **Internal Standard:** For accurate chemical shift referencing, add an appropriate internal standard. Tetramethylsilane (TMS) is common for organic solvents, while 4,4-dimethyl-4-silapentane-1-sulfonic acid (DSS) or 2,2-dimethyl-2-silapentane-5-sulfonate (TSP) are used for aqueous samples.[10]
- **Degassing (Optional):** For samples sensitive to oxidation or for quantitative NOE studies, degassing the sample by several freeze-pump-thaw cycles can remove dissolved oxygen, which is paramagnetic and can affect relaxation times.

NMR Experiments for Structural Elucidation

The following is a recommended suite of experiments for the comprehensive analysis of an α,α -disubstituted amino acid-containing peptide.

1D NMR Experiments

- ^1H NMR: The initial and quickest experiment to assess sample purity and get an overview of the proton environment.
- ^{13}C NMR: Provides a count of the number of unique carbon atoms and information about their chemical environment. The chemical shift of the quaternary α -carbon is particularly diagnostic.[8]

2D NMR Experiments: A Step-by-Step Workflow

The lack of an α -proton requires a greater reliance on heteronuclear correlation experiments.

Workflow for NMR Analysis of α,α -Disubstituted Peptides

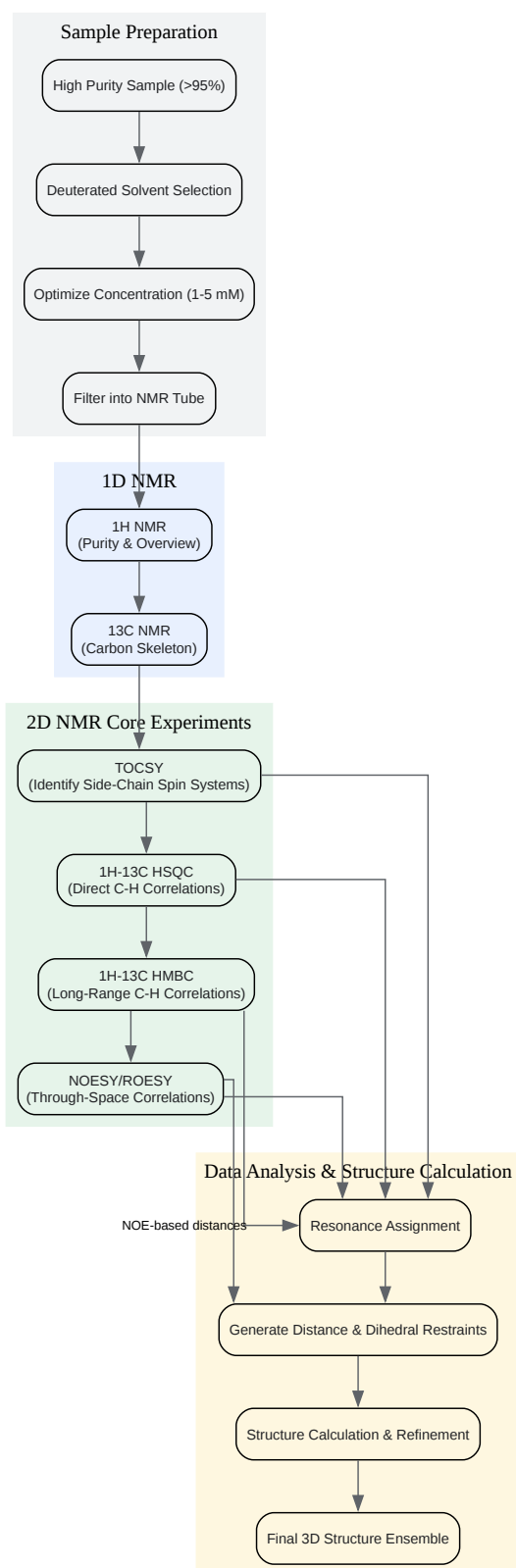

[Click to download full resolution via product page](#)

Caption: Experimental workflow for NMR analysis of α,α -disubstituted peptides.

The TOCSY experiment is invaluable for identifying the spin systems of the amino acid side chains.[\[6\]](#)[\[9\]](#)[\[12\]](#)

- Objective: To correlate all protons within a coupled spin system. For example, in a leucine residue, the H β , H γ , and H δ protons will all show correlations to each other.
- Key Parameters:
 - Mixing Time: A longer mixing time (e.g., 80 ms) allows for magnetization transfer throughout the entire spin system.[\[9\]](#)
- Interpretation: Each vertical "strip" of cross-peaks corresponds to a single amino acid's side-chain spin system. This allows for the classification of amino acid types (e.g., distinguishing a valine from a leucine).[\[12\]](#)

The HSQC experiment provides direct one-bond correlations between protons and their attached carbons.[\[13\]](#)

- Objective: To map each proton to its directly bonded carbon.
- Interpretation: This is a powerful editing tool. It helps to resolve overlap in the ^1H spectrum by spreading peaks out over the wider ^{13}C chemical shift range. It confirms the assignments made from TOCSY by correlating the side-chain protons to their corresponding carbons.

The HMBC experiment is the cornerstone for linking different spin systems and for sequential assignment in the absence of an α -proton.

- Objective: To observe correlations between protons and carbons that are two or three bonds away.
- Crucial Correlations for α,α -AAs:
 - Side-chain H to α -C and C=O: Protons on the β -carbon of a side chain will show a correlation to the quaternary α -carbon and the carbonyl carbon of the same residue.
 - Amide H to α -C and C=O: The amide proton (HN) of residue i will show correlations to the α -carbon and carbonyl carbon of its own residue (i), and crucially, to the carbonyl carbon

of the preceding residue (i-1). This is key for sequential walking.

- Side-chain H to neighboring C=O: Protons on the β -carbon of residue i may show a correlation to the carbonyl carbon of residue i-1.

Logical Flow for Sequential Assignment using HMBC

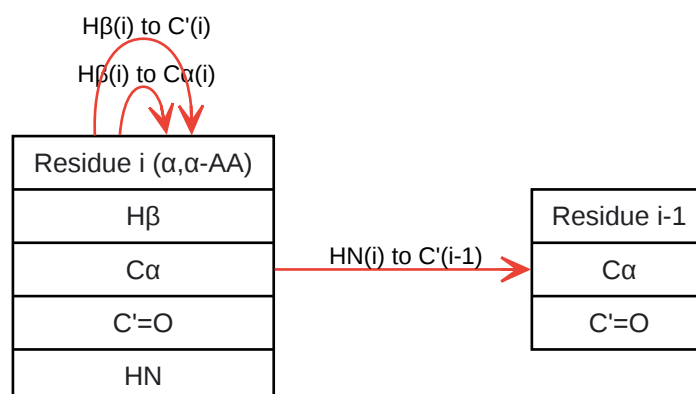

[Click to download full resolution via product page](#)

Need Custom Synthesis?

BenchChem offers custom synthesis for rare earth carbides and specific isotopic labeling.

Email: info@benchchem.com or [Request Quote Online](#).

Sources

1. Design and synthesis of chiral alpha, alpha-disubstituted amino acids and conformational study of their oligopeptides - PubMed [pubmed.ncbi.nlm.nih.gov]
2. [researchgate.net](https://www.researchgate.net) [[researchgate.net](https://www.researchgate.net)]
3. api.pageplace.de [api.pageplace.de]
4. Applications of Solution NMR in Drug Discovery - PMC [[pmc.ncbi.nlm.nih.gov](https://pubmed.ncbi.nlm.nih.gov/pmc)]
5. [spectroscopyonline.com](https://www.spectroscopyonline.com) [[spectroscopyonline.com](https://www.spectroscopyonline.com)]
6. [pharmacy.nmims.edu](https://www.pharmacy.nmims.edu) [[pharmacy.nmims.edu](https://www.pharmacy.nmims.edu)]
7. A high-resolution solid-state ^{13}C -NMR study on [1- ^{13}C]Ala and [3- ^{13}C]Ala and [1- ^{13}C]Leu and Val-labelled bacteriorhodopsin. Conformation and dynamics of transmembrane

helices, loops and termini, and hydration-induced conformational change - PubMed
[pubmed.ncbi.nlm.nih.gov]

- 8. [13C NMR analysis of peptides and amino acids | Steelyard Analytics, Inc.](#)
[steelyardanalytics.com]
- 9. [chem.uzh.ch](#) [chem.uzh.ch]
- 10. [NMR Sample Preparation | Chemical Instrumentation Facility](#) [cif.iastate.edu]
- 11. [nmr-bio.com](#) [nmr-bio.com]
- 12. [hoffman.cm.utexas.edu](#) [hoffman.cm.utexas.edu]
- 13. [chem.libretexts.org](#) [chem.libretexts.org]
- To cite this document: BenchChem. [Application Notes and Protocols for NMR Spectroscopy of α,α -Disubstituted Amino Acids]. BenchChem, [2026]. [Online PDF]. Available at: [https://www.benchchem.com/product/b039256/docs#application-notes-and-protocols-for-nmr-spectroscopy-of-disubstituted-amino-acids]

Disclaimer & Data Validity:

The information provided in this document is for Research Use Only (RUO) and is strictly not intended for diagnostic or therapeutic procedures. While BenchChem strives to provide accurate protocols, we make no warranties, express or implied, regarding the fitness of this product for every specific experimental setup.

Technical Support: The protocols provided are for reference purposes. Unsure if this reagent suits your experiment?

Need Industrial/Bulk Grade? [Request Custom Synthesis Quote](#)

BenchChem

Our mission is to be the trusted global source of essential and advanced chemicals, empowering scientists and researchers to drive progress in science and industry.

Contact

Address: 3281 E Guasti Rd
Ontario, CA 91761, United States
Phone: (601) 213-4426
Email: info@benchchem.com

Contact our Ph.D. Support Team for a compatibility check