

# mass spectrometry fragmentation pattern of C<sub>16</sub>H<sub>16</sub>O<sub>2</sub> esters

**Author:** BenchChem Technical Support Team. **Date:** April 2026

## Compound of Interest

Compound Name: *p*-Toluic acid, 3,5-dimethylphenyl  
ester

CAS No.: 62261-93-2

Cat. No.: B3873386

[Get Quote](#)

Technical Comparison Guide: Mass Spectrometry Fragmentation of C<sub>16</sub>H<sub>16</sub>O<sub>2</sub> Ester Isomers

## Introduction: The Isomer Challenge

In metabolomics and synthetic quality control, distinguishing structural isomers with the formula C<sub>16</sub>H<sub>16</sub>O<sub>2</sub> (Molecular Weight: 238.28 Da) is a critical analytical challenge. With a Degree of Unsaturation (DoU) of 9, these molecules possess high aromatic stability, often yielding resistant molecular ions ( ).

While Nuclear Magnetic Resonance (NMR) is definitive for structure, it requires milligram-scale purity. Gas Chromatography-Mass Spectrometry (GC-MS) remains the workhorse for high-throughput screening. However, without a deep understanding of fragmentation mechanics, isomers like Benzyl Cinnamate and Phenethyl Benzoate can be easily misidentified due to their identical retention indices on non-polar columns and similar aromatic content.

This guide provides a definitive, mechanism-based comparison of these two primary isomers, establishing a self-validating identification protocol.

## Comparative Analysis: Structural Fingerprinting

The differentiation relies on identifying the location of the carbonyl group relative to the aromatic rings. We compare the two most prevalent isomers:

- Benzyl Cinnamate: Cinnamic acid derivative (

)

- Phenethyl Benzoate: Benzoic acid derivative (

)

### Table 1: Diagnostic Ion Comparison (EI, 70 eV)

Feature	Benzyl Cinnamate	Phenethyl Benzoate	Mechanistic Origin
Molecular Ion ( )	m/z 238 (Weak/Moderate)	m/z 238 (Weak)	Parent stability is similar; differentiation requires fragments.
Base Peak (100%)	m/z 131	m/z 105	-Cleavage: Acylium ion formation dictates the base peak.
Secondary Diagnostic	m/z 103	m/z 104	Stability: Styryl cation (103) vs. Styrene radical cation (104).
Tertiary Diagnostic	m/z 91 (Strong)	m/z 77 (Strong)	Tropylium vs. Phenyl: Benzyl group (Cinnamate) vs. Phenyl group (Benzoate).
Rearrangement	Minimal	McLafferty-Type	Phenethyl benzoate undergoes H-transfer to form Styrene ( ).

## Mechanistic Deep Dive

To ensure scientific integrity, we must validate why these fragments occur. This prevents "fingerprint matching" errors when novel derivatives are encountered.

### A. Benzyl Cinnamate: Resonance Stabilization

The fragmentation is driven by the stability of the Cinnamoyl cation (m/z 131). Upon electron impact, the bond between the carbonyl carbon and the ether oxygen breaks (

-cleavage).

- Pathway:

- The resulting  $m/z$  131 ion is highly stable due to resonance across the double bond and phenyl ring.
- Secondary Loss: The cinnamoyl cation loses CO (neutral, 28 Da) to form the Styryl cation ( $m/z$  103).

## B. Phenethyl Benzoate: The McLafferty Rearrangement

This molecule exhibits a classic Benzoyl cation ( $m/z$  105) via

-cleavage. However, the definitive differentiator is the  $m/z$  104 peak.

- Mechanism: A McLafferty-type rearrangement occurs involving a 6-membered transition state.<sup>[1]</sup> The hydrogen on the  $\gamma$ -carbon of the alkoxy chain (relative to the ether oxygen) transfers to the carbonyl oxygen.
- Outcome: This cleavage releases neutral Benzoic Acid (122 Da) and generates the Styrene radical cation ( $m/z$  104).
- Note: While  $m/z$  105 is usually the base peak, the presence of  $m/z$  104 is the "smoking gun" for phenethyl esters.

## Visualization of Fragmentation Pathways

The following diagrams illustrate the competitive pathways.

### Diagram 1: Fragmentation Logic Flow

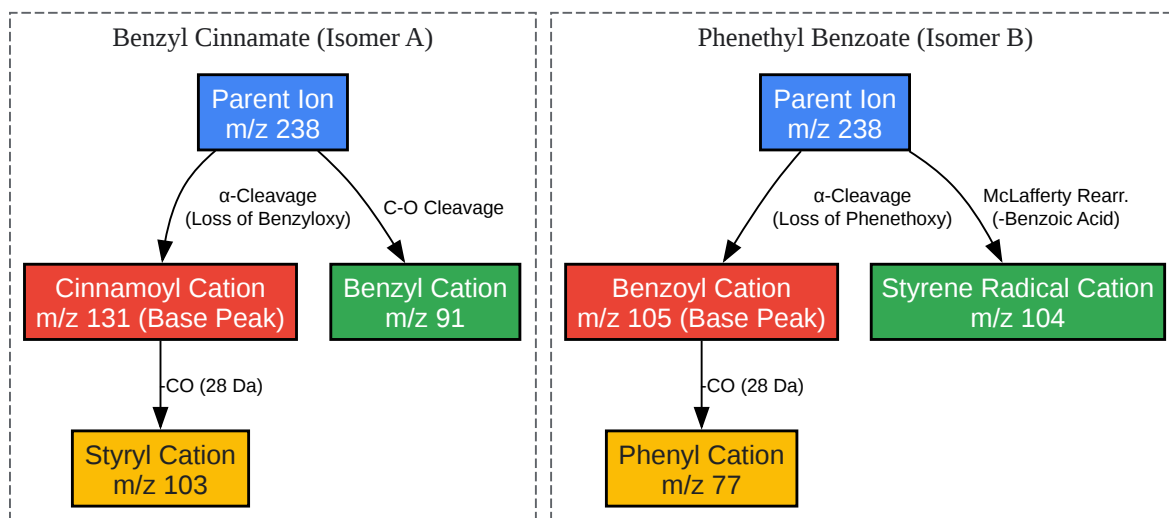

[Click to download full resolution via product page](#)

Caption: Comparative fragmentation pathways. Note the distinct Base Peaks (Red) and Rearrangement products (Green) that differentiate the isomers.

## Experimental Protocol: Self-Validating Workflow

To replicate these results, follow this standardized GC-MS methodology. This protocol includes a "System Suitability Test" (SST) to ensure the mass spectrometer is tuned to detect the critical m/z 104 vs 103 difference.

### A. Sample Preparation

- Solvent: Dilute sample to 100 ppm in Dichloromethane (DCM) or Hexane. Avoid Methanol (transesterification risk in injector).
- Standard: Spike with internal standard Dodecane (m/z 57, 71) for retention indexing.

### B. GC-MS Parameters (Agilent/Thermo Standard)

- Column: DB-5MS or equivalent (30m x 0.25mm x 0.25 $\mu$ m).

- Inlet: Split 20:1, 280°C.
- Carrier Gas: Helium at 1.0 mL/min (Constant Flow).
- Oven Program:
  - Hold 60°C for 1 min.
  - Ramp 20°C/min to 300°C.
  - Hold 5 min.
- Source Temp: 230°C (Critical: Higher temps promote fragmentation, lower temps preserve molecular ion).
- Ionization: EI, 70 eV.
- Scan Range: m/z 40–400.

## C. Data Interpretation Steps

- Check m/z 131 vs 105:
  - If Base Peak = 131  
Suspect Benzyl Cinnamate.
  - If Base Peak = 105  
Suspect Phenethyl Benzoate.
- Verify "The Neighbor":
  - Look for m/z 103. If present with 131  
Confirmed Cinnamate.
  - Look for m/z 104. If present with 105  
Confirmed Benzoate.

- Retention Index (RI) Check:
  - Benzyl Cinnamate RI  
2060-2080 (on DB-5).
  - Phenethyl Benzoate RI  
1850-1880 (on DB-5).
  - Note: Phenethyl benzoate elutes significantly earlier due to lower molecular linearity and boiling point.

## References

- NIST Mass Spectrometry Data Center. (2023). Benzyl cinnamate Mass Spectrum. NIST Chemistry WebBook, SRD 69.[2][3] Retrieved from [[Link](#)]
- NIST Mass Spectrometry Data Center. (2023). Benzoic acid, 2-phenylethyl ester Mass Spectrum. NIST Chemistry WebBook, SRD 69.[2][3] Retrieved from [[Link](#)]
- McLafferty, F. W., & Tureček, F. (1993). Interpretation of Mass Spectra (4th ed.).[4] University Science Books. (Standard text validating the McLafferty rearrangement mechanism in esters).

### Need Custom Synthesis?

BenchChem offers custom synthesis for rare earth carbides and specific isotopic labeling.

Email: [info@benchchem.com](mailto:info@benchchem.com) or [Request Quote Online](#).

## Sources

- 1. One moment, please... [[chemistrysteps.com](http://chemistrysteps.com)]
- 2. Benzoic acid, phenyl ester [[webbook.nist.gov](http://webbook.nist.gov)]
- 3. Benzyl cinnamate [[webbook.nist.gov](http://webbook.nist.gov)]
- 4. thiele.ruc.dk [[thiele.ruc.dk](http://thiele.ruc.dk)]

- To cite this document: BenchChem. [mass spectrometry fragmentation pattern of C16H16O2 esters]. BenchChem, [2026]. [Online PDF]. Available at: [<https://www.benchchem.com/product/b3873386/docs#mass-spectrometry-fragmentation-pattern-of-c16h16o2-esters>]

### Disclaimer & Data Validity:

The information provided in this document is for Research Use Only (RUO) and is strictly not intended for diagnostic or therapeutic procedures. While BenchChem strives to provide accurate protocols, we make no warranties, express or implied, regarding the fitness of this product for every specific experimental setup.

**Technical Support:** The protocols provided are for reference purposes. Unsure if this reagent suits your experiment?

**Need Industrial/Bulk Grade?** [Request Custom Synthesis Quote](#)

## BenchChem

Our mission is to be the trusted global source of essential and advanced chemicals, empowering scientists and researchers to drive progress in science and industry.

### Contact

Address: 3281 E Guasti Rd  
Ontario, CA 91761, United States  
Phone: (601) 213-4426  
Email: [info@benchchem.com](mailto:info@benchchem.com)

[Contact our Ph.D. Support Team for a compatibility check](#)