

Advanced Characterization Guide: Mass Spectrometry Fragmentation of Dimethyl Bipiperidines

Author: BenchChem Technical Support Team. **Date:** May 2026

Compound of Interest

Compound Name: *1'-benzyl-3,5-dimethyl-1,4'-bipiperidine*
Cat. No.: *B3853245*

[Get Quote](#)

Executive Summary

Dimethyl bipiperidines (C₁₂H₂₄N₂, MW 196.34 Da) are critical structural impurities often encountered in the synthesis and degradation profiling of piperidine-based local anesthetics (e.g., bupivacaine, ropivacaine) and hydrogenation products of bipyridines. Their structural similarity to the parent drugs and the existence of multiple positional isomers (e.g., 2,2', 3,3', 4,4'-) make them analytically challenging.

This guide provides a technical comparison of the mass spectrometric behavior of dimethyl bipiperidines against their unmethylated and monomethylated counterparts. It focuses on distinguishing isomers through fragmentation mechanics, specifically contrasting bridge-cleavage versus ring-cleavage pathways.

Technical Deep Dive: Fragmentation Mechanics

The fragmentation of piperidine dimers is governed by the stability of the resulting iminium ions. The position of the linkage between the two rings (2,2' vs. 4,4') and the location of the methyl

groups dictate the dominant pathway.

Electron Ionization (EI) – The Hard Ionization Fingerprint

In EI (70 eV), the radical cation (

) directs fragmentation primarily through

-cleavage.

- Mechanism A: Bridge Cleavage (Diagnostic for 2,2'-Isomers) In 2,2'-bipiperidines, the C-C bond connecting the rings is to both nitrogen atoms. This bond is exceptionally labile. Ionization triggers homolytic cleavage at this bridge, splitting the molecule into two halves.
 - Result: A dominant base peak at m/z 98 (for symmetric dimethyl isomers) or a mix of m/z 84/112 (for asymmetric methylation).
- Mechanism B: Ring Cleavage (Diagnostic for 3,3'- and 4,4'-Isomers) In 4,4'-bipiperidines, the bridge is to the nitrogens. The radical site on the nitrogen cannot stabilize a bridge cleavage. Instead, -cleavage occurs within the piperidine ring (endocyclic cleavage), leading to loss of alkyl radicals (e.g., methyl, ethyl) or ring opening.
 - Result: The molecular ion (, m/z 196) is more abundant; the "half-molecule" ion is weak or absent.

Electrospray Ionization (ESI) – The Soft Ionization Fingerprint

In ESI (+ve mode), the species is the protonated molecule

. Collision-Induced Dissociation (CID) drives fragmentation via charge-remote or charge-proximate mechanisms.

- Neutral Loss: Loss of

(17 Da) is common in piperidines, yielding m/z 180.

- Retro-Diels-Alder (RDA): High-energy collisions can induce ring opening, often observed as losses of

(28 Da) or

(42 Da).

Visualization of Fragmentation Pathways

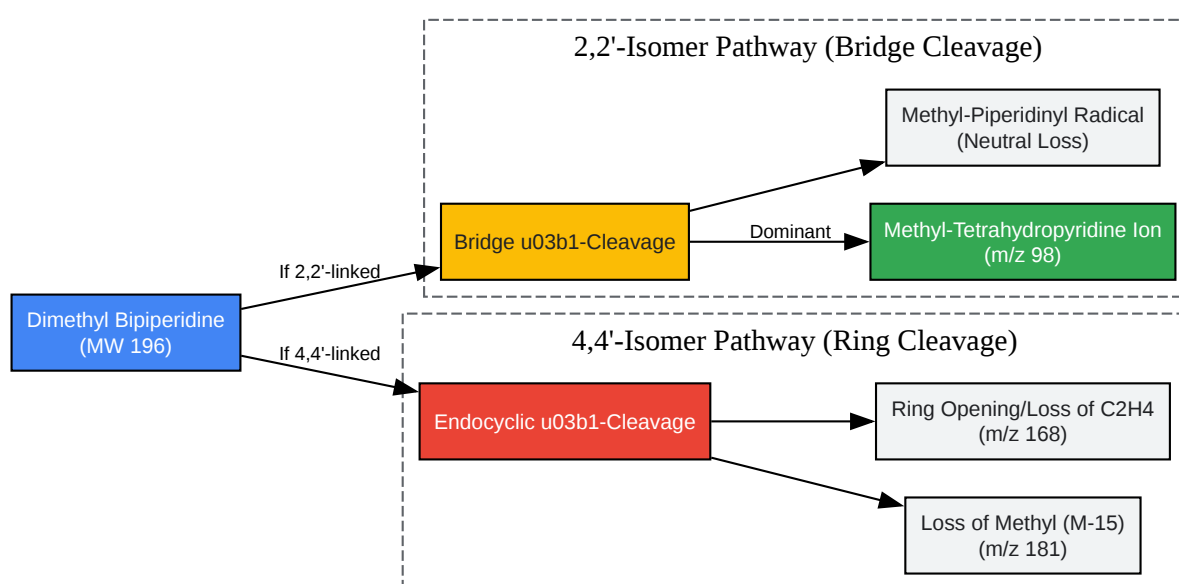

[Click to download full resolution via product page](#)

Figure 1: Mechanistic divergence in fragmentation between 2,2'- and 4,4'-dimethyl bipiperidine isomers.

Comparative Analysis: Product Performance

The following data compares the dimethyl variant against the unsubstituted parent and monomethyl intermediate. This data is essential for identifying the degree of methylation in unknown impurities.

Table 1: Diagnostic Ion Comparison (EI Mode)

Compound Class	Molecular Ion ()	Base Peak (100%)	Key Diagnostic Fragments	Mechanistic Insight
Bipiperidine (Unsubstituted)	m/z 168	m/z 84	m/z 168, 84, 55	Symmetric cleavage at C2-C2' bridge yields intense m/z 84 monomer.
Monomethyl Bipiperidine	m/z 182	m/z 84 or 98	m/z 182, 98, 84	Asymmetric cleavage. Ratio of m/z 98 to 84 indicates methyl position.
Dimethyl Bipiperidine (Target)	m/z 196	m/z 98	m/z 196, 181, 98, 55	m/z 98 confirms methylation on both rings (if symmetric). m/z 181 indicates methyl loss.

Table 2: Isomer Differentiation (Performance Metrics)

Feature	2,2'-Dimethyl Isomer	4,4'-Dimethyl Isomer
Bridge Stability	Low (Labile)	High (Stable)
Dominant Fragment	m/z 98 (Monomer)	m/z 196 () or m/z 181 ()
Spectrum Complexity	Simple (dominated by monomer)	Complex (many ring-fragment ions)
Differentiation Strategy	Look for base peak at M/2.[1][2]	Look for strong molecular ion and M-15/M-29.

Validated Experimental Protocols

To ensure reproducibility and trust in your data, follow these self-validating protocols.

Protocol A: LC-MS/MS (ESI) for Impurity Profiling

Best for: Trace analysis in biological matrices or drug formulations.

- Sample Prep: Dissolve sample in 50:50 Methanol:Water + 0.1% Formic Acid to 1 µg/mL.
- Column: C18 Reverse Phase (e.g., 2.1 x 100 mm, 1.8 µm).
 - Why: Piperidines are basic; C18 retains them well at high pH, but low pH (formic acid) is needed for ESI efficiency.
- Mobile Phase:
 - A: 0.1% Formic Acid in Water.[3]
 - B: 0.1% Formic Acid in Acetonitrile.[3]
- MS Settings (Q-TOF or Triple Quad):
 - Source: ESI Positive.
 - Capillary Voltage: 3.0 kV.
 - Self-Validation Step: Infuse a known standard of Bupivacaine (m/z 289). Ensure signal stability <5% RSD before injecting unknowns.
- Data Acquisition: Perform Product Ion Scan of precursor m/z 197.2 (
)
 - Collision Energy (CE): Ramp 20–40 eV.
 - Target: Monitor transition 197 -> 98 (Bridge cleavage) vs 197 -> 180 (Ammonia loss).

Protocol B: GC-MS (EI) for Structural Elucidation

Best for: Isomer differentiation and library matching.

- Derivatization (Optional): If peak tailing occurs due to the secondary amine, derivatize with TFAA (Trifluoroacetic anhydride).
 - Note: This adds 192 Da (two trifluoroacetyl groups) to the MW.
- GC Parameters:
 - Column: HP-5ms or equivalent (5% phenyl methyl siloxane).
 - Inlet: 250°C, Split 10:1.
 - Temp Program: 60°C (1 min) -> 20°C/min -> 300°C.
- MS Parameters:
 - Source: 230°C, 70 eV.
 - Scan Range: m/z 40–300.
- Interpretation Logic:
 - Step 1: Check Molecular Ion.^[4] Is it 196? (Yes = Dimethyl Bipyridine).
 - Step 2: Check Base Peak.^{[4][5]}
 - If 98: Assign as 2,2'-isomer (Symmetric cleavage).
 - If 196 is strong and 98 is weak (<20%): Assign as 3,3' or 4,4'-isomer.

References

- NIST Chemistry WebBook. 2,2'-Bipyridine, 4,4'-dimethyl- Mass Spectrum (EI). (Note: Aromatic precursor often used as reference for substitution patterns). Available at: [\[Link\]](#)
- PubChem. Compound Summary: 4,4'-Dimethyl-2,2'-bipyridine.^{[1][2][6][7][8][9][10]} National Library of Medicine. Available at: [\[Link\]](#)

- PureSynth.4,4'-Dimethyl-2,2'-bipiperidine Product Specifications. (Confirmation of commercial availability of specific isomers). Available at: [\[Link\]](#)

Need Custom Synthesis?

BenchChem offers custom synthesis for rare earth carbides and specific isotopic labeling.

Email: info@benchchem.com or [Request Quote Online](#).

Sources

1. 2,2'-Bipyridine, 4,4'-dimethyl- [\[webbook.nist.gov\]](#)
 2. 4,4'-Dimethyl-2,2'-bipyridine | C₁₂H₁₂N₂ | CID 14338 - PubChem [\[pubchem.ncbi.nlm.nih.gov\]](#)
 3. [pdf.benchchem.com](#) [\[pdf.benchchem.com\]](#)
 4. [m.youtube.com](#) [\[m.youtube.com\]](#)
 5. [youtube.com](#) [\[youtube.com\]](#)
 6. 2,2'-Bipyridine, 4,4'-dimethyl- [\[webbook.nist.gov\]](#)
 7. 2,2'-Bipyridine, 4,4'-dimethyl- [\[webbook.nist.gov\]](#)
 8. 2,2'-Bipyridine, 4,4'-dimethyl- [\[webbook.nist.gov\]](#)
 9. 4,4'-Dimethyl-2,2'-bipyridine | C₁₂H₁₂N₂ | CID 14338 - PubChem [\[pubchem.ncbi.nlm.nih.gov\]](#)
 10. 2,2'-Bipyridine, 4,4'-dimethyl- [\[webbook.nist.gov\]](#)
- To cite this document: BenchChem. [Advanced Characterization Guide: Mass Spectrometry Fragmentation of Dimethyl Bipiperidines]. BenchChem, [2026]. [Online PDF]. Available at: [\[https://www.benchchem.com/product/b3853245/docs#advanced-characterization-guide-mass-spectrometry-fragmentation-of-dimethyl-bipiperidines\]](https://www.benchchem.com/product/b3853245/docs#advanced-characterization-guide-mass-spectrometry-fragmentation-of-dimethyl-bipiperidines)

Disclaimer & Data Validity:

The information provided in this document is for Research Use Only (RUO) and is strictly not intended for diagnostic or therapeutic procedures. While BenchChem strives to provide accurate protocols, we make no warranties, express or implied, regarding the fitness of this product for every specific experimental setup.

Technical Support: The protocols provided are for reference purposes. Unsure if this reagent suits your experiment?

Need Industrial/Bulk Grade? [Request Custom Synthesis Quote](#)

BenchChem

Our mission is to be the trusted global source of essential and advanced chemicals, empowering scientists and researchers to drive progress in science and industry.

Contact

Address: 3281 E Guasti Rd
Ontario, CA 91761, United States
Phone: (601) 213-4426
Email: info@benchchem.com

[Contact our Ph.D. Support Team for a compatibility check](#)