

# Air and moisture sensitivity of 2-Chloro-6-isopropylpyridine reactions

**Author:** BenchChem Technical Support Team. **Date:** January 2026

## Compound of Interest

Compound Name: 2-Chloro-6-isopropylpyridine

Cat. No.: B038974

[Get Quote](#)

## Technical Support Center: Reactions of 2-Chloro-6-isopropylpyridine

Welcome to the technical support center for reactions involving **2-Chloro-6-isopropylpyridine**. This guide is designed for researchers, scientists, and drug development professionals to navigate the complexities associated with the air and moisture sensitivity of this versatile reagent. Here, you will find in-depth troubleshooting guides and frequently asked questions (FAQs) to ensure the success of your experiments.

### I. Understanding the Challenge: The "Why" Behind Sensitivity

**2-Chloro-6-isopropylpyridine** is a valuable building block in organic synthesis, particularly in the construction of pharmaceutical intermediates and other complex molecules.<sup>[1]</sup> However, its successful application hinges on understanding and mitigating its sensitivity to atmospheric conditions. This sensitivity primarily arises from two key factors:

- **Hydrolysis of the C-Cl Bond:** The chloro-substituent on the pyridine ring is susceptible to hydrolysis, especially under basic or heated conditions, leading to the formation of the corresponding pyridone. This side reaction consumes the starting material and complicates purification. While 2-chloropyridine itself is not expected to readily hydrolyze under neutral environmental conditions, the elevated temperatures and basic reagents often employed in cross-coupling reactions can facilitate this undesired transformation.<sup>[2][3]</sup>

- **Catalyst Deactivation:** Many reactions utilizing **2-Chloro-6-isopropylpyridine**, such as Suzuki-Miyaura, Buchwald-Hartwig, and Heck couplings, rely on palladium catalysts. These catalysts are notoriously sensitive to both oxygen and moisture. Water can block the active sites of the palladium catalyst, leading to reduced catalytic activity or complete deactivation. [4][5] Oxygen can also lead to the oxidation of the active Pd(0) species, rendering it ineffective.[6]

## II. Frequently Asked Questions (FAQs)

Q1: My Suzuki-Miyaura coupling reaction with **2-Chloro-6-isopropylpyridine** is not proceeding, or the yield is very low. What are the likely causes?

A1: This is a common issue that can often be traced back to several factors related to air and moisture sensitivity:

- **Inactive Catalyst:** The primary suspect is often the deactivation of the palladium catalyst. 2-Chloropyridines are generally less reactive than their bromo or iodo counterparts, requiring a more active catalyst system.[7] If your catalyst has been exposed to air or moisture, its activity will be compromised.
- **Catalyst Inhibition:** The nitrogen atom in the pyridine ring can coordinate with the palladium center, inhibiting its catalytic activity. This is a known challenge with pyridine-containing substrates.[7][8]
- **Presence of Water:** Trace amounts of water in your solvents or reagents can hydrolyze the boronic acid starting material (protodeboronation) or deactivate the palladium catalyst.[4][7]
- **Inadequate Inert Atmosphere:** Insufficient purging of the reaction vessel with an inert gas (argon or nitrogen) can leave residual oxygen, which will deactivate the Pd(0) catalyst.[6]

Q2: I am observing a significant amount of 2-hydroxy-6-isopropylpyridine as a byproduct in my reaction. How can I prevent this?

A2: The formation of the corresponding pyridone is a clear indication of hydrolysis. To minimize this side reaction:

- **Rigorously Dry Solvents and Reagents:** Ensure all solvents are anhydrous and that any solid reagents are thoroughly dried before use.
- **Choice of Base:** The choice and handling of the base are critical. Some bases are hygroscopic and can introduce water into the reaction. Consider using a non-hygroscopic base or drying the base before use.
- **Reaction Temperature:** While elevated temperatures are often necessary to drive the reaction, excessively high temperatures can accelerate the rate of hydrolysis. Optimize the temperature to find a balance between reaction rate and byproduct formation.

Q3: Can I use standard laboratory solvents without drying them for reactions with **2-Chloro-6-isopropylpyridine**?

A3: It is strongly discouraged. Many common laboratory solvents absorb a significant amount of water from the atmosphere.[9] For moisture-sensitive reactions, particularly those involving organometallic reagents or catalysts, using anhydrous solvents is essential for reproducibility and high yields. The water content in solvents should ideally be below 50 ppm.[10]

Q4: What is the best way to handle and store **2-Chloro-6-isopropylpyridine**?

A4: While **2-Chloro-6-isopropylpyridine** is relatively stable under normal conditions, it is good practice to store it in a tightly sealed container in a cool, dry place away from direct sunlight.[11] For long-term storage, consider storing it under an inert atmosphere (argon or nitrogen). When handling the reagent, minimize its exposure to the atmosphere.

### III. Troubleshooting Guides

This section provides structured guidance to diagnose and resolve common issues encountered during reactions with **2-Chloro-6-isopropylpyridine**.

## Troubleshooting Low or No Yield in Palladium-Catalyzed Cross-Coupling Reactions

Symptom	Potential Cause	Recommended Action
No reaction or very low conversion of starting material.	Deactivated Catalyst: Exposure of the palladium catalyst to air or moisture.	- Use a fresh batch of catalyst. - Ensure all transfers of the catalyst are done under a positive pressure of inert gas. - Consider using a pre-catalyst that is more air-stable.
Insufficiently Inert Atmosphere: Residual oxygen in the reaction vessel.	- Flame-dry or oven-dry all glassware immediately before use.[12] - Assemble the apparatus while hot and flush with a stream of inert gas. - Perform at least three vacuum/inert gas backfill cycles to thoroughly remove air.[13]	
Wet Solvents or Reagents: Introduction of water into the reaction.	- Use freshly dried and degassed solvents. - Dry all solid reagents (e.g., base, boronic acid) in a vacuum oven before use.	
Formation of significant byproducts (e.g., homocoupling, dehalogenation).	Presence of Oxygen: Can promote homocoupling of boronic acids.	- Degas solvents thoroughly using methods like freeze-pump-thaw or by bubbling with an inert gas for an extended period.[14]
Slow Transmetalation Step: Can lead to protodehalogenation.	- Optimize the base and solvent system to accelerate the desired catalytic cycle.[6]	

## Troubleshooting Grignard Reactions

Q: My Grignard reaction with **2-Chloro-6-isopropylpyridine** is failing. What should I check?

A: Grignard reagents are extremely sensitive to moisture and protic sources.[15]

- Incomplete Formation of Grignard Reagent: Ensure the magnesium turnings are activated and that the reaction to form the Grignard reagent is initiated successfully. A crystal of iodine can be used as an initiator.[16]
- Quenching of Grignard Reagent: Any trace of water in the solvent or on the glassware will quench the Grignard reagent.[17] Rigorous drying of all components is paramount.
- Reaction with the Pyridine Nitrogen: The Grignard reagent can potentially interact with the Lewis basic nitrogen of the pyridine ring.

## IV. Experimental Protocols and Methodologies

### Protocol 1: General Procedure for a Moisture-Sensitive Suzuki-Miyaura Coupling

This protocol outlines the key steps for performing a Suzuki-Miyaura coupling reaction with **2-Chloro-6-isopropylpyridine** under inert atmosphere conditions.

- Glassware Preparation:
  - All glassware (reaction flask, condenser, etc.) should be oven-dried at 125 °C for at least 24 hours or flame-dried under vacuum immediately before use.[9]
  - Assemble the apparatus while hot and allow it to cool under a positive flow of argon or nitrogen.
- Reagent and Solvent Preparation:
  - Solvents (e.g., 1,4-dioxane, toluene) must be anhydrous. Use a solvent purification system or distill from an appropriate drying agent (e.g., sodium/benzophenone for ethers, calcium hydride for hydrocarbons).[18][19]
  - Degas the solvent by bubbling with argon for 30-60 minutes or by using the freeze-pump-thaw method (three cycles).[14]

- Solid reagents (**2-Chloro-6-isopropylpyridine**, boronic acid, base, and catalyst) should be dried under vacuum if their purity is in question.
- Reaction Setup:
  - To the cooled, inerted reaction flask, add the palladium catalyst, ligand (if applicable), and base.
  - Add **2-Chloro-6-isopropylpyridine** and the boronic acid.
  - Evacuate the flask and backfill with inert gas. Repeat this cycle three times.[\[7\]](#)
  - Add the degassed solvent via syringe or cannula.[\[20\]](#)
- Reaction Execution and Workup:
  - Heat the reaction mixture to the desired temperature with vigorous stirring.
  - Monitor the reaction progress by TLC or LC-MS.
  - Upon completion, cool the reaction to room temperature.
  - Quench the reaction and perform a standard aqueous workup. Dry the organic layer over an anhydrous drying agent (e.g., Na<sub>2</sub>SO<sub>4</sub> or MgSO<sub>4</sub>), filter, and concentrate under reduced pressure.

## Visualization of Inert Atmosphere Technique: Schlenk Line Setup

The following diagram illustrates a standard Schlenk line setup for performing reactions under an inert atmosphere.

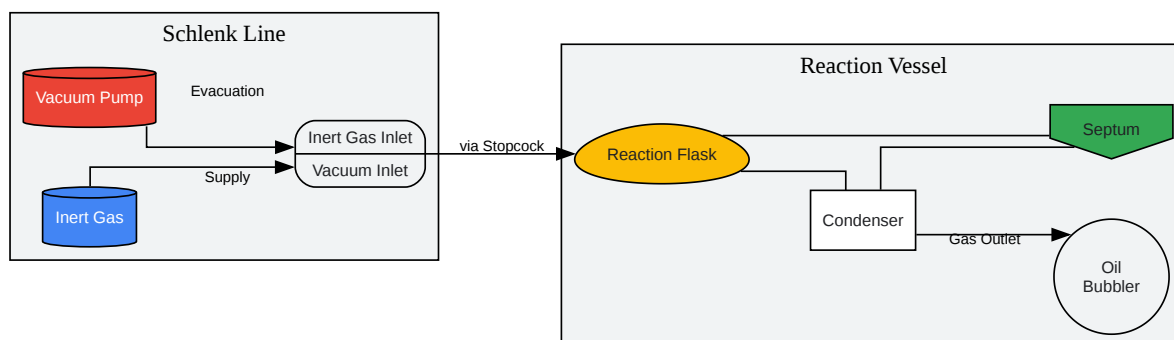

[Click to download full resolution via product page](#)

Caption: A typical Schlenk line setup for handling air- and moisture-sensitive reactions.

## V. Data Presentation

### Recommended Drying Agents for Common Solvents

Solvent	Primary Drying Agent(s)	Notes
Tetrahydrofuran (THF)	Sodium/Benzophenone	Benzophenone acts as an indicator (deep blue/purple color) for anhydrous conditions.
Toluene	Sodium/Benzophenone, Calcium Hydride (CaH <sub>2</sub> )	CaH <sub>2</sub> is a good choice for larger scale drying.
1,4-Dioxane	Sodium/Benzophenone	Similar to THF.
Acetonitrile	Calcium Hydride (CaH <sub>2</sub> ), then Phosphorus Pentoxide (P <sub>4</sub> O <sub>10</sub> )	Distillation from P <sub>4</sub> O <sub>10</sub> should be done with care.
Dichloromethane (DCM)	Calcium Hydride (CaH <sub>2</sub> )	Do not use sodium.

This table is a general guide. Always consult safety data sheets and relevant literature for specific drying procedures.

## VI. Concluding Remarks

The successful execution of reactions involving **2-Chloro-6-isopropylpyridine** is highly dependent on the meticulous exclusion of air and moisture. By understanding the underlying principles of its sensitivity and implementing rigorous experimental techniques, researchers can significantly improve reaction outcomes, enhance reproducibility, and avoid common pitfalls. This guide serves as a foundational resource, and further optimization may be necessary for specific applications.

## VII. References

- Role of Water on the Structure of Palladium for Complete Oxidation of Methane | ACS Catalysis. (2020). ACS Publications.
- Stability of palladium-based catalysts during catalytic combustion of methane: The influence of water. (2007). ResearchGate.
- Hydrolysis Kinetics for 2-Chloropyridine in Supercritical Water. (n.d.).
- 2-Chloropyridine | C<sub>5</sub>H<sub>4</sub>ClN. (n.d.). PubChem.
- Process for the production of 2-hydroxypyridine. (1990). Google Patents.
- Video: Preparing Anhydrous Reagents and Equipment. (2015). JoVE.
- Working with air and moisture sensitive compounds. (2008). Molecular Inorganic Chemistry.
- solvent drying and drying agents. (n.d.). Delloyd's Lab-Tech Chemistry resource.
- How to dry solvents for moisture-sensitive reactions with 2,3,6-Trimethoxyisonicotinaldehyde. (n.d.). Benchchem.
- Drying solvents. (2023). Sciencemadness Wiki.
- **2-Chloro-6-Isopropylpyridine** Manufacturer & Supplier China. (n.d.). Pipzine Chemicals.
- Unsuccessful Suzuki coupling with 2-chloro-3-aminopyridine troubleshooting. (n.d.). Benchchem.



- What are the possible ways to do a perfect inert atmosphere organic reaction without using glove box ?. (2015). ResearchGate.
- Inert atmosphere reactions. (2022). Chemistry Online.
- Inert Atmosphere. (2022). YouTube.
- A Comparative Guide to the Reactivity of 2-Chloropyridine Isomers in Palladium-Catalyzed Reactions. (n.d.). Benchchem.
- A Comparative Guide to Palladium Catalysts for the Cross-Coupling of 2-Chloropyridine-3-boronic Acid. (n.d.). Benchchem.
- troubleshooting common issues in reactions involving 2,6-Dichloropyridine. (n.d.). Benchchem.
- Reactions of Grignard Reagents. (2015). Master Organic Chemistry.
- Grignard Reaction, Mechanism, Reagent and Cheat Sheet. (2020). Leah4Sci.
- Application Notes and Protocols: Grignard Reaction with 2-Chloro-6-fluorobenzaldehyde. (n.d.). Benchchem.
- The Art of Custom Synthesis: Leveraging 2-Chloro-6-methylpyridine. (n.d.). NINGBO INNO PHARMCHEM CO.,LTD.

### *Need Custom Synthesis?*

*BenchChem offers custom synthesis for rare earth carbides and specific isotopic labeling.*

*Email: [info@benchchem.com](mailto:info@benchchem.com) or [Request Quote Online](#).*

## Sources

- 1. nbinno.com [nbinno.com]
- 2. 2-Chloropyridine | C<sub>5</sub>H<sub>4</sub>CIN | CID 7977 - PubChem [pubchem.ncbi.nlm.nih.gov]

- 3. US4942239A - Process for the production of 2-hydroxypyridine - Google Patents [patents.google.com]
- 4. pubs.acs.org [pubs.acs.org]
- 5. researchgate.net [researchgate.net]
- 6. pdf.benchchem.com [pdf.benchchem.com]
- 7. pdf.benchchem.com [pdf.benchchem.com]
- 8. pdf.benchchem.com [pdf.benchchem.com]
- 9. Video: Preparing Anhydrous Reagents and Equipment [jove.com]
- 10. pdf.benchchem.com [pdf.benchchem.com]
- 11. 2-Chloro-6-Isopropylpyridine Manufacturer & Supplier China | CAS 1507-24-8 | High Purity, Safety Data, Applications & Price [pipzine-chem.com]
- 12. youtube.com [youtube.com]
- 13. researchgate.net [researchgate.net]
- 14. molan.wdfiles.com [molan.wdfiles.com]
- 15. masterorganicchemistry.com [masterorganicchemistry.com]
- 16. pdf.benchchem.com [pdf.benchchem.com]
- 17. leah4sci.com [leah4sci.com]
- 18. Drying solvents and Drying agents [delloyd.50megs.com]
- 19. Drying solvents - Sciencemadness Wiki [sciencemadness.org]
- 20. chemistry-online.com [chemistry-online.com]
- To cite this document: BenchChem. [Air and moisture sensitivity of 2-Chloro-6-isopropylpyridine reactions]. BenchChem, [2026]. [Online PDF]. Available at: [https://www.benchchem.com/product/b038974#air-and-moisture-sensitivity-of-2-chloro-6-isopropylpyridine-reactions]

---

### Disclaimer & Data Validity:

The information provided in this document is for Research Use Only (RUO) and is strictly not intended for diagnostic or therapeutic procedures. While BenchChem strives to provide accurate protocols, we make no warranties, express or implied, regarding the fitness of this product for every specific experimental setup.

**Technical Support:** The protocols provided are for reference purposes. Unsure if this reagent suits your experiment? [[Contact our Ph.D. Support Team for a compatibility check](#)]

**Need Industrial/Bulk Grade?** [Request Custom Synthesis Quote](#)

## BenchChem

Our mission is to be the trusted global source of essential and advanced chemicals, empowering scientists and researchers to drive progress in science and industry.

### Contact

Address: 3281 E Guasti Rd  
Ontario, CA 91761, United States  
Phone: (601) 213-4426  
Email: [info@benchchem.com](mailto:info@benchchem.com)