

"comparative toxicology of substituted chlorophenols"

Author: BenchChem Technical Support Team. **Date:** April 2026

Compound of Interest

Compound Name: ethyl 2-(3-chlorophenoxy)-2-methylpropanoate

CAS No.: 59227-82-6

Cat. No.: B3748983

[Get Quote](#)

A Comparative Guide to the Toxicology of Substituted Chlorophenols for Researchers and Drug Development Professionals.

Introduction: The Double-Edged Sword of Chlorination

Substituted chlorophenols (CPs) are a class of aromatic organic compounds in which one or more hydrogen atoms on the phenol ring have been replaced by chlorine atoms. Their widespread use as intermediates in the synthesis of pesticides, herbicides, and dyes has led to their persistence in the environment, raising significant toxicological concerns. The toxicity of these compounds is not uniform; it is intricately linked to the number and position of chlorine atoms on the phenolic ring. This guide provides a comparative analysis of the toxicology of substituted chlorophenols, delving into the structure-activity relationships that govern their potency, their primary mechanisms of action, and the standardized methodologies used for their evaluation. By understanding these nuances, researchers can better predict the toxic potential of novel chlorinated compounds and develop strategies for risk assessment and mitigation.

Chapter 1: The Chemical Landscape and Its Toxicological Implications

The toxicity of chlorophenols is fundamentally dictated by their physicochemical properties, which are, in turn, determined by the degree and position of chlorine substitution. Two key properties are paramount:

- **Lipophilicity:** The addition of chlorine atoms progressively increases the lipophilicity (fat-solubility) of the molecule, often quantified by the octanol-water partition coefficient (log Kow). Increased lipophilicity enhances the ability of a chlorophenol to cross biological membranes and accumulate in lipid-rich tissues, generally leading to greater bioavailability and toxicity.
- **Acidity (pKa):** Phenol is a weak acid. The electron-withdrawing nature of chlorine atoms increases the acidity of the hydroxyl group (lowers the pKa). This is crucial because the toxicity of many chlorophenols is primarily exerted by their ionized (phenolate) form. A lower pKa means the compound will be more ionized at physiological pH, influencing its ability to interact with biological targets.

The interplay between these two factors creates a complex, non-linear relationship between structure and toxicity. While lipophilicity increases with the number of chlorines, the specific position of the chlorine atoms fine-tunes the molecule's steric and electronic properties, leading to significant differences in toxicity even among isomers.

Chapter 2: Unraveling the Mechanism: Oxidative Phosphorylation Uncoupling

The primary mechanism of acute toxicity for many substituted chlorophenols, particularly the higher chlorinated congeners like pentachlorophenol (PCP), is the uncoupling of oxidative phosphorylation in mitochondria.

The Process:

- **Proton Shuttle:** In their protonated (undissociated) form, lipophilic chlorophenols readily diffuse across the inner mitochondrial membrane into the mitochondrial matrix, which has a higher pH.

- Ionization: Once in the alkaline matrix, the chlorophenol releases its proton (H^+), becoming a phenolate anion.
- Disruption of Proton Gradient: This process effectively shuttles protons from the intermembrane space back into the matrix, bypassing the ATP synthase complex. This dissipates the critical proton-motive force that drives the synthesis of ATP.
- Cellular Energy Crisis: The cell's energy production is severely hampered. To compensate, the electron transport chain works faster, consuming oxygen at an accelerated rate without corresponding ATP production. This leads to hyperthermia, cellular exhaustion, and ultimately, cell death.

The efficiency of a chlorophenol as an uncoupler is directly related to its pKa. Compounds with a pKa close to physiological pH are often the most potent uncouplers because they can efficiently cycle between their protonated and deprotonated states across the mitochondrial membrane.

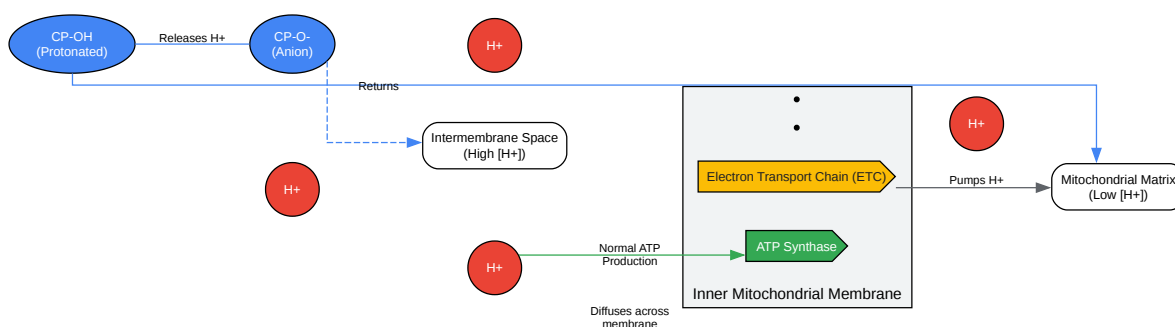

Figure 1: Mechanism of Oxidative Phosphorylation Uncoupling by Chlorophenols

[Click to download full resolution via product page](#)

Caption: Figure 1: Mechanism of Oxidative Phosphorylation Uncoupling by Chlorophenols.

Chapter 3: Comparative Toxicological Data

The toxicity of substituted chlorophenols generally increases with the number of chlorine substituents. This trend is evident across various toxicological endpoints, from acute toxicity in mammals to ecotoxicity in aquatic organisms. Pentachlorophenol (PCP) is consistently among the most toxic congeners. However, the position of the chlorine atoms also plays a critical role, with ortho-substituted chlorophenols often exhibiting different toxicological profiles compared to meta- or para-substituted isomers due to steric hindrance and altered electronic effects.

Table 1: Comparative Acute Toxicity of Selected Chlorophenols in Rats (Oral LD50)

Compound	CAS Number	Number of Chlorine Atoms	Oral LD50 (mg/kg)	Relative Toxicity
2-Chlorophenol	95-57-8	1	670	Low
4-Chlorophenol	106-48-9	1	670	Low
2,4-Dichlorophenol	120-83-2	2	580	Moderate
2,4,6-Trichlorophenol	88-06-2	3	820	Moderate
Pentachlorophenol	87-86-5	5	27-140	High

Data compiled from various toxicological databases. LD50 values can vary based on the study protocol, vehicle, and animal strain.

Beyond acute toxicity, higher chlorinated phenols like PCP are classified as probable human carcinogens (Group 2B) by the International Agency for Research on Cancer (IARC). Their genotoxicity is complex; while they are not typically potent mutagens in bacterial assays, they can induce chromosomal aberrations and DNA damage in mammalian cells, often linked to the generation of reactive oxygen species during their metabolism.

Chapter 4: Standardized Protocols for Cytotoxicity Assessment

To compare the toxic potential of different substituted chlorophenols, standardized in vitro assays are indispensable. The MTT assay is a widely used colorimetric method to assess cell viability by measuring the metabolic activity of mitochondria.

Experimental Protocol: MTT Assay for Comparative Cytotoxicity

1. Objective: To determine the concentration-dependent cytotoxic effect (IC₅₀) of various substituted chlorophenols on a human cell line (e.g., HepG2).

2. Materials:

- HepG2 cells
- Dulbecco's Modified Eagle Medium (DMEM) with 10% Fetal Bovine Serum (FBS)
- Substituted chlorophenols (e.g., 2-CP, 2,4-DCP, PCP) dissolved in DMSO (100 mM stock)
- MTT (3-(4,5-dimethylthiazol-2-yl)-2,5-diphenyltetrazolium bromide) solution (5 mg/mL in PBS)
- Dimethyl sulfoxide (DMSO)
- 96-well microplates
- Multi-channel pipette, incubator, microplate reader

3. Step-by-Step Methodology:

- Cell Seeding: Seed HepG2 cells into a 96-well plate at a density of 1×10^4 cells/well in 100 μ L of complete medium. Incubate for 24 hours at 37°C, 5% CO₂ to allow for cell attachment.
- Compound Preparation & Dosing:
 - Prepare a serial dilution of each chlorophenol stock solution in culture medium to achieve final concentrations ranging from 0.1 μ M to 1000 μ M.

- Causality Check: The choice of a wide concentration range is crucial to capture the full dose-response curve and accurately determine the IC50 value.
- Include a "vehicle control" (medium with the highest concentration of DMSO used, typically <0.5%) and a "no-cell" blank control.
- Cell Treatment: After 24 hours, carefully remove the old medium and add 100 µL of the medium containing the respective chlorophenol concentrations (or controls) to each well. Incubate for another 24 hours.
- MTT Addition: Add 10 µL of the 5 mg/mL MTT solution to each well. Incubate for 4 hours.
 - Mechanism Insight: During this time, mitochondrial dehydrogenases in living cells will cleave the tetrazolium ring of MTT, yielding insoluble purple formazan crystals. The amount of formazan produced is directly proportional to the number of viable cells.
- Formazan Solubilization: Carefully remove the MTT-containing medium and add 100 µL of DMSO to each well to dissolve the formazan crystals. Gently pipette to ensure complete solubilization.
- Data Acquisition: Measure the absorbance at 570 nm using a microplate reader.
- Data Analysis:
 - Subtract the average absorbance of the blank wells from all other readings.
 - Calculate cell viability as a percentage relative to the vehicle control: (% Viability) = $(\text{Absorbance}_{\text{treated}} / \text{Absorbance}_{\text{vehicle}}) * 100$.
 - Plot the % Viability against the log of the chlorophenol concentration and use non-linear regression to calculate the IC50 value (the concentration that inhibits 50% of cell viability).

Self-Validating System: This protocol incorporates essential controls for trustworthiness. The vehicle control ensures that the solvent (DMSO) does not contribute to toxicity, while the blank control corrects for background absorbance. Comparing the IC50 values obtained for different chlorophenols provides a quantitative measure of their relative cytotoxicity.

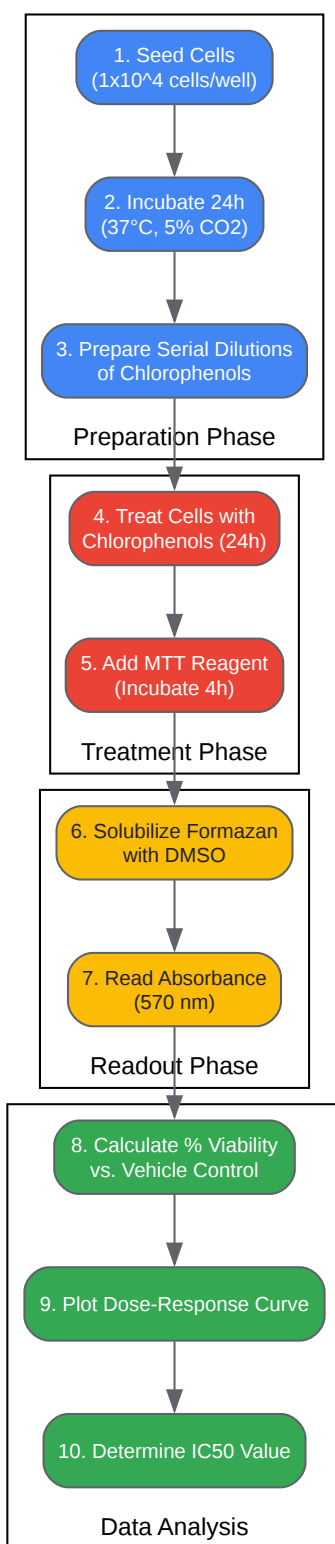

Figure 2: Experimental Workflow for the MTT Cytotoxicity Assay

[Click to download full resolution via product page](#)

Caption: Figure 2: Experimental Workflow for the MTT Cytotoxicity Assay.

Conclusion

The toxicology of substituted chlorophenols is a clear illustration of structure-activity relationships in toxicology. The general trend of increasing toxicity with increasing chlorination is primarily driven by enhanced lipophilicity and the potent ability of higher congeners to uncouple mitochondrial oxidative phosphorylation. However, this trend is modulated by the specific substitution pattern, which influences the compound's pKa and steric profile. For researchers in environmental science and drug development, a thorough understanding of these comparative principles is essential for predicting the toxicological profiles of chlorinated aromatic compounds, guiding the design of safer chemicals, and establishing robust risk assessment frameworks. The use of standardized in vitro assays, such as the MTT assay, provides a reliable and high-throughput method for quantifying and comparing the cytotoxic potential of these pervasive environmental contaminants.

References

- World Health Organization. (1987). Pentachlorophenol - Environmental Health Criteria 71. International Programme on Chemical Safety. [\[Link\]](#)
- Agency for Toxic Substances and Disease Registry (ATSDR). (2001). Toxicological Profile for Pentachlorophenol. U.S. Department of Health and Human Services. [\[Link\]](#)
- U.S. Environmental Protection Agency (EPA). (2010). Toxicological Review of Pentachlorophenol. Integrated Risk Information System (IRIS). [\[Link\]](#)
- National Center for Biotechnology Information. PubChem Compound Summary for Pentachlorophenol. [\[Link\]](#)
- International Agency for Research on Cancer (IARC). (2018). IARC Monographs on the Evaluation of Carcinogenic Risks to Humans, Volume 114: Pentachlorophenol and some related compounds. [\[Link\]](#)
- DeMarini, D. M., & Brooks, L. R. (2019). Genotoxicity of Pentachlorophenol and its Metabolites. *Reviews of Environmental Contamination and Toxicology*, 248, 1-35. [\[Link\]](#)
- [To cite this document: BenchChem. \["comparative toxicology of substituted chlorophenols"\]. BenchChem, \[2026\]. \[Online PDF\]. Available at:](#)

[\[https://www.benchchem.com/product/b3748983/docs#comparative-toxicology-of-substituted-chlorophenols\]](https://www.benchchem.com/product/b3748983/docs#comparative-toxicology-of-substituted-chlorophenols)

Disclaimer & Data Validity:

The information provided in this document is for Research Use Only (RUO) and is strictly not intended for diagnostic or therapeutic procedures. While BenchChem strives to provide accurate protocols, we make no warranties, express or implied, regarding the fitness of this product for every specific experimental setup.

Technical Support: The protocols provided are for reference purposes. Unsure if this reagent suits your experiment?

Need Industrial/Bulk Grade? [Request Custom Synthesis Quote](#)

BenchChem

Our mission is to be the trusted global source of essential and advanced chemicals, empowering scientists and researchers to drive progress in science and industry.

Contact

Address: 3281 E Guasti Rd
Ontario, CA 91761, United States
Phone: (601) 213-4426
Email: info@benchchem.com

[Contact our Ph.D. Support Team for a compatibility check](#)