

Celdion Technical Support Center: Mitigating Cytotoxicity

Author: BenchChem Technical Support Team. **Date:** April 2026

Compound of Interest

Compound Name: Celdion

Cat. No.: B373002

[Get Quote](#)

Welcome to the **Celdion** Technical Support Hub. This resource is designed for researchers, scientists, and drug development professionals to provide guidance on mitigating **Celdion**-induced cytotoxicity in cell lines. Here you will find troubleshooting guides, frequently asked questions (FAQs), and detailed experimental protocols to help you optimize your experiments and obtain reliable, reproducible data.

Understanding Celdion-Induced Cytotoxicity

Celdion is a potent and selective inhibitor of the novel kinase, K-STAR (Kinase Signal Transducer and Apoptosis Regulator). While highly effective at its primary target, supra-physiological concentrations in vitro can lead to off-target effects and subsequent cytotoxicity. This is often characterized by an increase in apoptosis and a decrease in overall cell viability. This guide will help you navigate these challenges.

Frequently Asked Questions (FAQs)

Q1: What is the primary mechanism of **Celdion**-induced cytotoxicity at high concentrations?

A1: At concentrations significantly above the IC50 for K-STAR, **Celdion** can inhibit several other kinases involved in cell survival pathways, including AKT and ERK. This off-target

inhibition disrupts the natural balance of pro-survival and pro-apoptotic signals, leading to the activation of the intrinsic apoptotic pathway, primarily through caspase-3 and caspase-7 activation.[1][2][3]

Q2: My cells appear stressed (e.g., rounded, detached) even at low concentrations of **Celdion**. What could be the cause?

A2: Several factors could contribute to this observation:

- **Cell Health:** Ensure your cells are healthy, within a low passage number, and in the logarithmic growth phase before treatment. Stressed or overly confluent cells are more susceptible to drug-induced toxicity.[4][5]
- **Solvent Toxicity:** **Celdion** is typically dissolved in DMSO. Ensure the final concentration of DMSO in your culture medium is below 0.5% (v/v), as higher concentrations can be cytotoxic to many cell lines.[6][7]
- **Cell Line Sensitivity:** Different cell lines exhibit varying sensitivities to **Celdion**. It is crucial to perform a dose-response experiment to determine the optimal concentration range for your specific cell line.[8][9]

Q3: Can I reduce **Celdion**'s cytotoxicity without compromising its on-target efficacy?

A3: Yes. The key is to use the lowest effective concentration that elicits the desired on-target effect.[10] Performing a careful dose-response analysis will help identify a therapeutic window where K-STAR is inhibited with minimal off-target cytotoxicity. Additionally, optimizing treatment duration can also mitigate toxicity.[6][7]

Troubleshooting Guide

Problem	Possible Cause(s)	Suggested Solution(s)
High variability between replicate wells in viability assays.	1. Inconsistent cell seeding density. 2. Uneven distribution of Celdion. 3. "Edge effects" in the microplate.[11]	1. Ensure a homogenous cell suspension before and during plating.[12] 2. Mix gently but thoroughly after adding Celdion to each well. 3. Avoid using the outer wells of the plate for experimental samples. Fill them with sterile PBS or media to maintain humidity.[11]
Viability in treated wells is greater than 100% of the control.	1. Pipetting errors leading to more cells in treated wells. 2. The compound may be stimulating cell proliferation at very low concentrations (a phenomenon known as hormesis).[13] 3. Interference of the compound with the assay reagents.	1. Use calibrated pipettes and ensure proper mixing of cell stock.[13] 2. Confirm this effect with a direct cell counting method (e.g., Trypan blue exclusion). 3. Run a control with Celdion in cell-free media to check for direct reaction with assay reagents.[11]
High background in apoptosis assays (e.g., Annexin V/PI).	1. Harsh cell handling (e.g., excessive centrifugation speed, vigorous vortexing). 2. Overly confluent or unhealthy cells at the start of the experiment. 3. Prolonged incubation with trypsin during cell detachment.	1. Handle cells gently. Centrifuge at low speeds (e.g., 200-300 x g). Do not vortex cell pellets.[14] 2. Use cells in their logarithmic growth phase. 3. Minimize trypsin exposure time and neutralize promptly.
Discrepancy between viability (e.g., MTT) and apoptosis (e.g., Caspase-Glo) data.	1. MTT assays measure metabolic activity, which may not always directly correlate with cell number, especially if Celdion affects mitochondrial function.[15] 2. Timing of the assays. Apoptosis is a	1. Use a viability assay based on a different principle, such as cell counting or ATP measurement (e.g., CellTiter-Glo). 2. Perform a time-course experiment to capture the peak of apoptotic activity.[8]

process, and different markers appear at different times.

Caspase activation is an earlier event than loss of membrane integrity.

Quantitative Data Summary

The following tables provide representative data for **Celdion**'s effects on two common cell lines: a sensitive cancer cell line (HeLa) and a less sensitive non-cancer cell line (HEK293).

Table 1: IC50 Values of **Celdion** after 48-hour treatment

Cell Line	IC50 (µM) for Viability (MTT Assay)	IC50 (µM) for K-STAR Inhibition	Therapeutic Index (Viability IC50 / K-STAR IC50)
HeLa	5.2	0.5	10.4
HEK293	25.8	1.2	21.5

Table 2: Apoptosis Induction by **Celdion** after 24-hour treatment

Cell Line	Celdion Conc. (µM)	% Apoptotic Cells (Annexin V+/PI-)	Caspase-3/7 Activity (Fold Change vs. Control)
HeLa	1	8.5%	2.1
HeLa	5	45.2%	8.7
HeLa	10	68.1%	15.3
HEK293	1	2.1%	1.2
HEK293	5	10.3%	2.5
HEK293	10	22.5%	4.1

Experimental Protocols

Protocol 1: Cell Viability Assessment using MTT Assay

This protocol is for assessing cell viability by measuring the metabolic activity of cells.[16][17][18]

Materials:

- 96-well flat-bottom plates
- **Celdion** stock solution (e.g., 10 mM in DMSO)
- Complete culture medium
- MTT (3-(4,5-dimethylthiazol-2-yl)-2,5-diphenyltetrazolium bromide) solution: 5 mg/mL in sterile PBS.[19]
- Solubilization solution: 10% SDS in 0.01 M HCl.[18]

Procedure:

- Cell Seeding: Seed cells in a 96-well plate at a pre-determined optimal density (e.g., 5,000-10,000 cells/well) in 100 μ L of complete culture medium. Incubate for 24 hours at 37°C, 5% CO₂.
- Compound Treatment: Prepare serial dilutions of **Celdion** in complete culture medium. Remove the medium from the wells and add 100 μ L of the medium containing the different concentrations of **Celdion**. Include untreated and vehicle (e.g., 0.1% DMSO) control wells.
- Incubation: Incubate for the desired exposure time (e.g., 24, 48, or 72 hours).
- MTT Addition: Add 10 μ L of the 5 mg/mL MTT solution to each well.[17]
- Incubation: Incubate the plate for 3-4 hours at 37°C, allowing viable cells to convert MTT to formazan crystals.[18]
- Solubilization: Add 100 μ L of solubilization solution to each well to dissolve the formazan crystals.[16]

- Data Acquisition: Mix gently on an orbital shaker for 15 minutes to ensure complete solubilization.[\[15\]](#)[\[19\]](#) Read the absorbance at 570 nm using a microplate reader.

Protocol 2: Apoptosis Detection using Annexin V and Propidium Iodide (PI) Staining

This protocol distinguishes between healthy, early apoptotic, and late apoptotic/necrotic cells via flow cytometry.

Materials:

- Annexin V-FITC Apoptosis Detection Kit (containing Annexin V-FITC, Propidium Iodide, and Binding Buffer)
- Cold 1X PBS
- Flow cytometry tubes

Procedure:

- Cell Treatment: Culture and treat cells with **Celdion** as desired in 6-well plates.
- Cell Harvesting: Collect both adherent and floating cells. For adherent cells, wash with PBS and detach using a gentle cell dissociation reagent (e.g., Trypsin-EDTA). Centrifuge all cells at 300 x g for 5 minutes.[\[14\]](#)
- Washing: Discard the supernatant and wash the cell pellet once with cold 1X PBS. Centrifuge again.
- Resuspension: Resuspend the cell pellet in 100 μ L of 1X Binding Buffer.
- Staining: Add 5 μ L of Annexin V-FITC and 5 μ L of PI staining solution to the cell suspension.[\[20\]](#)
- Incubation: Gently mix and incubate for 15-20 minutes at room temperature in the dark.[\[14\]](#)
- Dilution: Add 400 μ L of 1X Binding Buffer to each tube.

- Data Acquisition: Analyze the samples by flow cytometry within 1 hour.[14]
 - Healthy cells: Annexin V- / PI-
 - Early apoptotic cells: Annexin V+ / PI-
 - Late apoptotic/necrotic cells: Annexin V+ / PI+

Protocol 3: Caspase-3/7 Activity Measurement

This protocol measures the activity of key executioner caspases using a luminescent assay.[21]
[22][23]

Materials:

- Caspase-Glo® 3/7 Assay Kit (Promega or similar)
- White-walled 96-well plates suitable for luminescence measurements

Procedure:

- Assay Setup: Seed and treat cells with **Celdion** in a white-walled 96-well plate (100 µL final volume per well). Include appropriate blank and vehicle controls.
- Reagent Preparation: Reconstitute the Caspase-Glo® 3/7 Reagent according to the manufacturer's instructions. Allow it to equilibrate to room temperature before use.[24]
- Reagent Addition: Remove the plate from the incubator and allow it to equilibrate to room temperature. Add 100 µL of the prepared Caspase-Glo® 3/7 Reagent to each well.[23]
- Incubation: Mix the contents on a plate shaker at 300-500 rpm for 30 seconds. Incubate at room temperature for 1 to 3 hours, protected from light.
- Data Acquisition: Measure the luminescence of each well using a plate-reading luminometer. The luminescent signal is proportional to the amount of caspase-3/7 activity.[24]

Visualizations

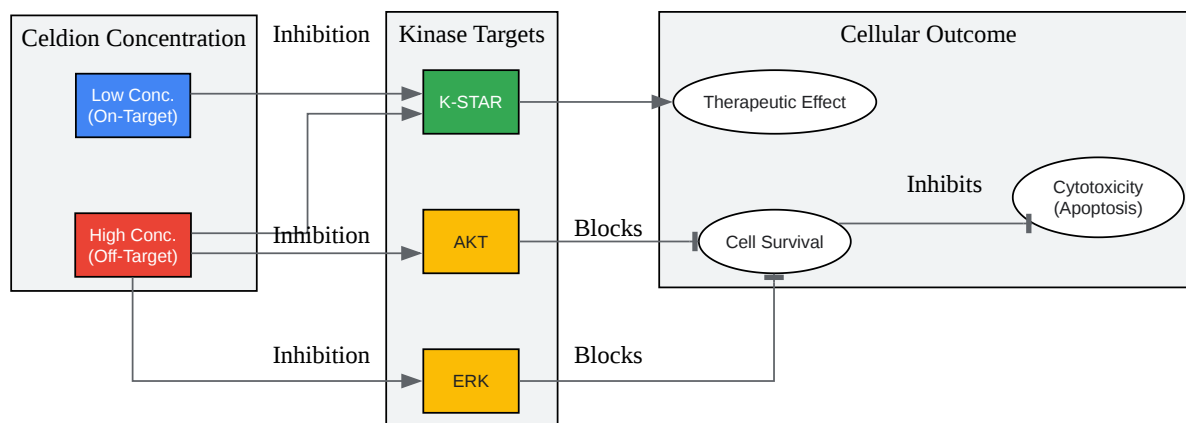

[Click to download full resolution via product page](#)

Caption: **Celdion's** dual effect on cell signaling pathways.

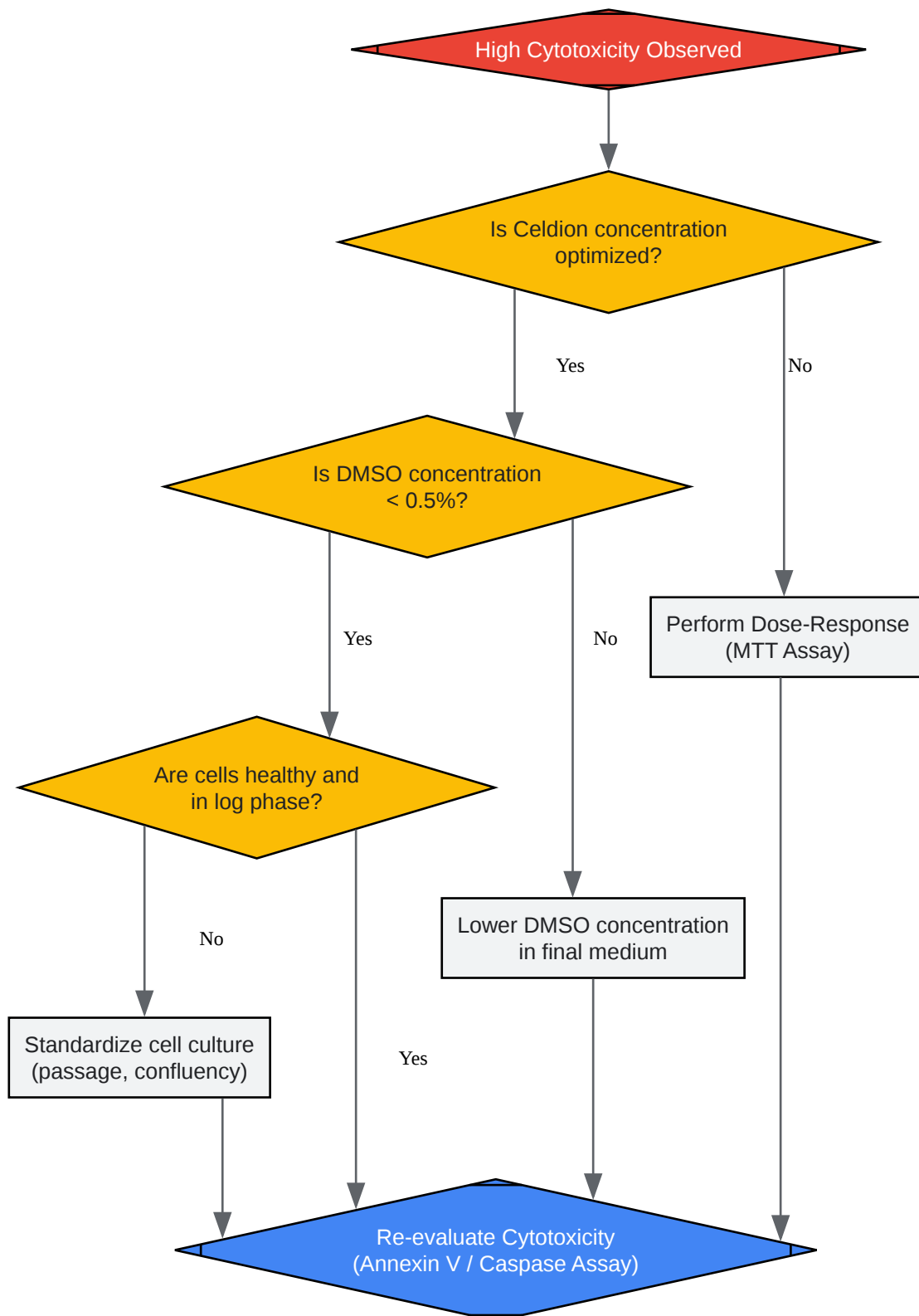

[Click to download full resolution via product page](#)

Caption: Workflow for troubleshooting **Celdion**-induced cytotoxicity.

Need Custom Synthesis?

BenchChem offers custom synthesis for rare earth carbides and specific isotopic labeling.

Email: info@benchchem.com or [Request Quote Online](#).

References

- [1. academic.oup.com](https://academic.oup.com) [academic.oup.com]
- [2. pubs.acs.org](https://pubs.acs.org) [pubs.acs.org]
- [3. Kinase inhibitors can produce off-target effects and activate linked pathways by retroactivity - PMC](#) [[pmc.ncbi.nlm.nih.gov](https://pubmed.ncbi.nlm.nih.gov)]
- [4. biocompare.com](https://biocompare.com) [biocompare.com]
- [5. benchchem.com](https://benchchem.com) [benchchem.com]
- [6. researchgate.net](https://researchgate.net) [researchgate.net]
- [7. bitesizebio.com](https://bitesizebio.com) [bitesizebio.com]
- [8. promegaconnections.com](https://promegaconnections.com) [promegaconnections.com]
- [9. sorger.med.harvard.edu](https://sorger.med.harvard.edu) [sorger.med.harvard.edu]
- [10. benchchem.com](https://benchchem.com) [benchchem.com]
- [11. benchchem.com](https://benchchem.com) [benchchem.com]
- [12. Cytotoxicity Assay Protocol & Troubleshooting - Creative Biolabs](#) [creativebiolabs.net]
- [13. researchgate.net](https://researchgate.net) [researchgate.net]
- [14. phnxflow.com](https://phnxflow.com) [phnxflow.com]
- [15. MTT assay protocol | Abcam](#) [abcam.com]
- [16. Cell Viability Assays - Assay Guidance Manual - NCBI Bookshelf](#) [[ncbi.nlm.nih.gov](https://pubmed.ncbi.nlm.nih.gov)]
- [17. MTT Assay Protocol for Cell Viability and Proliferation](#) [merckmillipore.com]
- [18. CyQUANT MTT Cell Proliferation Assay Kit Protocol | Thermo Fisher Scientific - SG](#) [thermofisher.com]
- [19. researchgate.net](https://researchgate.net) [researchgate.net]
- [20. Annexin V staining protocol for apoptosis : Abcam 제품 소개](#) [dawinbio.com]
- [21. Caspase-Glo® 3/7 Assay Protocol](#) [promega.jp]

- [22. Caspase 3/7 Activity \[protocols.io\]](#)
- [23. ulab360.com \[ulab360.com\]](#)
- [24. promega.com \[promega.com\]](#)
- To cite this document: BenchChem. [Celdion Technical Support Center: Mitigating Cytotoxicity]. BenchChem, [2026]. [Online PDF]. Available at: [<https://www.benchchem.com/product/b373002/docs#celdion-technical-support-center-mitigating-cytotoxicity>]

Disclaimer & Data Validity:

The information provided in this document is for Research Use Only (RUO) and is strictly not intended for diagnostic or therapeutic procedures. While BenchChem strives to provide accurate protocols, we make no warranties, express or implied, regarding the fitness of this product for every specific experimental setup.

Technical Support: The protocols provided are for reference purposes. Unsure if this reagent suits your experiment?

Need Industrial/Bulk Grade? [Request Custom Synthesis Quote](#)

BenchChem

Our mission is to be the trusted global source of essential and advanced chemicals, empowering scientists and researchers to drive progress in science and industry.

Contact

Address: 3281 E Guasti Rd
Ontario, CA 91761, United States
Phone: (601) 213-4426
Email: info@benchchem.com

[Contact our Ph.D. Support Team for a compatibility check](#)

