

# Minimizing background fluorescence in experiments with quinolinium probes

**Author:** BenchChem Technical Support Team. **Date:** April 2026

## Compound of Interest

Compound Name: *1-Ethyl-8-methylquinolinium*

Cat. No.: *B372588*

[Get Quote](#)

## Technical Support Center: Quinolinium Probe Experiments

A Guide to Minimizing Background Fluorescence & Maximizing Signal-to-Noise

Welcome, researchers. As a Senior Application Scientist, I've seen firsthand how high background fluorescence can obscure critical data and compromise experimental conclusions. Quinolinium-based probes are powerful tools, known for their environmental sensitivity and utility in applications ranging from pH sensing to imaging mitochondrial RNA.<sup>[1][2][3]</sup> However, their full potential is only realized when the signal-to-noise ratio (SNR) is maximized.

This guide is designed to move beyond simple checklists. It provides a framework for understanding the root causes of background noise and offers robust, field-tested strategies to mitigate them. We will explore the causality behind each experimental choice, empowering you to troubleshoot effectively and generate the highest quality data.

### Part 1: Frequently Asked Questions & Troubleshooting

This section addresses the most common issues encountered during experiments with quinolinium probes.

## Q1: What are the primary sources of background fluorescence in my experiment?

Understanding the origin of unwanted signal is the first step in eliminating it. Background fluorescence is rarely from a single source; it's typically a cumulative problem. The main contributors can be grouped into four categories:

- **Sample Autofluorescence:** This is fluorescence originating from endogenous molecules within your cells or tissue. Common culprits include metabolic coenzymes (NADH, flavins), structural proteins (collagen, elastin), and cellular aging pigments (lipofuscin).[\[4\]](#)[\[5\]](#)[\[6\]](#) This type of background is often most intense in the blue and green regions of the spectrum.[\[7\]](#)[\[8\]](#)
- **Reagent & Consumable Fluorescence:** The reagents and plastics you use can be highly fluorescent.
  - **Cell Culture Media:** Standard media often contain phenol red, a pH indicator that is highly fluorescent.[\[5\]](#)[\[9\]](#)[\[10\]](#)[\[11\]](#) Vitamins (like riboflavin) and components of fetal bovine serum (FBS) also contribute significantly to background.[\[4\]](#)[\[12\]](#)
  - **Plasticware:** Standard cell culture flasks and plates can have intrinsic fluorescence. For high-quality imaging, glass-bottom dishes are recommended.[\[4\]](#)[\[13\]](#)
  - **Fixatives & Mounting Media:** Aldehyde fixatives (formaldehyde, glutaraldehyde) can induce autofluorescence by reacting with cellular amines.[\[4\]](#)[\[14\]](#) Some mounting media can also be a source of background.[\[14\]](#)
- **Non-Specific Probe Binding & Unbound Probe:** This occurs when your quinolinium probe binds to unintended targets or when excess, unbound probe is not sufficiently washed away.[\[14\]](#)[\[15\]](#)[\[16\]](#) This often appears as a diffuse haze across the entire image.
- **System & Optical Noise:** This is background generated by the microscope itself. It can include stray light from the room or within the microscope's own optics, as well as electronic noise from the camera detector.[\[17\]](#)[\[18\]](#)

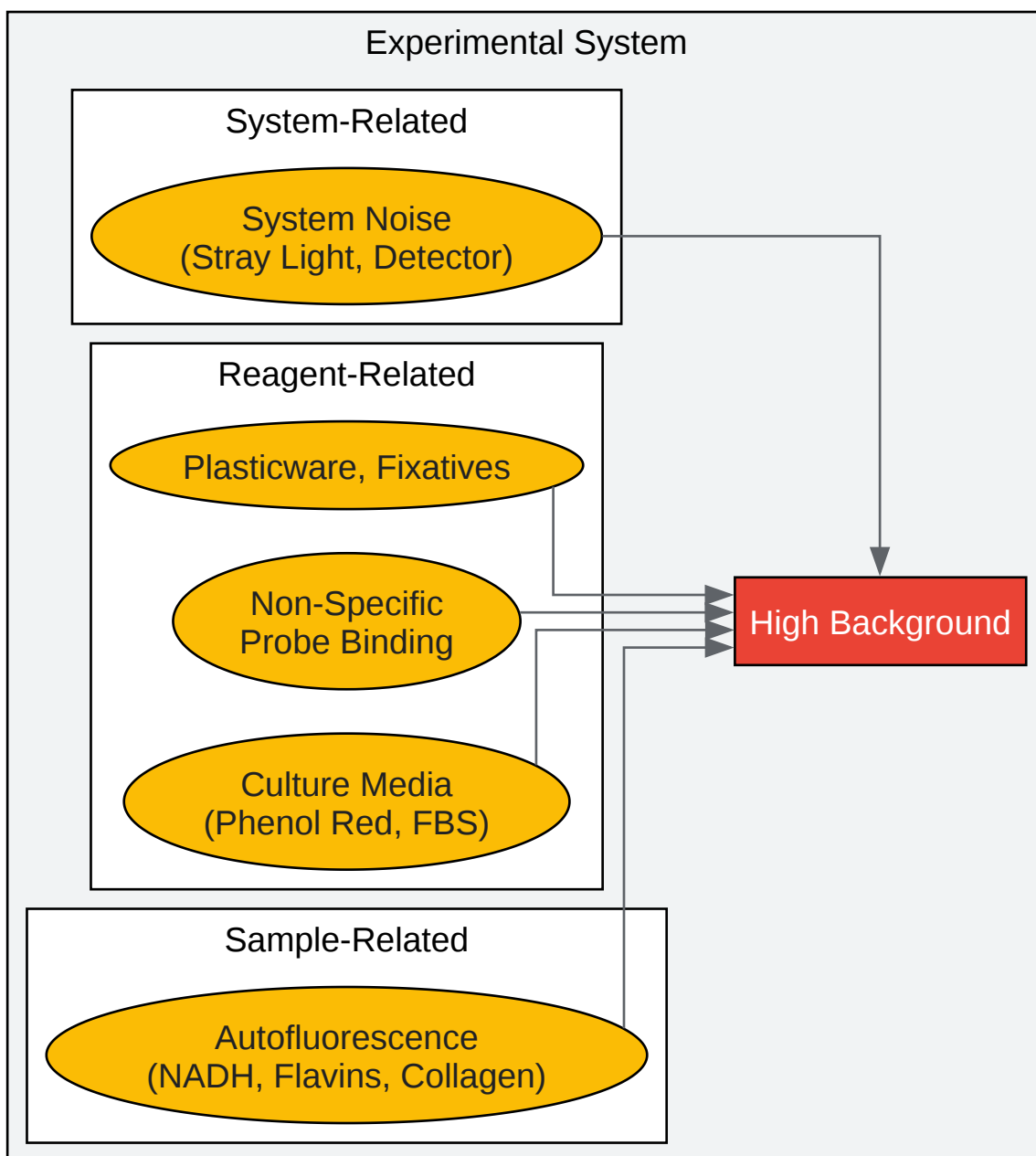

[Click to download full resolution via product page](#)

Caption: Major contributors to high background fluorescence.

Q2: My cell-free control (media + probe only) is extremely bright. How do I fix this?

This is a classic reagent-related issue. If your "blank" sample is fluorescent, the problem lies with your media or buffer.

The Cause: The primary culprit is almost always phenol red, a pH indicator present in most standard cell culture media.[11][19] Phenol red has a broad excitation and emission spectrum that can interfere with many fluorophores.[10] Additionally, components like riboflavin and amino acids in the media, as well as proteins in fetal bovine serum (FBS), are intrinsically fluorescent.[12] Exposing media to standard laboratory fluorescent lights can also degrade components and create new fluorescent species, further increasing background.[20]

The Solution:

- **Switch to Phenol Red-Free Media:** For the duration of the imaging experiment, replace the standard medium with a phenol red-free formulation. Many common media types (DMEM, MEM) are available in this format.[5][12]
- **Use an Imaging Buffer:** For short-term experiments (under 2-3 hours), the best practice is to remove the culture medium entirely and replace it with an optically clear, buffered salt solution like Hanks' Balanced Salt Solution (HBSS) or Phosphate-Buffered Saline (PBS).[5][13]
- **Consider Specialized Imaging Media:** For long-term live-cell imaging, use a medium specifically formulated for fluorescence microscopy, such as Gibco™ FluoroBrite™ DMEM.[9][13][21] These are designed to support cell health while containing minimal fluorescent components.
- **Reduce Serum Concentration:** If possible, reduce or eliminate FBS from the medium during the final probe incubation and imaging steps.[8][12]

Media/Buffer Component	Primary Issue	Recommended Action
Phenol Red	High intrinsic fluorescence, especially with blue/green excitation.[10]	Use phenol red-free media or switch to a buffered saline solution for imaging.[5]
Riboflavin (Vitamin B2)	Natural autofluorescence in the green channel.[4][9]	Use specialized low-fluorescence imaging media for long-term experiments.
Fetal Bovine Serum (FBS)	Contains fluorescent proteins and aromatic amino acids.[12]	Reduce or remove serum during imaging; wash cells thoroughly before adding probe.
HEPES Buffer	Can become phototoxic and produce hydrogen peroxide upon light exposure.[21]	If using a saline solution, prefer a bicarbonate-based buffer if your microscope has CO <sub>2</sub> control.

### Q3: My unstained cells are glowing, especially in the DAPI/FITC channels. How do I combat sample autofluorescence?

This indicates that your cells or tissue are the primary source of the background. This is particularly common in metabolically active cells, primary tissues rich in extracellular matrix, and samples that have been fixed with aldehydes.

**The Cause:** Cellular autofluorescence is dominated by mitochondrial flavins and NADH, which fluoresce in the blue and green parts of the spectrum.[4][6][22] In tissues, structural proteins like collagen and elastin are also major contributors.[6] Furthermore, aldehyde fixatives (e.g., formaldehyde) can cross-link proteins and create fluorescent adducts, significantly increasing background.[4][23]

**The Solution:**

- **Move to Redder Wavelengths:** This is the most effective strategy. Since most autofluorescence occurs between 350-550 nm, selecting a quinolinium probe that excites

and emits in the red or far-red spectrum (>600 nm) will spectrally separate your signal from the background.[7][8][13]

- Use a Chemical Quenching Agent (For Fixed Cells): After fixation and permeabilization, you can treat your samples to reduce autofluorescence.
  - Sodium Borohydride ( $\text{NaBH}_4$ ): This agent is effective at quenching aldehyde-induced autofluorescence.[8][14]
  - Sudan Black B: This dye can quench autofluorescence from lipofuscin, which are granules of pigmented waste products common in aging tissues.[14][24]
- Optimize Fixation: If your protocol allows, consider switching from aldehyde fixatives to an organic solvent like ice-cold methanol, which often results in lower autofluorescence.[4][8]

Objective: To reduce the background fluorescence caused by formaldehyde or glutaraldehyde fixation.

Materials:

- Phosphate-Buffered Saline (PBS)
- Sodium Borohydride ( $\text{NaBH}_4$ )
- Your fixed cell or tissue sample on a coverslip/slide

Procedure:

- Prepare Fresh Solution: Immediately before use, prepare a 0.1% (w/v) solution of Sodium Borohydride in PBS. (e.g., dissolve 10 mg of  $\text{NaBH}_4$  in 10 mL of PBS). Critical Step:  $\text{NaBH}_4$  is unstable in aqueous solutions, so it must be made fresh.
- Incubation: After completing your fixation and permeabilization steps, immerse your sample in the freshly prepared  $\text{NaBH}_4$  solution.
- Time: Incubate for 10-15 minutes at room temperature. You may see small bubbles form; this is normal.

- **Thorough Washing:** Wash the sample extensively to remove all traces of the quenching agent. Perform three washes with PBS, each for 5 minutes.[14]
- **Proceed with Staining:** You can now proceed with your blocking and quinolinium probe staining protocol.

## Q4: How can I optimize my staining protocol to improve the signal-to-noise ratio?

Even with the right buffers and low-autofluorescence samples, a suboptimal staining protocol can lead to high background from non-specific probe binding or residual unbound probe.

**The Cause:** Using too high a probe concentration is a common mistake; it saturates the specific binding sites and increases the amount of probe that binds non-specifically or remains trapped after washing.[7] Insufficient washing fails to remove this excess probe.[15][25]

**The Solution:** A systematic approach to optimization is key.

- **Titrate Your Probe:** Never assume the manufacturer's recommended concentration is optimal for your specific cell type and experimental conditions. Perform a concentration-response experiment, testing concentrations above and below the recommendation to find the sweet spot that provides bright specific staining with minimal background.[7][13]
- **Optimize Incubation Time:** Balance signal intensity with background. Shorter incubation times may be sufficient and can reduce non-specific uptake.
- **Enhance Your Wash Steps:** This is a critical and often overlooked step.
  - Increase the number of washes (3-4 washes are recommended).
  - Increase the duration of each wash (5 minutes per wash).
  - Add a mild, non-ionic detergent like 0.05% Tween-20 to your wash buffer to help remove non-specifically bound probe molecules.[14][16]
- **Include a Blocking Step:** While essential for immunofluorescence, a blocking step with a protein-based solution like Bovine Serum Albumin (BSA) can also reduce background for some fluorescent probes by occupying non-specific binding sites.[25][26]

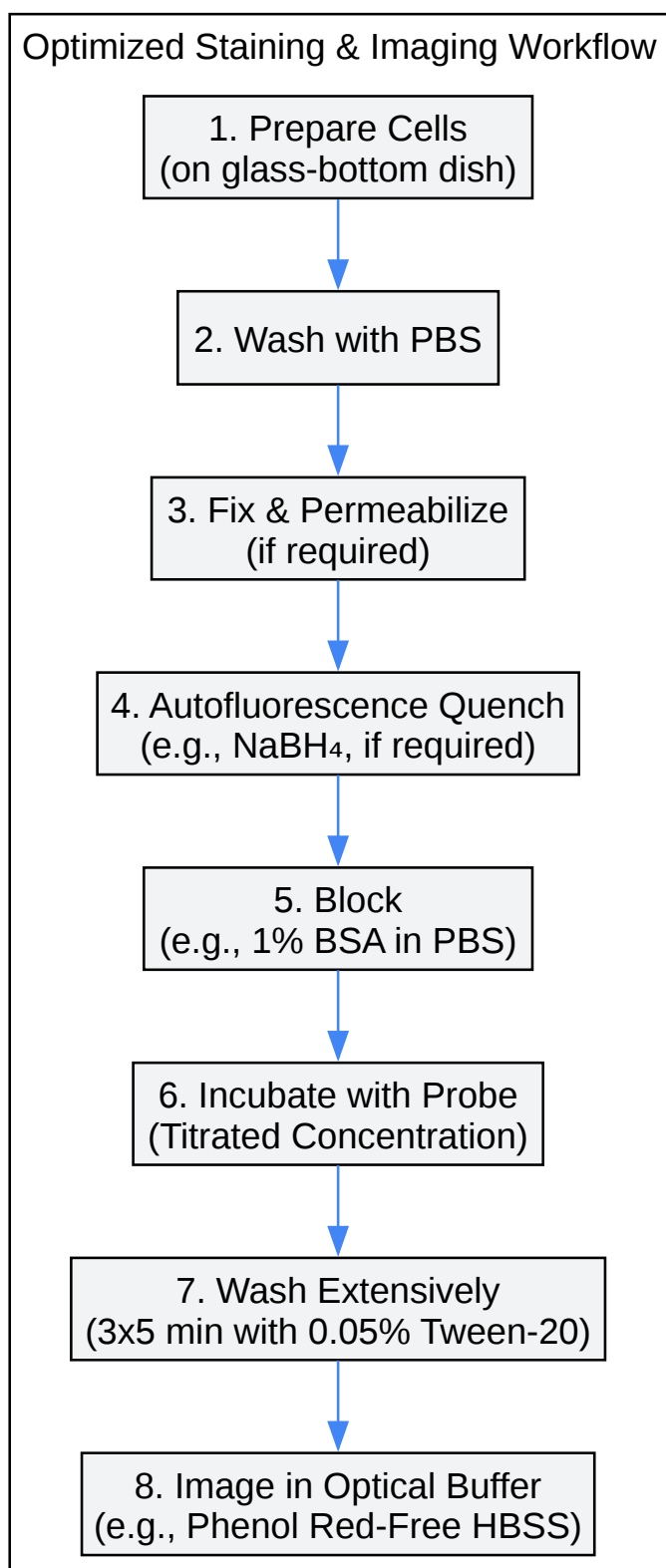

[Click to download full resolution via product page](#)

Caption: A sequential workflow for minimizing background.

## Q5: What microscope settings should I adjust to improve my images?

Your acquisition strategy can make a dramatic difference in the final signal-to-noise ratio (SNR). The goal is to maximize the collection of photons from your probe while minimizing photons from background sources and reducing detector noise.[27][28]

**The Cause:** Improper settings can either fail to capture a weak signal or, conversely, amplify background and noise to the point where the signal is obscured. For example, excessive laser power can increase autofluorescence and cause phototoxicity, while excessively high detector gain amplifies electronic noise along with the signal.

**The Solution:**

- **Balance Excitation Power and Exposure Time:** Instead of using high laser power, which can bleach your probe and increase autofluorescence, try using a lower, gentler excitation intensity and a longer camera exposure time.[28] This often improves SNR without damaging the sample.
- **Optimize Detector Gain/Voltage:** Find the lowest gain setting that still allows you to visualize your specific signal above the camera's read noise. Overly high gain will not create more signal, it will only make the image noisier.
- **Use the Optimal Pinhole Size (Confocal Microscopy):** The pinhole is key to rejecting out-of-focus light, which is a major component of background.[27] While a fully open pinhole collects more light, it also collects more background. Closing the pinhole increases background rejection but also discards some signal. The optimal setting (often around 1 Airy Unit) is a compromise that maximizes the SNR.[29]
- **Check Your Filters:** Ensure you are using high-quality bandpass filters that are tightly matched to your quinolinium probe's excitation and emission spectra. Poor-quality or mismatched filters can allow stray light and bleed-through, increasing background. In some cases, adding an extra emission filter can improve SNR by over 3-fold by cleaning up the signal path.[17][18]
- **Acquire Images with Sufficient Bit Depth:** Use a camera setting of 12-bit or 16-bit to capture the full dynamic range of your signal, preventing saturation of bright areas while still detecting dim signals above the background.

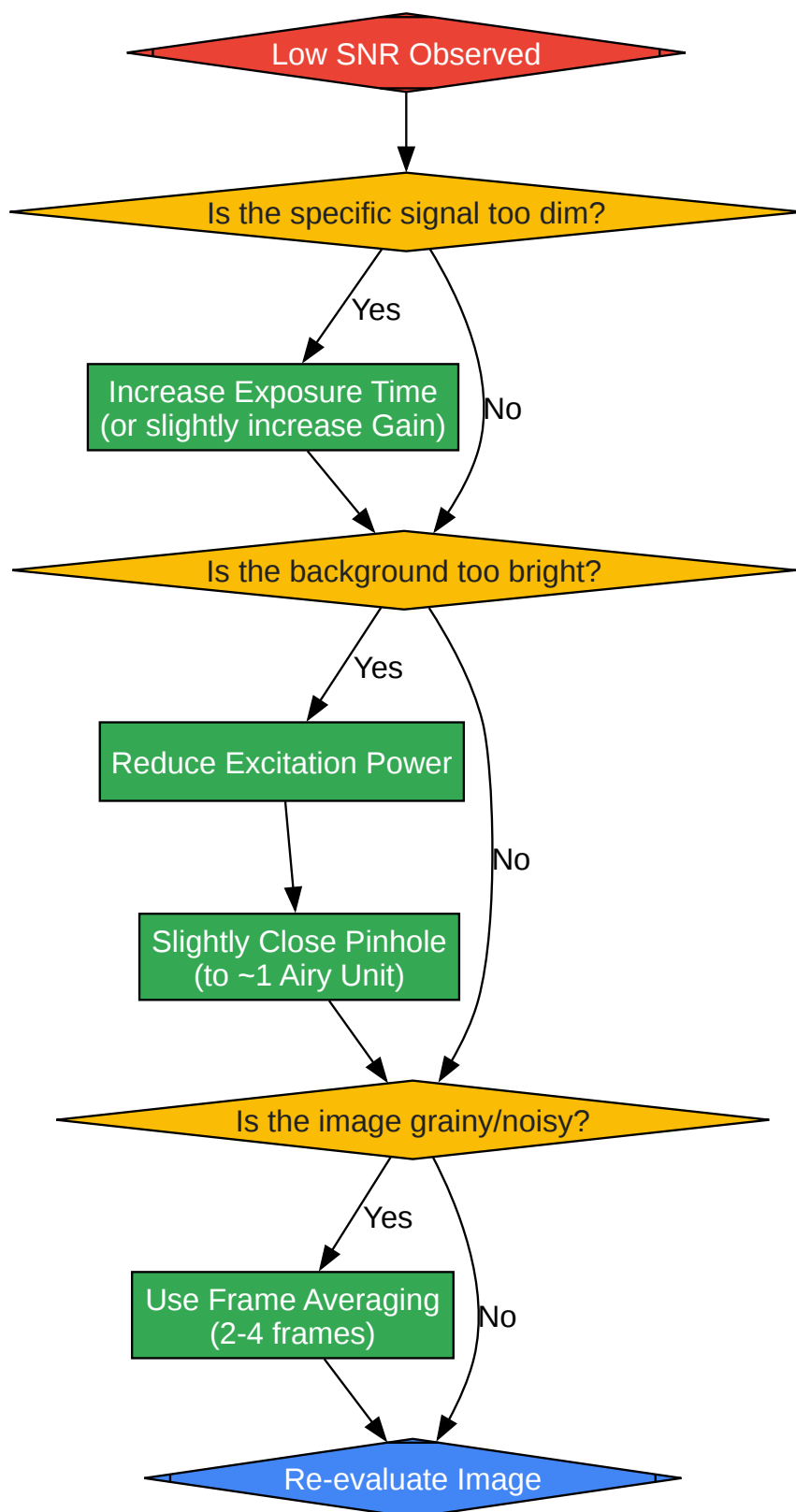

[Click to download full resolution via product page](#)

Caption: A decision tree for optimizing microscope settings.

## References

- A framework to enhance the signal-to-noise ratio for quantitative fluorescence microscopy. PLoS One. Available at: [\[Link\]](#)
- Top 10 Microscopy Troubleshooting Tips for Clearer Fluorescence Images. Keyence. Available at: [\[Link\]](#)
- A framework to enhance the signal-to-noise ratio for quantitative fluorescence microscopy. PLoS One. Available at: [\[Link\]](#)
- Background rejection and signal-to-noise optimization in confocal and alternative fluorescence microscopes. Optica Publishing Group. Available at: [\[Link\]](#)
- Signal-to-Noise Considerations. Evident Scientific. Available at: [\[Link\]](#)
- Improving Live Cell Fluorescence Imaging. Cell Culture Dish. Available at: [\[Link\]](#)
- How Can You Optimize Fluorescence Imaging for Clear and Accurate Results?. Evident Scientific. Available at: [\[Link\]](#)
- Fluorescent microscopy troubleshooting: high background. YouTube. Available at: [\[Link\]](#)
- Sources of autofluorescence in mammalian cells. ResearchGate. Available at: [\[Link\]](#)
- What is Autofluorescence? A Quick Explainer for Biologists. Bitesize Bio. Available at: [\[Link\]](#)
- Fluorescence Microscopy—An Outline of Hardware, Biological Handling, and Fluorophore Considerations. MDPI. Available at: [\[Link\]](#)
- Causes of Autofluorescence. Visikol. Available at: [\[Link\]](#)
- 9 tips to optimize your immunofluorescence staining. ONI. Available at: [\[Link\]](#)
- Live Cell Imaging. UConn Health. Available at: [\[Link\]](#)
- phenol red - Cellculture2. Altevista. Available at: [\[Link\]](#)
- Effect of laboratory lights on cell culture media. Cytiva. Available at: [\[Link\]](#)

- Fluorescent Quinolinium Derivative as Novel Mitochondria Probe and Function Modulator by Targeting Mitochondrial RNA. MDPI. Available at: [\[Link\]](#)
- Optimization Method of PBMC Staining and Visualization Using Fluorescence Microscopy. Oxford Academic. Available at: [\[Link\]](#)
- Quinolinium-Based Fluorescent Probes for Dynamic pH Monitoring in Aqueous Media at High pH Using Fluorescence Lifetime Imaging. PMC. Available at: [\[Link\]](#)
- How do I reduce high background in my FISH assay?. Oxford Gene Technology. Available at: [\[Link\]](#)
- Small quinolinium-based enzymatic probes via blue-to-red ratiometric fluorescence. PubMed. Available at: [\[Link\]](#)
- How to reduce autofluorescence in cell-based assays. BMG Labtech. Available at: [\[Link\]](#)
- Quinolinium-Based Fluorescent Probes for Dynamic pH Monitoring in Aqueous Media at High pH Using Fluorescence Lifetime Imaging. ResearchGate. Available at: [\[Link\]](#)
- Quinoline-Based Two-Photon Fluorescent Probe for Nitric Oxide in Live Cells and Tissues. ACS Publications. Available at: [\[Link\]](#)
- Impact of phenol red in cell culture and solutions. PromoCell. Available at: [\[Link\]](#)
- "Turn-On" Quinoline-Based Fluorescent Probe for Selective Imaging of Tau Aggregates in Alzheimer's Disease: Rational Design, Synthesis, and Molecular Docking. PubMed. Available at: [\[Link\]](#)
- Phenol red. Wikipedia. Available at: [\[Link\]](#)
- Tips to Minimize Autofluorescence. FluoroFinder. Available at: [\[Link\]](#)
- Elimination of autofluorescence background from fluorescence tissue images by use of time-gated detection and the AzaDiOxaTriAngulenium (ADOTA) fluorophore. PMC. Available at: [\[Link\]](#)

### Need Custom Synthesis?

BenchChem offers custom synthesis for rare earth carbides and specific isotopic labeling.

Email: [info@benchchem.com](mailto:info@benchchem.com) or [Request Quote Online](#).

## Sources

- [1. mdpi.com \[mdpi.com\]](https://www.mdpi.com)
- [2. Quinolinium-Based Fluorescent Probes for Dynamic pH Monitoring in Aqueous Media at High pH Using Fluorescence Lifetime Imaging - PMC \[pmc.ncbi.nlm.nih.gov\]](https://pubmed.ncbi.nlm.nih.gov/31111111/)
- [3. researchgate.net \[researchgate.net\]](https://www.researchgate.net)
- [4. Autofluorescence \[jacksonimmuno.com\]](https://www.jacksonimmuno.com)
- [5. Learn how to Remove Autofluorescence from your Confocal Images | Learn & Share | Leica Microsystems \[leica-microsystems.com\]](https://www.leica-microsystems.com/learn-and-share/learn-how-to-remove-autofluorescence-from-your-confocal-images)
- [6. bitesizebio.com \[bitesizebio.com\]](https://www.bitesizebio.com)
- [7. biotium.com \[biotium.com\]](https://www.biotium.com)
- [8. Tips to Minimize Autofluorescence - FluoroFinder \[fluorofinder.com\]](https://www.fluorofinder.com)
- [9. cellculturedish.com \[cellculturedish.com\]](https://www.cellculturedish.com)
- [10. phenol red - Cellculture2 \[cellculture2.altervista.org\]](https://www.cellculture2.com)
- [11. promocell.com \[promocell.com\]](https://www.promocell.com)
- [12. bmglabtech.com \[bmglabtech.com\]](https://www.bmglabtech.com)
- [13. Background in Fluorescence Imaging | Thermo Fisher Scientific - US \[thermofisher.com\]](https://www.thermofisher.com)
- [14. pdf.benchchem.com \[pdf.benchchem.com\]](https://pdf.benchchem.com)
- [15. Top 10 Microscopy Troubleshooting Tips for Clearer Fluorescence Images | KEYENCE America \[keyence.com\]](https://www.keyence.com)
- [16. youtube.com \[youtube.com\]](https://www.youtube.com)
- [17. A framework to enhance the signal-to-noise ratio for quantitative fluorescence microscopy | PLOS One \[journals.plos.org\]](https://journals.plos.org/plosone/article?id=10.1371/journal.plosone.0171111)
- [18. A framework to enhance the signal-to-noise ratio for quantitative fluorescence microscopy - PubMed \[pubmed.ncbi.nlm.nih.gov\]](https://pubmed.ncbi.nlm.nih.gov/26111111/)
- [19. Phenol red - Wikipedia \[en.wikipedia.org\]](https://en.wikipedia.org/wiki/Phenol_red)

- [20. cdn.cytivalifesciences.com \[cdn.cytivalifesciences.com\]](https://cdn.cytivalifesciences.com)
- [21. Live Cell Imaging | Richard D. Berlin Center for Cell Analysis & Modeling \[health.uconn.edu\]](https://health.uconn.edu)
- [22. researchgate.net \[researchgate.net\]](https://researchgate.net)
- [23. Causes of Autofluorescence \[visikol.com\]](https://visikol.com)
- [24. Elimination of autofluorescence background from fluorescence tissue images by use of time-gated detection and the AzaDiOxaTriAngulenium \(ADOTA\) fluorophore - PMC \[pmc.ncbi.nlm.nih.gov\]](https://pmc.ncbi.nlm.nih.gov)
- [25. oni.bio \[oni.bio\]](https://oni.bio)
- [26. biotium.com \[biotium.com\]](https://biotium.com)
- [27. OPG \[opg.optica.org\]](https://opg.optica.org)
- [28. precipoint.com \[precipoint.com\]](https://precipoint.com)
- [29. Signal-to-Noise Considerations \[evidentscientific.com\]](https://evidentscientific.com)
- To cite this document: BenchChem. [Minimizing background fluorescence in experiments with quinolinium probes]. BenchChem, [2026]. [Online PDF]. Available at: [\[https://www.benchchem.com/product/b372588/docs#minimizing-background-fluorescence-in-experiments-with-quinolinium-probes\]](https://www.benchchem.com/product/b372588/docs#minimizing-background-fluorescence-in-experiments-with-quinolinium-probes)

---

### Disclaimer & Data Validity:

The information provided in this document is for Research Use Only (RUO) and is strictly not intended for diagnostic or therapeutic procedures. While BenchChem strives to provide accurate protocols, we make no warranties, express or implied, regarding the fitness of this product for every specific experimental setup.

**Technical Support:** The protocols provided are for reference purposes. Unsure if this reagent suits your experiment?

**Need Industrial/Bulk Grade?** [Request Custom Synthesis Quote](#)

# BenchChem

Our mission is to be the trusted global source of essential and advanced chemicals, empowering scientists and researchers to drive progress in science and industry.

## Contact

Address: 3281 E Guasti Rd

Ontario, CA 91761, United States

Phone: (601) 213-4426

Email: [info@benchchem.com](mailto:info@benchchem.com)

[Contact our Ph.D. Support Team for a compatibility check](#)