

Technical Guide: Spectroscopic Profiling of 4-(N-Boc-N-methylamino)cyclohexanol

Author: BenchChem Technical Support Team. **Date:** May 2026

Compound of Interest

Compound Name:	4-(N-Boc-N-methylamino)cyclohexanol
CAS No.:	1256633-24-5
Cat. No.:	B036276

[Get Quote](#)

Executive Summary

4-(N-Boc-N-methylamino)cyclohexanol (CAS: 1256633-24-5) is a high-value bifunctional scaffold in medicinal chemistry.^[1] It serves as a critical linker in the synthesis of kinase inhibitors (e.g., JAK, EGFR) and GPCR ligands. Its cyclohexane ring offers a rigid spacer that can orient pharmacophores in specific vectors, improving metabolic stability compared to flexible alkyl chains.

This guide provides a definitive reference for the spectroscopic identification, synthesis, and stereochemical validation of this molecule. A specific focus is placed on distinguishing the cis and trans diastereomers—a frequent pain point in scale-up synthesis—and managing the rotameric complications observed in NMR spectroscopy due to the N-Boc-N-methyl functionality.

Structural Analysis & Stereochemistry

Conformation and Isomerism

The molecule exists as two diastereomers based on the relative orientation of the hydroxyl (-OH) and amino (-NR₂) groups.^[1]

- **Trans-Isomer (Thermodynamic):** Both the bulky amino group and the hydroxyl group occupy equatorial positions in the lowest-energy chair conformation.^[1] This is the most common target for drug discovery scaffolds.
- **Cis-Isomer (Kinetic):** One substituent is axial and the other is equatorial.^[1]

The Rotamer Challenge

Expert Insight: Unlike simple primary carbamates, the N-methyl-N-Boc moiety exhibits restricted rotation around the amide bond (

) at room temperature.^[1] This results in rotamers visible in NMR spectra (often a 60:40 or 70:30 split in CDCl₃

).

- **Symptom:** Broadening of signals or distinct doubling of the N-methyl and t-butyl peaks.^[1]
- **Solution:** Variable Temperature (VT) NMR at 50°C+ will coalesce these peaks, simplifying integration.

Spectroscopic Atlas

Mass Spectrometry (ESI-MS)

- Molecular Formula: C

H

NO

^[2]^[3]

- Exact Mass: 229.17 g/mol

Ion Type	m/z Value	Interpretation
[M+H]	230.2	Protonated molecular ion.[1]
[M+Na]	252.2	Sodium adduct (common in ESI).[1]
[M - tBu + 2H]	174.1	Loss of tert-butyl group (isobutylene).[1]
[M - Boc + 2H]	130.1	Complete loss of Boc group (N-methylaminocyclohexanol core).[1]

Nuclear Magnetic Resonance (NMR)

Solvent: CDCl₃

(referenced to 7.26 ppm for

H, 77.16 ppm for

C).[4]

H NMR Data (400 MHz)

Note: Data below describes the Trans-isomer (major rotamer reported).

Shift (ppm)	Multiplicity	Integration	Assignment	Structural Context
3.85 – 4.05	Multiplet (br)	1H	H-4	Methine adjacent to N. Deshielded by N-Boc/Me.[1]
3.55 – 3.65	tt (J ~ 11, 4 Hz)	1H	H-1	Methine adjacent to OH.[1] Large J indicates axial orientation (trans).
2.72 / 2.78	Singlet (split)	3H	N-CH	N-Methyl group. [1] Shows rotameric splitting.
1.95 – 2.05	Multiplet	2H	Ring H	Equatorial protons (positions 2,6 or 3,5).
1.80 – 1.90	Multiplet	2H	Ring H	Equatorial protons.[1]
1.46	Singlet	9H	Boc	tert-Butyl group. [1][5]
1.20 – 1.40	Multiplet	4H	Ring H	Axial protons (shielded).[1]

C NMR Data (100 MHz)

Shift (ppm)	Assignment	Notes
155.8	C=O	Carbamate carbonyl.[1]
79.5	C-O (t-Bu)	Quaternary carbon of Boc group.[1]
70.2	C-1 (CH-OH)	Carbinol carbon.[1]
52.4	C-4 (CH-N)	Methine attached to Nitrogen. [1]
29.0	N-CH	Methyl on Nitrogen (rotamers may appear).[1]
28.4	Boc-CH	Methyls of t-Butyl group (intense signal).[1]
33.5 / 28.0	Ring CH	Cyclohexane methylenes.[1]

Infrared Spectroscopy (FT-IR)

- 3400–3300 cm
: O-H stretch (broad, H-bonded).[1]
- 1680–1660 cm
: C=O stretch (Carbamate, strong).
- 1150–1100 cm
: C-O stretch (Alcohol/Ether).

Experimental Protocols

Synthesis Workflow (Reductive Amination)

The most robust route to the trans-isomer involves the reduction of the corresponding ketone.

Reagents:

- Starting Material: 4-(N-Boc-N-methylamino)cyclohexanone.[1]
- Reducing Agent: Sodium Borohydride (NaBH₄) or L-Selectride (for stereocontrol).[1]
- Solvent: Methanol (MeOH) or THF.

Protocol:

- Dissolve 4-(N-Boc-N-methylamino)cyclohexanone (1.0 eq) in dry MeOH at 0°C.
- Add NaBH₄ (1.5 eq) portion-wise over 30 minutes. (Caution: Gas evolution).
- Stir at 0°C for 1 hour, then warm to Room Temperature (RT) for 2 hours.
- Quench: Add saturated NH₄Cl solution.
- Extraction: Extract with Ethyl Acetate (3x). Wash organics with brine, dry over Na₂SO₄.
- Purification: The crude product is often a mixture of cis and trans (approx 3:7 to 4:6).
 - Separation: Flash Column Chromatography (Hexane:EtOAc gradient). The trans-isomer is typically more polar (elutes later) due to the equatorial OH being more accessible for interaction with silica.[1]

Visual Workflow (Graphviz)



[Click to download full resolution via product page](#)

Caption: Step-by-step synthesis and purification workflow for isolating the trans-isomer.

Quality Control & Validation Logic

Distinguishing the cis and trans isomers is the critical QC step. Do not rely solely on retention time; use NMR coupling constants (

-values).[1]

The J-Value Rule (Self-Validating Protocol)

- Trans-Isomer (Diequatorial): The proton at C-1 (H-1) is Axial.[1] It couples with the adjacent axial protons (at C-2/C-6) with a large coupling constant (

Hz).[1]

- Appearance: H-1 appears as a wide triplet of triplets (tt) or broad multiplet with width at half-height (

) > 20 Hz.[1]

- Cis-Isomer (Axial-Equatorial): The proton at C-1 (H-1) is Equatorial (assuming the bulky amine anchors the ring).[1] It couples with adjacent protons with small constants (

Hz).[1]

- Appearance: H-1 appears as a narrow multiplet or broad singlet with

< 12 Hz.[1]

Decision Tree for Isomer Identification

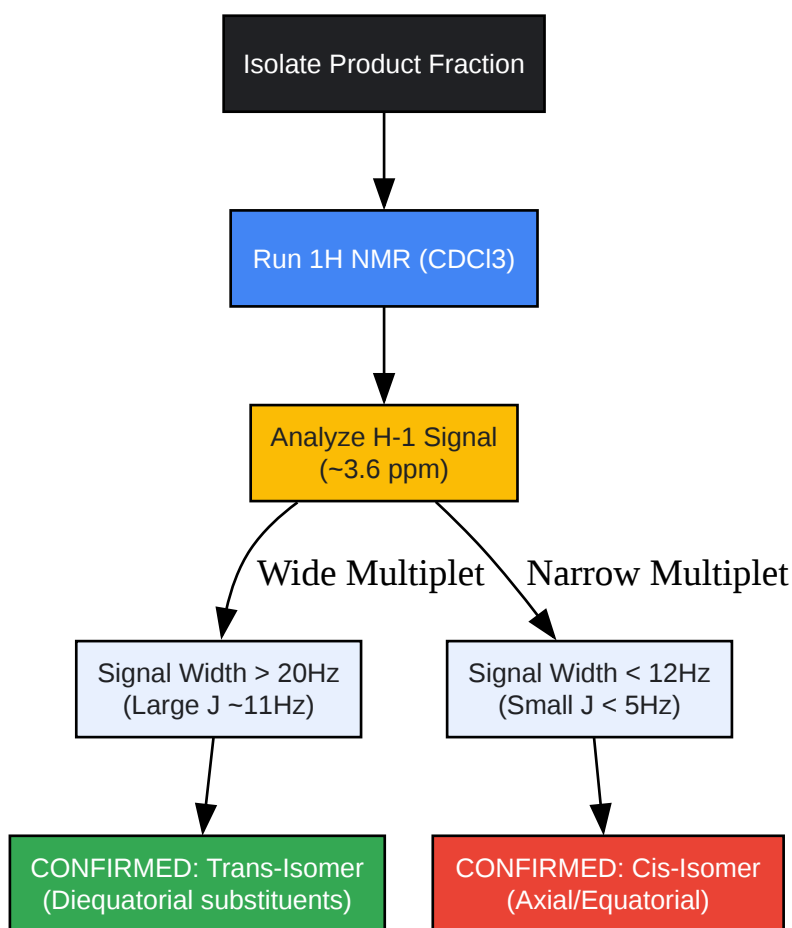

[Click to download full resolution via product page](#)

Caption: Logic tree for distinguishing Cis/Trans isomers using 1H NMR coupling constants.

References

- National Center for Biotechnology Information. PubChem Compound Summary for CID 21925147, **4-(N-Boc-N-methylamino)cyclohexanol**. [1] PubChem. [3][5][6][7][8] [Link]
- Organic Chemistry Portal. Reductive Amination: Synthesis of Amines. (General protocols for ketone to amine conversion). [Link]
- Reich, H. J. WinPLT NMR Data: Cyclohexane Derivatives. University of Wisconsin-Madison. [1] (Reference for axial/equatorial chemical shift rules). [Link]

Need Custom Synthesis?

BenchChem offers custom synthesis for rare earth carbides and specific isotopic labeling.

Email: info@benchchem.com or [Request Quote Online](#).

Sources

- 1. [167081-25-6 | MFCD03844614 | tert-butyl \(cis-4-hydroxycyclohexyl\)carbamate \[aaronchem.com\]](#)
- 2. [1188475-96-8|tert-Butyl \(\(4-hydroxycyclohexyl\)methyl\)carbamate|BLD Pharm \[bldpharm.com\]](#)
- 3. [tert-Butyl \(4-hydroxy-1-methylcyclohexyl\)carbamate | C12H23NO3 | CID 45098094 - PubChem \[pubchem.ncbi.nlm.nih.gov\]](#)
- 4. [rsc.org \[rsc.org\]](#)
- 5. [tert-butyl N-\(4-oxocyclohexyl\)carbamate | C11H19NO3 | CID 1512535 - PubChem \[pubchem.ncbi.nlm.nih.gov\]](#)
- 6. [4-Methylcyclohexanol | C7H14O | CID 11524 - PubChem \[pubchem.ncbi.nlm.nih.gov\]](#)
- 7. [4-Aminocyclohexanol | C6H13NO | CID 81293 - PubChem \[pubchem.ncbi.nlm.nih.gov\]](#)
- 8. [tert-butyl N-\[\(4-formylcyclohexyl\)methyl\]carbamate | C13H23NO3 | CID 15408001 - PubChem \[pubchem.ncbi.nlm.nih.gov\]](#)
- To cite this document: BenchChem. [Technical Guide: Spectroscopic Profiling of 4-(N-Boc-N-methylamino)cyclohexanol]. BenchChem, [2026]. [Online PDF]. Available at: [\[https://www.benchchem.com/product/b036276/docs#technical-guide-spectroscopic-profiling-of-4-n-boc-n-methylamino-cyclohexanol\]](https://www.benchchem.com/product/b036276/docs#technical-guide-spectroscopic-profiling-of-4-n-boc-n-methylamino-cyclohexanol)

Disclaimer & Data Validity:

The information provided in this document is for Research Use Only (RUO) and is strictly not intended for diagnostic or therapeutic procedures. While BenchChem strives to provide accurate protocols, we make no warranties, express or implied, regarding the fitness of this product for every specific experimental setup.

Technical Support: The protocols provided are for reference purposes. Unsure if this reagent suits your experiment?

Need Industrial/Bulk Grade? [Request Custom Synthesis Quote](#)

BenchChem

Our mission is to be the trusted global source of essential and advanced chemicals, empowering scientists and researchers to drive progress in science and industry.

Contact

Address: 3281 E Guasti Rd
Ontario, CA 91761, United States
Phone: (601) 213-4426
Email: info@benchchem.com

[Contact our Ph.D. Support Team for a compatibility check](#)