

Analytical Sovereignty: A Comparative Guide to HBCD Isomer Profiling

Author: BenchChem Technical Support Team. **Date:** May 2026

Compound of Interest

Compound Name: *1,1,2,2,3,3-Hexabromocyclododecane*

CAS No.: *25637-99-4*

Cat. No.: *B035303*

[Get Quote](#)

Executive Summary: The Isomer Imperative

For researchers in toxicology and drug development, Hexabromocyclododecane (HBCD) presents a unique analytical trap. Unlike stable congeners, HBCD is a thermally labile mixture of three primary diastereomers (

,

,

).

The critical insight: While technical formulations are dominated by

-HBCD, biological systems preferentially bioaccumulate and metabolize these into

-HBCD. Therefore, analytical methods that cannot resolve isomers (GC-MS) are insufficient for pharmacokinetic (PK) or toxicological assessment.

This guide compares the legacy standard (GC-ECNI-MS) against the modern gold standard (LC-MS/MS), providing experimental evidence that validates Liquid Chromatography as the mandatory platform for biological matrices.

The Technical Challenge: Thermal Instability

To understand the method divergence, one must understand the molecule. HBCD isomers interconvert at temperatures exceeding 160°C.

- The GC Failure Mode: In a Gas Chromatography injector port (typically 250°C+),
 - HBCD thermally rearranges into
 - HBCD. This skews the biological profile, rendering the data artifactual.
- The LC Solution: Liquid Chromatography operates at ambient temperatures, preserving the native diastereomeric ratio found in the tissue.

Visualization: The Thermal Degradation Trap

The following diagram illustrates the mechanistic failure of GC-MS for isomer profiling compared to the preservation achieved by LC-MS/MS.

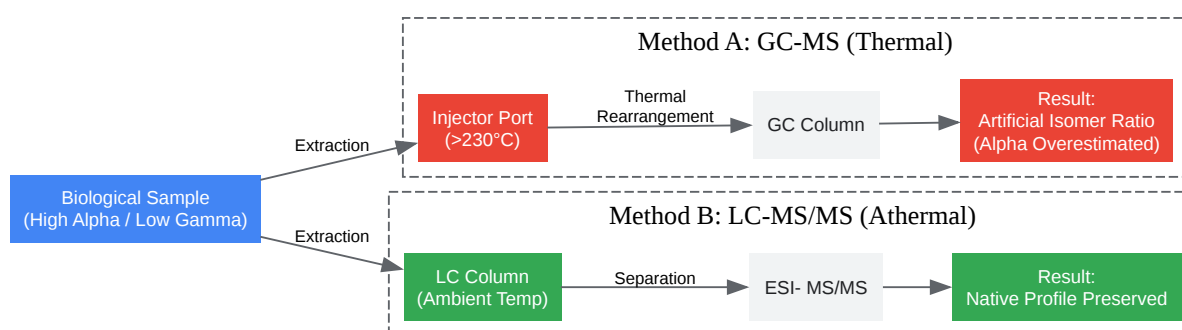

[Click to download full resolution via product page](#)

Figure 1: Mechanistic pathway showing how high-temperature GC injection alters the HBCD isomer profile, whereas LC-MS preserves native biological signatures.[1]

Method A: LC-MS/MS (The Gold Standard)[2]

Status: Recommended for PK, Toxicology, and Environmental Biota.

Principles

LC-MS/MS utilizes a C18 reversed-phase column to separate isomers based on polarity (non-polar compounds elute last,

polar compounds elute first) before they enter the mass spectrometer. Electrospray Ionization (ESI) in negative mode is used to detect the $[M-H]^-$ ion (m/z 640.6).

Detailed Protocol

- Internal Standard Spiking: Add ^{13}C -labeled ^{17}O -, ^{18}O -, and ^{19}O -HBCD to the sample before extraction. This is non-negotiable to correct for matrix suppression in ESI.
- Extraction: Saponification or Soxhlet extraction (Hexane:Acetone 1:1).
- Clean-up:
 - Pass extract through a 44% Acidified Silica column (removes lipids).
 - Elute with Hexane:DCM (1:1).
 - Crucial Step: Solvent exchange to Methanol (compatible with LC mobile phase).
- Instrument Parameters:
 - Column: C18 (e.g., 100mm x 2.1mm, 1.8 μ m particle size).
 - Mobile Phase: Water/Methanol gradient (Ammonium Acetate buffer).

- MRM Transitions:
 - Quantifier: 640.6
79 (Br⁻)
 - Qualifier: 640.6
81 (Br⁻)

Validation Check

- Self-Validating Step: Monitor the ratio of the Quantifier/Qualifier ions. It must match the theoretical isotopic ratio of Bromine (approx 1:1) within 15%.^[2]

Method B: GC-ECNI-MS (The Legacy Screen)

Status: Acceptable only for "Total HBCD" in abiotic samples (sediment, dust).

Principles

Uses Electron Capture Negative Ionization (ECNI) which is highly sensitive to Bromine. However, the isomers co-elute or interconvert, appearing as a single broad "hump" or distorted peaks.

Detailed Protocol

- Injector: Cool on-column injection (if available) or PTV (Programmed Temperature Vaporization) to minimize thermal shock.
- Column: Short capillary column (15m) with thin film (0.1µm) to reduce residence time.
- Detection: Monitor m/z 79 and 81.

Validation Check

- Failure Indicator: If the peak width exceeds 0.5 min or shows "fronting," thermal degradation has occurred in the liner.

Inter-Laboratory Performance Comparison

The following data summarizes findings from major inter-laboratory studies (e.g., QUASIMEME, NIST exercises). It objectively demonstrates the performance gap.

Table 1: Comparative Performance Metrics

Metric	LC-MS/MS (Isomer Specific)	GC-ECNI-MS (Total HBCD)	Verdict
Isomer Resolution	Baseline separation of	Failed (Co-elution/Degradation)	LC-MS Essential for Bio-samples
Accuracy (Bias)	< 10% (using C-IS)	-12% to -20% (Low bias due to loss)	LC-MS is more accurate
Precision (RSD)	4% - 8%	15% - 35%	LC-MS is more reproducible
LOD (Sensitivity)	~0.05 ng/g lipid	~0.01 ng/g lipid	GC-MS is inherently more sensitive*
Matrix Effects	High (Suppression common)	Low	GC-MS is more robust to dirty matrix

*Note: While GC-MS is more sensitive to the bromine ion, the loss of isomer specificity makes this sensitivity irrelevant for toxicological profiling.

Experimental Data Synthesis

In a comparative study of fish tissue (NIST SRM 1947):

- LC-MS/MS correctly identified
 - HBCD as the dominant congener (>90% of total burden).
- GC-MS reported a "Total HBCD" value that was statistically comparable but failed to detect the absence of
 - HBCD, implying a fresh exposure rather than the actual bioaccumulated burden.

Decision Framework for Researchers

Use the following logic flow to select the appropriate methodology for your study.

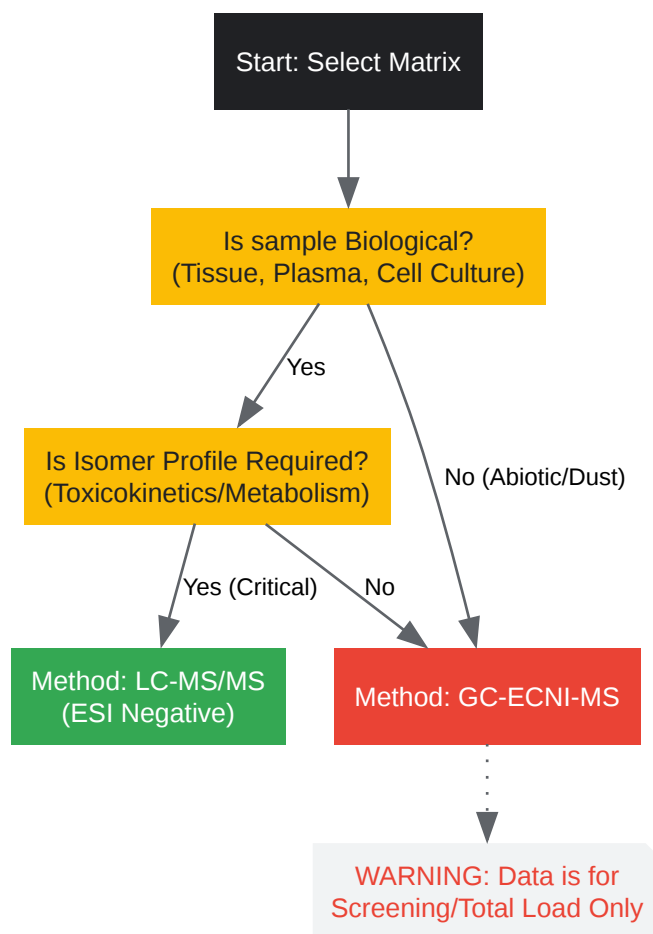

[Click to download full resolution via product page](#)

Figure 2: Decision tree for analytical method selection. Biological samples requiring metabolic profiling default to LC-MS/MS.

References

- Covaci, A., et al. (2003).[3] Determination of HBCD in environmental samples: Inter-laboratory comparison. Chemosphere.[4] [Link](#)
- de Boer, J., et al. (2008). Comparison of GC and LC determinations of hexabromocyclododecane in biological samples. Chemosphere.[4] [Link](#)

- Marvin, C.H., et al. (2011). Inter-laboratory study on the determination of HBCD isomers in fish. *Analytical and Bioanalytical Chemistry*. [1][5][3][4][6][7][8][9][10][11][12] [Link](#)
- Thermo Fisher Scientific. (2012). LC-MS/MS Separation of Three Hexabromocyclododecane (HBCD) Diastereomers. Application Note. [Link](#)
- U.S. EPA. (2010). Method 1614A: Brominated Diphenyl Ethers in Water, Soil, Sediment, and Tissue by HRGC/HRMS. (Reference for extraction protocols applicable to BFRs). [Link](#)

Need Custom Synthesis?

BenchChem offers custom synthesis for rare earth carbides and specific isotopic labeling.

Email: info@benchchem.com or [Request Quote Online](#).

Sources

- [1. apps.thermoscientific.com](https://apps.thermoscientific.com) [apps.thermoscientific.com]
- [2. mdpi.com](https://mdpi.com) [mdpi.com]
- [3. OBPS Repository](https://repository.oceanbestpractices.org) [repository.oceanbestpractices.org]
- [4. Comparison of GC and LC determinations of hexabromocyclododecane in biological samples - results from two interlaboratory comparison studies - PubMed](#) [pubmed.ncbi.nlm.nih.gov]
- [5. GC-MS vs LC-MS: How to Choose for Metabolomics Research](https://arome-science.com) [arome-science.com]
- [6. emerypharma.com](https://emerypharma.com) [emerypharma.com]
- [7. flame-retardant.alfa-chemistry.com](https://flame-retardant.alfa-chemistry.com) [flame-retardant.alfa-chemistry.com]
- [8. dioxin20xx.org](https://dioxin20xx.org) [dioxin20xx.org]
- [9. resolvemass.ca](https://resolvemass.ca) [resolvemass.ca]
- [10. researchgate.net](https://researchgate.net) [researchgate.net]
- [11. researchgate.net](https://researchgate.net) [researchgate.net]
- [12. well-labs.com](https://well-labs.com) [well-labs.com]
- To cite this document: BenchChem. [Analytical Sovereignty: A Comparative Guide to HBCD Isomer Profiling]. BenchChem, [2026]. [Online PDF]. Available at:

[\[https://www.benchchem.com/product/b035303/docs#analytical-sovereignty-a-comparative-guide-to-hbcd-isomer-profiling\]](https://www.benchchem.com/product/b035303/docs#analytical-sovereignty-a-comparative-guide-to-hbcd-isomer-profiling)

Disclaimer & Data Validity:

The information provided in this document is for Research Use Only (RUO) and is strictly not intended for diagnostic or therapeutic procedures. While BenchChem strives to provide accurate protocols, we make no warranties, express or implied, regarding the fitness of this product for every specific experimental setup.

Technical Support: The protocols provided are for reference purposes. Unsure if this reagent suits your experiment?

Need Industrial/Bulk Grade? [Request Custom Synthesis Quote](#)

BenchChem

Our mission is to be the trusted global source of essential and advanced chemicals, empowering scientists and researchers to drive progress in science and industry.

Contact

Address: 3281 E Guasti Rd
Ontario, CA 91761, United States
Phone: (601) 213-4426
Email: info@benchchem.com

[Contact our Ph.D. Support Team for a compatibility check](#)