

# Technical Guide: Identification of 3',4',7-Trimethoxyflavanone in Herbal Extracts

**Author:** BenchChem Technical Support Team. **Date:** May 2026

## Compound of Interest

Compound Name: 3',4',7-Trimethoxyflavanone

Cat. No.: B349634

[Get Quote](#)

## Executive Summary & Chemical Profile

Target Analyte: **3',4',7-Trimethoxyflavanone** IUPAC Name: 7-methoxy-2-(3,4-dimethoxyphenyl)-2,3-dihydrochromen-4-one Molecular Formula: C<sub>18</sub>H<sub>18</sub>O<sub>5</sub> Molecular Weight: 314.33 g/mol Key Structural Feature: Saturated C2–C3 bond (flavanone core) distinguishing it from its flavone analog (3',4',7-Trimethoxyflavone).<sup>[1][2]</sup>

Significance: This compound is a lipophilic flavonoid often co-eluting with polymethoxylated flavones (PMFs). Its identification requires rigorous differentiation from its unsaturated counterpart and its 5-hydroxy derivatives (e.g., 5-hydroxy-**3',4',7-trimethoxyflavanone**).

## Extraction & Enrichment Strategy

Because **3',4',7-Trimethoxyflavanone** lacks free hydroxyl groups on the A-ring (unless it is the 5-OH derivative) and B-ring, it exhibits high lipophilicity. Standard aqueous-alcoholic extractions often yield high background noise from glycosides.

## Protocol: Targeted Lipophilic Extraction

- Matrix Preparation: Pulverize dried herbal material (e.g., Pogostemon cablin leaves) to <40 mesh.
- Primary Extraction: Macerate in 95% Ethanol or Methanol (1:10 w/v) for 24h. Sonication (UAE) at 40 kHz for 30 min improves yield.
- Liquid-Liquid Partitioning (Critical Step):
  - Evaporate ethanol to obtain a crude syrup.
  - Resuspend in H<sub>2</sub>O.
  - Partition sequentially with n-Hexane (removes waxes/lipids)  
  
Chloroform (CHCl<sub>3</sub>) or Dichloromethane (DCM).
  - Target Capture: The **3',4',7-Trimethoxyflavanone** will predominantly partition into the CHCl<sub>3</sub>/DCM layer due to its methoxylated (non-polar) nature. Discard the aqueous phase containing glycosides.

## High-Resolution Separation (UHPLC-PDA)

Separation must resolve the flavanone from its flavone analog. The flavanone elutes earlier than the corresponding flavone on C18 due to the non-planar flexibility of the saturated C-ring reducing hydrophobic interaction density.

## Chromatographic Conditions

Parameter	Setting	Rationale
Column	C18 (e.g., 2.1 x 100 mm, 1.7 $\mu$ m)	High surface area for resolving isomers.
Mobile Phase A	0.1% Formic Acid in Water	Protonation ensures sharp peaks for MS.
Mobile Phase B	Acetonitrile (ACN)	Methanol creates higher backpressure; ACN is preferred for lipophiles.
Gradient	30% B (0-2 min) 90% B (15 min)	Shallow gradient required to separate flavanone/flavone pairs.
Flow Rate	0.3 - 0.4 mL/min	Optimal for ESI ionization efficiency.
Detection	PDA (280 nm, 320 nm)	280 nm is specific for Flavanone Band II.

## Spectroscopic Identification (MS & NMR)[1][2][3][4][5]

### A. Mass Spectrometry (LC-ESI-MS/MS)

The fragmentation pattern is the primary tool for structural confirmation. Flavanones undergo a characteristic Retro-Diels-Alder (RDA) cleavage of the C-ring.

- Precursor Ion:  $[M+H]^+ = 315.12$
- Primary Fragmentation (RDA Cleavage):
  - RDA Mechanism: Cleavage of bonds 1–2 and 3–4.
  - Fragment A (A-Ring):  
  
ion at  $m/z$  151 (7-methoxy group intact).

- Fragment B (B-Ring):  
ion at  $m/z$  164 (3',4'-dimethoxy styrene moiety).
- Secondary Losses:
  - Loss of Methyl radical ( $\bullet\text{CH}_3$ , -15 Da)  
 $m/z$  300.
  - Loss of Carbonyl (CO, -28 Da).

## B. Nuclear Magnetic Resonance (NMR) - The "Gold Standard"

NMR is required to definitively prove the saturation of the C-ring (distinguishing flavanone from flavone).

Key  $^1\text{H}$ -NMR Signals ( $\text{CDCl}_3$ , 500 MHz):

- The Flavanone "Signature" (C-Ring):
  - H-2: dd at  $\delta$  5.30–5.45 (1H).
  - H-3ax: dd at  $\delta$  3.00–3.15 (1H, large coupling constant  $J \sim 17\text{Hz}$ , 13Hz).
  - H-3eq: dd at  $\delta$  2.75–2.85 (1H,  $J \sim 17\text{Hz}$ , 3Hz).
  - Note: If this were a flavone, these three signals would be replaced by a single singlet at  $\delta \sim 6.6$  (H-3).
- A-Ring (7-OMe):
  - H-5: d ( $J \sim 8.8$  Hz) at  $\delta \sim 7.8$  (Deshielded by carbonyl).
  - H-6: dd at  $\delta \sim 6.6$ .
  - H-8: d ( $J \sim 2.5$  Hz) at  $\delta \sim 6.5$ .

- 7-OMe: Singlet at  $\delta$  3.8–3.9.
- B-Ring (3',4'-diOMe):
  - ABX system signals at  $\delta$  6.9–7.1.
  - Two methoxy singlets at  $\delta$  3.8–3.9.

## Visualization of Workflows

### Diagram 1: Analytical Decision Tree

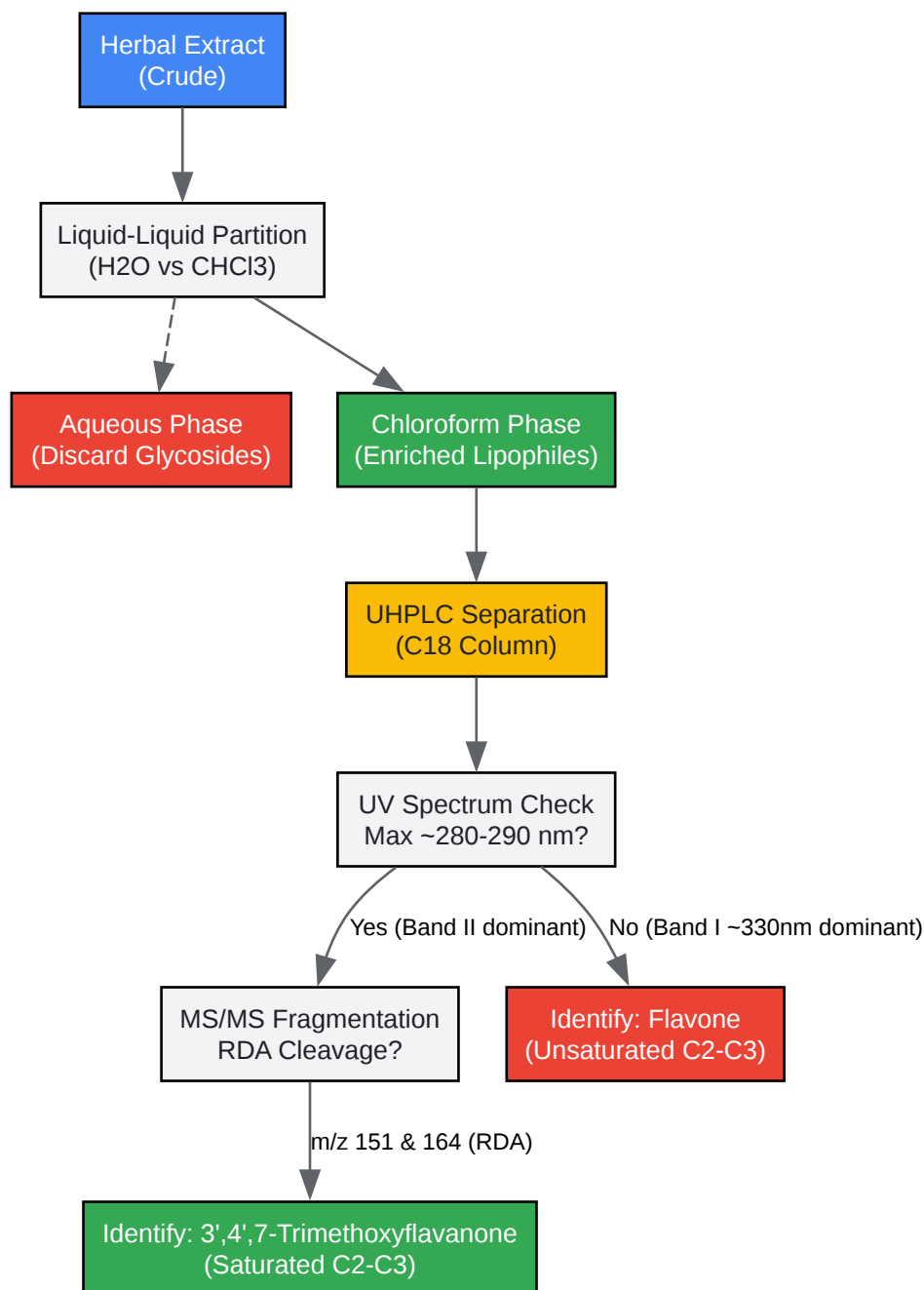

[Click to download full resolution via product page](#)

Caption: Decision tree for isolating and differentiating trimethoxyflavanone from flavone analogs.

## Diagram 2: MS Fragmentation Pathway (RDA)

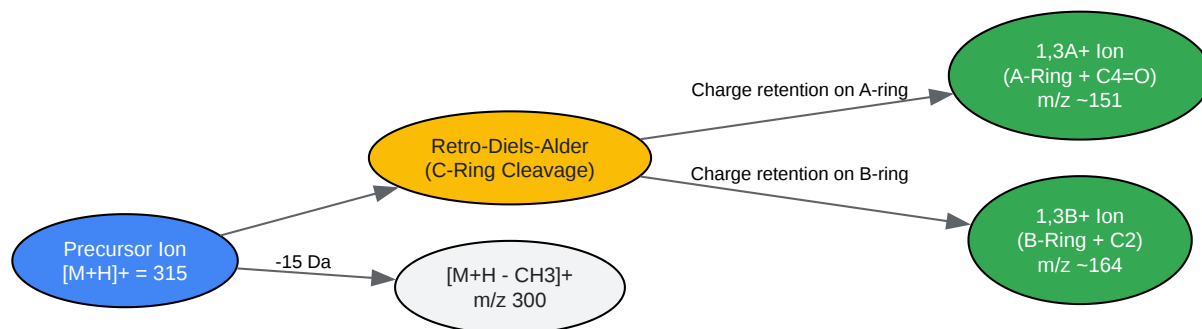

[Click to download full resolution via product page](#)

Caption: Retro-Diels-Alder (RDA) fragmentation mechanism characteristic of flavanones.

## Validation Parameters

To ensure data integrity (Trustworthiness), the method must be validated:

- Linearity:  $R^2 > 0.999$  over 0.5 – 50  $\mu\text{g/mL}$  range.
- LOD/LOQ: Typically ~10 ng/mL (LOD) and ~30 ng/mL (LOQ) using MRM mode.
- Precision: Intra-day RSD < 2.0%.[\[3\]](#)

## References

- Hu, L., et al. (2006). Isolation and identification of flavonoids from *Pogostemon cablin*. *Journal of Chinese Medicinal Materials*. [Link](#)
- Zhang, X., et al. (2019). Chemical constituents from the leaves of *Sapium sebiferum*. *Chemistry of Natural Compounds*. [Link](#)
- BenchChem. (2025). Technical Guide: Natural Plant Sources of 3,4'-Dihydroxyflavone and Related Methoxyflavones. [Link](#)
- MetwareBio. (2024). Ion Formation and Organic Fragmentation in LCMS: Unlocking the Secrets of Mass Spectra. [Link](#)

- Mabry, T. J., et al. (1970). The Systematic Identification of Flavonoids. Springer-Verlag. (Seminal text on UV/NMR shifts).

#### Need Custom Synthesis?

BenchChem offers custom synthesis for rare earth carbides and specific isotopic labeling.

Email: [info@benchchem.com](mailto:info@benchchem.com) or [Request Quote Online](#).

## Sources

- [1. researchgate.net \[researchgate.net\]](https://www.researchgate.net)
- [2. Soyacerebroside II | CAS:115074-93-6 | Manufacturer ChemFaces \[chemfaces.com\]](#)
- [3. researchgate.net \[researchgate.net\]](https://www.researchgate.net)
- To cite this document: BenchChem. [Technical Guide: Identification of 3',4',7-Trimethoxyflavanone in Herbal Extracts]. BenchChem, [2026]. [Online PDF]. Available at: [\[https://www.benchchem.com/product/b349634/docs#technical-guide-identification-of-3-4-7-trimethoxyflavanone-in-herbal-extracts\]](https://www.benchchem.com/product/b349634/docs#technical-guide-identification-of-3-4-7-trimethoxyflavanone-in-herbal-extracts)

---

### Disclaimer & Data Validity:

The information provided in this document is for Research Use Only (RUO) and is strictly not intended for diagnostic or therapeutic procedures. While BenchChem strives to provide accurate protocols, we make no warranties, express or implied, regarding the fitness of this product for every specific experimental setup.

**Technical Support:** The protocols provided are for reference purposes. Unsure if this reagent suits your experiment?

**Need Industrial/Bulk Grade?** [Request Custom Synthesis Quote](#)

# BenchChem

Our mission is to be the trusted global source of essential and advanced chemicals, empowering scientists and researchers to drive progress in science and industry.

## Contact

Address: 3281 E Guasti Rd

Ontario, CA 91761, United States

Phone: (601) 213-4426

Email: [info@benchchem.com](mailto:info@benchchem.com)

[Contact our Ph.D. Support Team for a compatibility check](#)