

# Advanced Characterization Guide: Mass Spectrometry of Phenoxyethyl Piperidines

**Author:** BenchChem Technical Support Team. **Date:** April 2026

## Compound of Interest

Compound Name: 1-[2-(4-methoxyphenoxy)ethyl]piperidine

Cat. No.: B3463095

[Get Quote](#)

## Executive Summary

In medicinal chemistry, the phenoxyethyl piperidine moiety acts as a critical pharmacophore in various neuroactive agents (e.g., sigma receptor ligands, acetylcholinesterase inhibitors).[1][2] Structurally, it combines a basic piperidine ring with a lipophilic phenoxy group via an ethyl ether linker.[1][2]

For drug development professionals, distinguishing this scaffold from structurally similar analogs—such as benzyl piperidines or phenethyl piperidines—is a frequent analytical challenge.[1][2] This guide provides a definitive technical comparison of the mass spectrometry (MS) behaviors of phenoxyethyl piperidines versus their hydrocarbon analogs.[1] We delineate the specific fragmentation mechanisms driven by the ether oxygen atom, providing a self-validating protocol for structural confirmation.[1]

## Mechanistic Overview: The "Oxygen Effect"[1]

The fragmentation of phenoxyethyl piperidines is governed by the competition between the nitrogen atom's ability to stabilize a positive charge and the lability of the C–O ether bond.[1]

## Electron Ionization (EI) Behavior

Under standard 70 eV EI conditions, the ionization typically occurs at the nitrogen lone pair due to its lower ionization potential compared to the ether oxygen or the aromatic ring.[1]

- **Primary Pathway (Alpha-Cleavage):** The radical cation undergoes homolytic cleavage at the C–C bond adjacent to the nitrogen. This generates the thermodynamically stable methylene-piperidinium ion (98), which is often the base peak.[1]
- **Secondary Pathway (Ether Cleavage):** Unlike alkyl analogs, the presence of the oxygen atom facilitates cleavage at the C–O bond, often yielding a phenoxy radical or phenol neutral loss, though the charge predominantly remains on the nitrogen-containing fragment.[1]
- **Diagnostic Aromatic Ions:** The phenoxy group contributes characteristic low-mass ions at 77 ( ) and 94 ( ), distinguishing it from non-oxygenated analogs.[1][2]

## Electrospray Ionization (ESI-CID) Behavior

In LC-MS/MS (positive mode), the molecule forms an abundant

precursor.[2] Upon Collision-Induced Dissociation (CID):

- **Neutral Loss of Phenol:** A characteristic pathway involves proton transfer to the ether oxygen followed by elimination of neutral phenol ( ), leaving an alkenyl-piperidine cation.[1]
- **Piperidine Ring Cleavage:** High collision energies may fragment the piperidine ring itself, producing ions at 84 or 55.[1][2]

## Comparative Analysis: Phenoxyethyl vs. Benzyl Piperidines[2]

The core analytical challenge lies in differentiating the Phenoxyethyl linker ( ) from the Benzyl linker ( ) or Phenethyl linker ( ).

### Performance Comparison Table

Feature	Phenoxyethyl Piperidines	Benzyl Piperidines (Alternative)	differentiation Logic
Base Peak (EI)	98 ( )	91 ( )	Benzyl cations (Tropylium) are more stable than piperidinium ions; Phenoxyethyl lacks this stable carbocation path.[2]
Molecular Ion ( )	Weak / Distinct	Moderate	Benzyl analogs often show stronger due to lack of labile ether bond.
Diagnostic Neutral Loss	Phenoxy ( ) or Phenol ( )	Benzyl radical ( )	The loss of 94 Da in ESI is a "smoking gun" for the phenoxy ether moiety.[1]
Low Mass Fingerprint	77, 94, 107	65, 91	Presence of 94 (phenol radical) confirms the ether linkage.[1][2]
Alpha-Cleavage Product	98 (Dominant)	174 (M-H) or 91	Benzyl piperidines cleave at the benzylic bond, favoring the aromatic fragment over the amine.[1]

## Visualizing the Fragmentation Pathways[1]

The following diagram contrasts the fragmentation logic. Note how the "Oxygen Switch" diverts the pathway away from the Tropylium ion formation seen in benzyl analogs.[1]

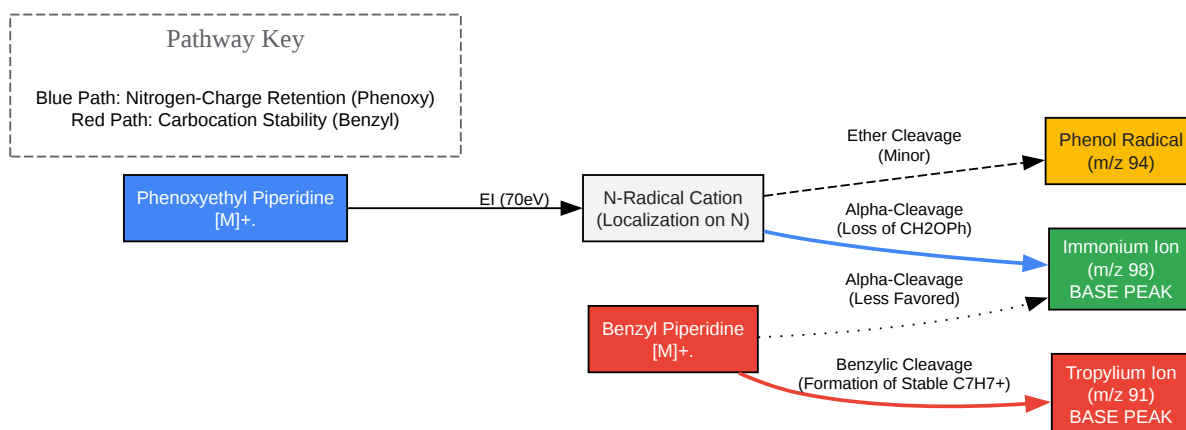

[Click to download full resolution via product page](#)

Figure 1: Comparative fragmentation logic. Phenoxyethyl derivatives favor nitrogen charge retention (

98), while benzyl derivatives favor aromatic charge retention (

91).[1][2]

## Experimental Protocols

To replicate these results and validate the structure of a candidate phenoxyethyl piperidine, follow this self-validating workflow.

### GC-MS Analysis (Structural Fingerprinting)

Objective: Confirm the presence of the piperidine ring (

98) and the phenoxy ether linkage (

94).

- Sample Prep: Dissolve

of compound in

Methanol (HPLC grade).

- Inlet: Splitless mode,  
.
- Column: DB-5ms or equivalent (  
,  
film).
- Oven Program:  
(1 min)  
(hold 3 min).
- MS Source: Electron Ionization (EI),  
,  
. [1][2]
- Scan Range:  
40–400.
- Validation Criteria:
  - Base Peak: Must be  
98 (or substituted equivalent).
  - Qualifiers: Presence of  
94 and  
77. Absence of dominant  
91 (rules out benzyl impurity).

## LC-ESI-MS/MS (High Sensitivity Detection)

Objective: Quantitation and confirmation via neutral loss scanning.

- Mobile Phase:
  - A:  
Formic Acid in Water.[2]
  - B:  
Formic Acid in Acetonitrile.[2]
- Gradient: 5% B to 95% B over 5 minutes.
- Ionization: ESI Positive Mode ( ).
- MS/MS Experiment:
  - Select precursor  
.[2][3]
  - Apply Collision Energy (CE) ramp:  
.
- Validation Criteria:
  - Observe transition  
.[2] This specific neutral loss of phenol is highly characteristic of the phenoxyethyl ether chain.[1]

## Workflow Diagram

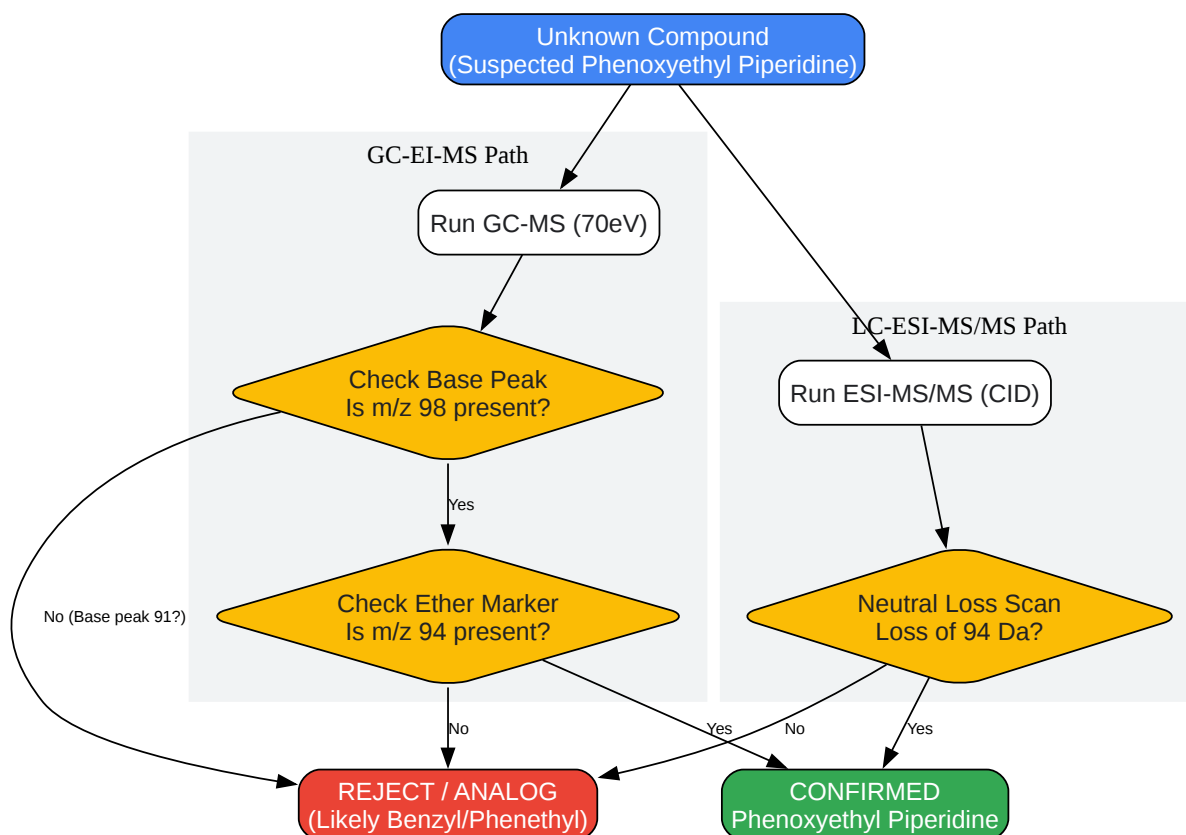

[Click to download full resolution via product page](#)

Figure 2: Decision tree for confirming phenoxyethyl piperidine structure using MS data.

## References

- National Institute of Standards and Technology (NIST). Mass Spectrum of Piperidine, 1-(2-phenylethyl)- (Phenethylpiperidine). [2] NIST Chemistry WebBook, SRD 69. [1][2][4][5] Accessed 2025. [2][3][6][7] [Link][1]

- Zhu, N., et al. Mass Fragmentation Characteristics of Piperazine Analogues (Comparison of Benzyl vs. Phenyl derivatives). Journal of Chinese Pharmaceutical Sciences, 2019.[1][2] (Analogous fragmentation mechanisms cited for benzyl/phenyl differentiation).[8] [\[Link\]](#)
- Michigan State University (Reusch, W.). Mass Spectrometry: Fragmentation Patterns of Amines and Ethers.[2] Virtual Textbook of Organic Chemistry. [\[Link\]](#)
- PubChem. Compound Summary: 1-(2-Phenylethyl)piperidine.[2][6] National Library of Medicine. [\[Link\]](#)[1]

### Need Custom Synthesis?

BenchChem offers custom synthesis for rare earth carbides and specific isotopic labeling.

Email: [info@benchchem.com](mailto:info@benchchem.com) or [Request Quote Online](#).

## Sources

- 1. Mass Spectrometry [[www2.chemistry.msu.edu](http://www2.chemistry.msu.edu)]
- 2. UCSD/CCMS - Spectrum Library [[gnps.ucsd.edu](http://gnps.ucsd.edu)]
- 3. [pdf.benchchem.com](http://pdf.benchchem.com) [[pdf.benchchem.com](http://pdf.benchchem.com)]
- 4. Piperidine, 1-(phenylmethyl)- [[webbook.nist.gov](http://webbook.nist.gov)]
- 5. Piperidine, 1-(2-phenylethyl)- [[webbook.nist.gov](http://webbook.nist.gov)]
- 6. Piperidine, 1-(2-phenylethyl)- | C13H19N | CID 9513 - PubChem [[pubchem.ncbi.nlm.nih.gov](http://pubchem.ncbi.nlm.nih.gov)]
- 7. Ethyl tetrahydrofuran-2-carboxylate | 16874-34-3 | Benchchem [[benchchem.com](http://benchchem.com)]
- 8. Mass Fragmentation Characteristics of Piperazine Analogues [[zpxb.xml-journal.net](http://zpxb.xml-journal.net)]
- To cite this document: BenchChem. [Advanced Characterization Guide: Mass Spectrometry of Phenoxyethyl Piperidines]. BenchChem, [2026]. [Online PDF]. Available at: [<https://www.benchchem.com/product/b3463095/docs#advanced-characterization-guide-mass-spectrometry-of-phenoxyethyl-piperidines>]

---

### Disclaimer & Data Validity:

The information provided in this document is for Research Use Only (RUO) and is strictly not intended for diagnostic or therapeutic procedures. While BenchChem strives to provide accurate protocols, we make no warranties, express or implied, regarding the fitness of this product for every specific experimental setup.

**Technical Support:** The protocols provided are for reference purposes. Unsure if this reagent suits your experiment?

**Need Industrial/Bulk Grade?** [Request Custom Synthesis Quote](#)

## BenchChem

Our mission is to be the trusted global source of essential and advanced chemicals, empowering scientists and researchers to drive progress in science and industry.

### Contact

Address: 3281 E Guasti Rd  
Ontario, CA 91761, United States  
Phone: (601) 213-4426  
Email: [info@benchchem.com](mailto:info@benchchem.com)

[Contact our Ph.D. Support Team for a compatibility check](#)