

Technical Support Center: Optimizing Incubation Times for Alpha-Aescin Experiments

Author: BenchChem Technical Support Team. **Date:** May 2026

Compound of Interest

Compound Name: *alpha-Aescin*

CAS No.: 66795-86-6

Cat. No.: B3434911

[Get Quote](#)

This technical support center provides researchers, scientists, and drug development professionals with comprehensive guidance on optimizing incubation times for experiments involving **alpha-Aescin**. Below, you will find troubleshooting guides and frequently asked questions (FAQs) to address specific issues you may encounter.

Frequently Asked Questions (FAQs)

Q1: What is the optimal incubation time for **alpha-Aescin** in cell culture experiments?

A1: The optimal incubation time for **alpha-Aescin** is highly dependent on the cell type, the concentration of **alpha-Aescin** used, and the specific biological effect being investigated. It is crucial to perform a time-course experiment to determine the ideal incubation period for your specific experimental setup. For instance, cytotoxicity assays may require longer incubation periods (e.g., 24-48 hours) to observe significant effects, while signaling pathway studies might need much shorter time points (minutes to hours).

Q2: I am observing significant cell death even at low concentrations of **alpha-Aescin**. What could be the cause?

A2: Unintended cytotoxicity can arise from several factors. Firstly, ensure the purity of your **alpha-Aescin** stock. Impurities can lead to off-target effects. Secondly, the final concentration of the solvent (e.g., DMSO) used to dissolve **alpha-Aescin** should be kept at a non-toxic level, typically below 0.1%. It is also important to consider the sensitivity of your specific cell line, as some are more susceptible to saponin-induced membrane disruption. A dose-response and time-course cytotoxicity assay (e.g., MTT or LDH assay) is recommended to establish a non-toxic working concentration range for your experiments.

Q3: My **alpha-Aescin** solution is precipitating in the cell culture medium. How can I resolve this?

A3: Saponins like **alpha-Aescin** can have limited solubility in aqueous solutions. To prevent precipitation, prepare a high-concentration stock solution in a suitable organic solvent like DMSO. When preparing your working solution, add the stock solution to your pre-warmed cell culture medium and mix immediately by gentle swirling. Avoid "solvent shock" by not adding the concentrated stock directly to a large volume of cold medium. Performing serial dilutions in the pre-warmed medium can also help maintain solubility.

Q4: I am not observing the expected anti-inflammatory effect of **alpha-Aescin** in my endothelial cell model. What should I check?

A4: The lack of an anti-inflammatory response could be due to several reasons. Verify the inflammatory stimulus (e.g., LPS, TNF- α) is potent enough to induce a measurable response. The concentration and incubation time of **alpha-Aescin** are critical; refer to the data tables below for recommended ranges in similar experimental systems. Consider pre-incubating the cells with **alpha-Aescin** before adding the inflammatory stimulus, as this can often enhance its protective effects. Also, ensure that the endpoint being measured (e.g., cytokine release, adhesion molecule expression) is appropriate for the expected mechanism of action of **alpha-Aescin**.

Troubleshooting Guides

Issue 1: High Variability in Experimental Replicates

- Possible Cause: Inconsistent cell seeding density, uneven scratch creation in wound healing assays, or pipetting errors.

- Troubleshooting Steps:
 - Ensure a homogenous single-cell suspension before seeding.
 - For scratch assays, use a guide to create uniform wounds.
 - Calibrate pipettes regularly and use proper pipetting techniques.
 - Include sufficient biological and technical replicates to assess variability.

Issue 2: Unexpected Morphological Changes in Cells

- Possible Cause: Cytotoxicity at the concentration used, or solvent toxicity.
- Troubleshooting Steps:
 - Perform a dose-response curve to determine the IC50 value and select a sub-toxic concentration for your experiments.
 - Always include a vehicle control (medium with the same final concentration of the solvent) to rule out solvent-induced effects.
 - Visually inspect cells under a microscope at different time points during the incubation period.

Data Presentation: Incubation Times and Concentrations for Alpha-Aescin Experiments

The following tables summarize quantitative data from various studies to guide the optimization of your experimental protocols.

Table 1: Cytotoxicity Assays

Cell Line	Alpha-Aescin Concentration	Incubation Time	Observed Effect
PA-1 (Human Ovarian Cancer)	Up to 200 µg/mL	48 hours	Inhibition of cell viability
C6 (Glioma) & A549 (Lung Adenocarcinoma)	IC50 values: 11.3-23 µg/mL	24 and 48 hours	Dose and time-dependent antiproliferative effects[1]
HUVEC & HVVEC	≥ 15 µg/mL	24 hours	Reduced cell survival[2]

Table 2: Anti-inflammatory Assays

Cell Line	Inflammatory Stimulus	Alpha-Aescin Concentration	Incubation Protocol	Measured Endpoint
HUVECs	Hypoxia (CoCl ₂)	0.1-1 µM	Pre-treatment with Aescin	Prevention of VCAM-1 expression and PECAM-1 reduction[3]
HUVECs	LPS	Not specified	Pre-treatment with Aescin	Reduced IL-6 release[3]
HUVECs	Hypoxia	100-750 ng/mL	120 minutes	Inhibition of ATP decrease and phospholipase A2 activity[4]

Table 3: Wound Healing (Migration) Assays

Cell Line	Alpha-Aescin Concentration	Incubation Time	Key Observation
Bronchial Epithelial Cells	Peptide-dependent	15, 20, and 24 hours	Monitored cell migration to close the gap[4]
General Protocol	Dependent on cell type	24-48 hours	Observation of wound closure[1][3][5][6][7]

Table 4: Neuroprotection Assays

Cell Model	Insult	Alpha-Aescin Concentration	Incubation Protocol	Outcome
Primary Cultured Neurons	Oxygen-Glucose Deprivation (OGD) / Reperfusion	50 µg/mL	2 hours OGD followed by 24 hours reperfusion with Aescin[8]	Attenuated neuronal death and LDH release[8]

Experimental Protocols

Cytotoxicity Assay (MTT Assay)

- **Cell Seeding:** Seed cells in a 96-well plate at a density that allows for logarithmic growth during the experiment and incubate for 24 hours.
- **Treatment:** Prepare serial dilutions of **alpha-Aescin** in complete culture medium. Replace the existing medium with the **alpha-Aescin** solutions. Include a vehicle control (medium with the same concentration of solvent, e.g., DMSO) and an untreated control.
- **Incubation:** Incubate the plate for the desired period (e.g., 24, 48, or 72 hours) at 37°C in a 5% CO₂ incubator.
- **MTT Addition:** Add MTT solution to each well to a final concentration of 0.5 mg/mL and incubate for 2-4 hours at 37°C.

- Solubilization: Remove the MTT solution and add DMSO to each well to dissolve the formazan crystals.
- Measurement: Read the absorbance at 570 nm using a microplate reader.

Scratch (Wound Healing) Assay

- Cell Seeding: Seed cells in a 6-well or 12-well plate and grow them to form a confluent monolayer.
- Scratch Creation: Create a "scratch" in the monolayer using a sterile pipette tip.
- Washing: Gently wash the wells with PBS to remove detached cells.
- Treatment: Add fresh medium containing the desired concentration of **alpha-Aescin** or vehicle control.
- Imaging: Capture images of the scratch at time 0 and at subsequent time points (e.g., every 6, 12, or 24 hours) using a microscope.[\[3\]](#)[\[4\]](#)[\[5\]](#)[\[6\]](#)[\[7\]](#)
- Analysis: Measure the width of the scratch at different time points to quantify the rate of cell migration and wound closure.

Neuroprotection Assay (Oxygen-Glucose Deprivation Model)

- Cell Culture: Culture primary neurons or a neuronal cell line to the desired confluency.
- OGD Induction: Replace the normal culture medium with glucose-free medium and place the cells in a hypoxic chamber (e.g., 1% O₂, 5% CO₂, 94% N₂) for a specified period (e.g., 2 hours).[\[8\]](#)
- Reperfusion: After the OGD period, replace the glucose-free medium with normal culture medium containing different concentrations of **alpha-Aescin** or vehicle. Return the cells to a normoxic incubator (37°C, 5% CO₂).
- Incubation: Incubate for a desired reperfusion period (e.g., 24 hours).[\[8\]](#)

- Assessment: Evaluate neuronal viability using methods such as LDH assay for cytotoxicity or cell viability assays.

Mandatory Visualizations

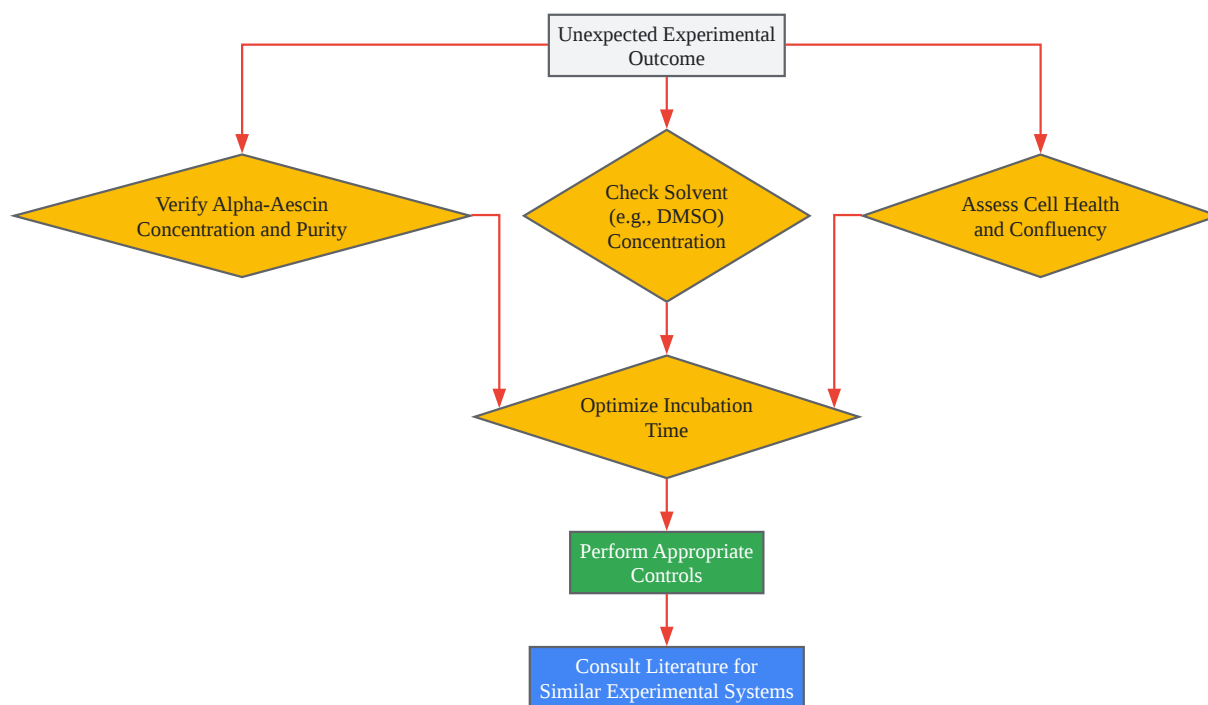
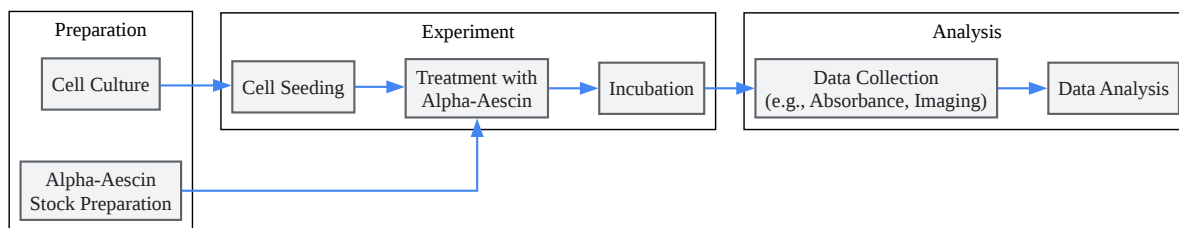

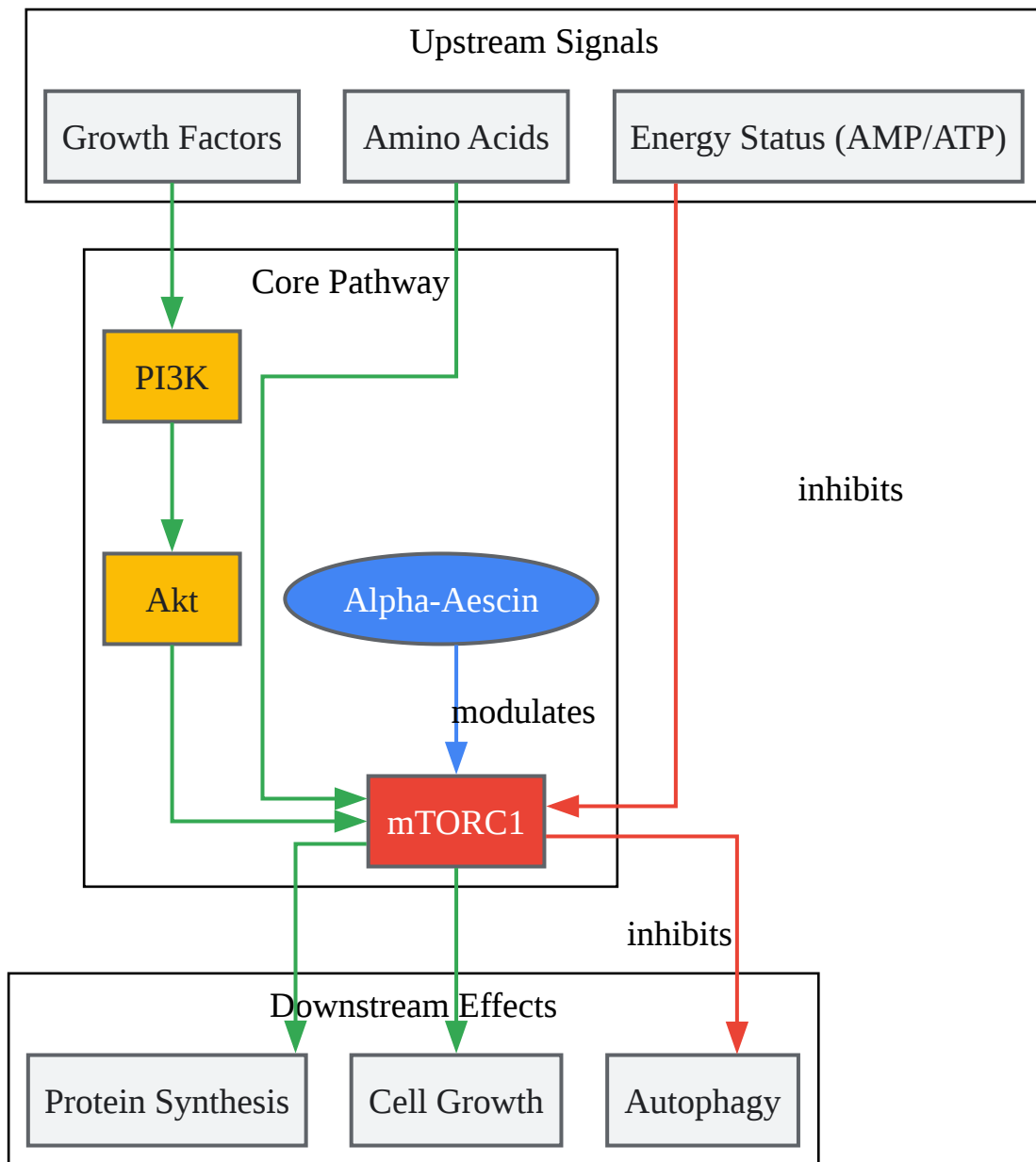

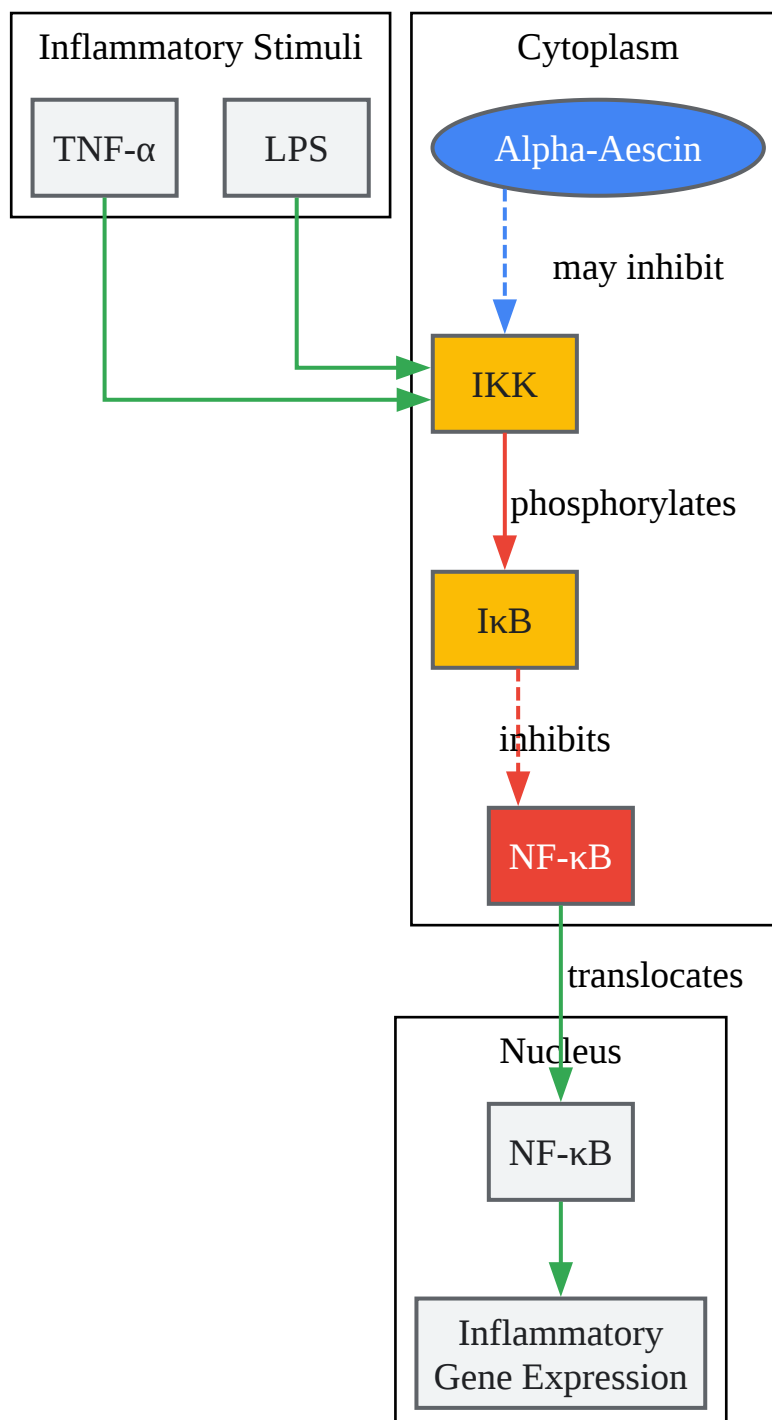

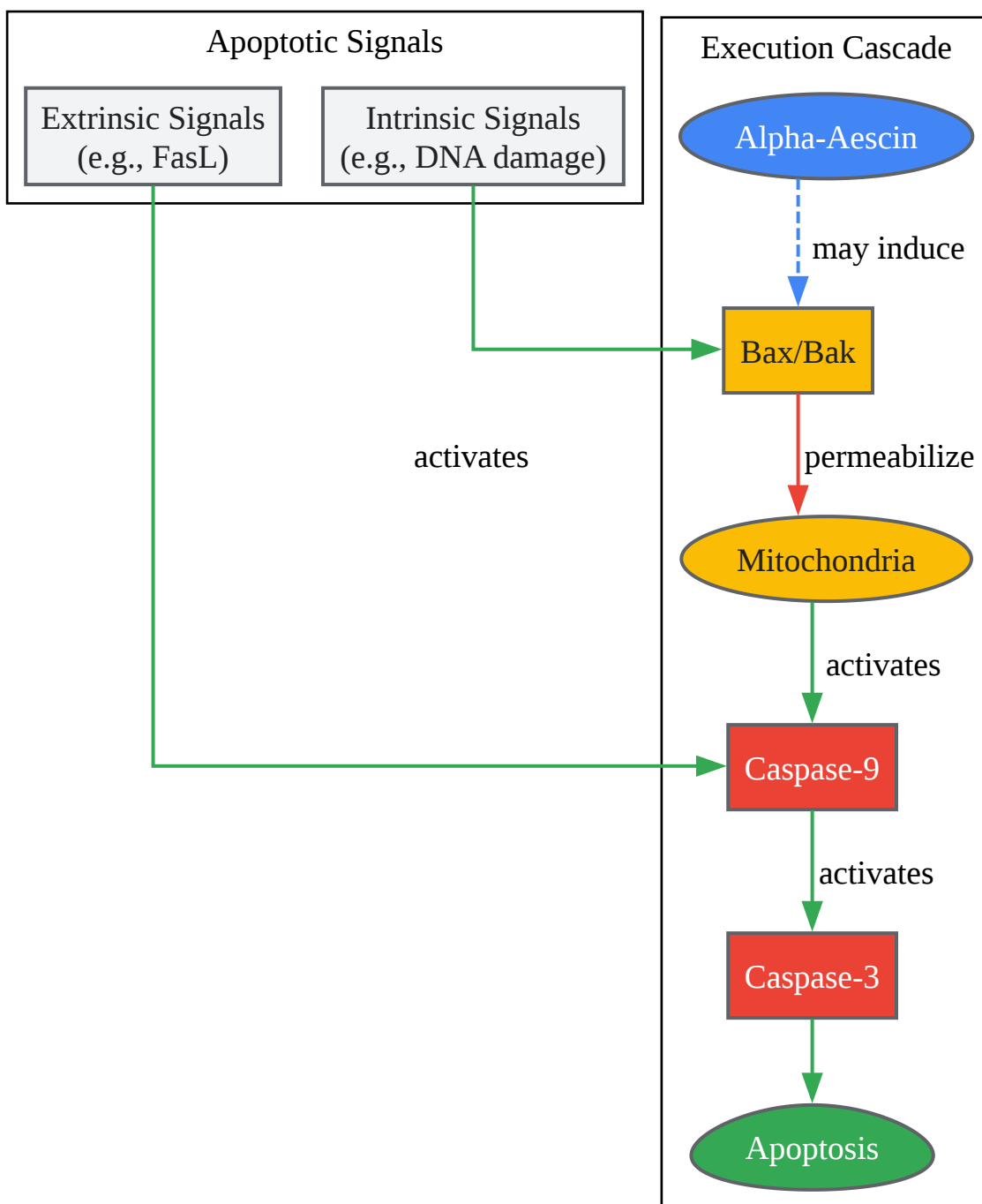

[Click to download full resolution via product page](#)

Need Custom Synthesis?

BenchChem offers custom synthesis for rare earth carbides and specific isotopic labeling.

Email: info@benchchem.com or [Request Quote Online](#).

References

- [1. clyte.tech \[clyte.tech\]](#)
- [2. In Vitro Cytotoxic Action of Aesculus Hippocastanum Extract Against PA 1 Human Ovarian Cell-Line – Biomedical and Pharmacology Journal \[biomedpharmajournal.org\]](#)
- [3. researchgate.net \[researchgate.net\]](#)
- [4. scienceopen.com \[scienceopen.com\]](#)
- [5. med.virginia.edu \[med.virginia.edu\]](#)
- [6. scispace.com \[scispace.com\]](#)
- [7. Wound healing migration assay \(Scratch assay\) \[protocols.io\]](#)
- [8. Aescin Protects Neuron from Ischemia-Reperfusion Injury via Regulating the PRAS40/mTOR Signaling Pathway - PubMed \[pubmed.ncbi.nlm.nih.gov\]](#)
- To cite this document: BenchChem. [Technical Support Center: Optimizing Incubation Times for Alpha-Aescin Experiments]. BenchChem, [2026]. [Online PDF]. Available at: [\[https://www.benchchem.com/product/b3434911/docs#technical-support-center-optimizing-incubation-times-for-alpha-aescin-experiments\]](https://www.benchchem.com/product/b3434911/docs#technical-support-center-optimizing-incubation-times-for-alpha-aescin-experiments)

Disclaimer & Data Validity:

The information provided in this document is for Research Use Only (RUO) and is strictly not intended for diagnostic or therapeutic procedures. While BenchChem strives to provide accurate protocols, we make no warranties, express or implied, regarding the fitness of this product for every specific experimental setup.

Technical Support: The protocols provided are for reference purposes. Unsure if this reagent suits your experiment?

Need Industrial/Bulk Grade? [Request Custom Synthesis Quote](#)

BenchChem

Our mission is to be the trusted global source of essential and advanced chemicals, empowering scientists and researchers to drive progress in science and industry.

Contact

Address: 3281 E Guasti Rd

Ontario, CA 91761, United States

Phone: (601) 213-4426

Email: info@benchchem.com

[Contact our Ph.D. Support Team for a compatibility check](#)