

dealing with instrument contamination in trace 2-Ethylfenchol analysis

Author: BenchChem Technical Support Team. **Date:** April 2026

Compound of Interest

Compound Name: 2-Ethylfenchol

CAS No.: 137255-07-3

Cat. No.: B3432381

[Get Quote](#)

Technical Support Center: Trace 2-Ethylfenchol Analysis

Welcome to the technical support center for the trace analysis of **2-Ethylfenchol**. This guide is designed for researchers, scientists, and drug development professionals to provide expert advice and troubleshooting strategies for the challenges associated with detecting low levels of this semi-volatile organic compound. As a Senior Application Scientist, my goal is to combine established scientific principles with practical, field-tested insights to help you achieve accurate and reliable results.

Introduction to Trace 2-Ethylfenchol Analysis

2-Ethylfenchol is a tertiary alcohol known for its characteristic earthy and camphor-like aroma. [1][2] It is used as a fragrance and flavor ingredient and can be found in a variety of consumer products.[3] Its semi-volatile nature and presence in complex matrices can make trace-level quantification challenging. The primary analytical technique for this compound is Gas Chromatography-Mass Spectrometry (GC-MS), often requiring careful sample preparation to achieve the necessary sensitivity and selectivity.[4][5][6]

A significant hurdle in trace analysis is the ubiquitous nature of background contamination, which can mask the analyte signal, lead to false positives, and compromise the integrity of your data. This guide will provide a systematic approach to identifying and eliminating these contamination sources.

Frequently Asked Questions (FAQs)

Here, we address some of the most common questions and issues encountered during the trace analysis of **2-Ethylfenchol**.

Q1: I'm seeing unexpected peaks in my blank runs, often referred to as "ghost peaks." What are they, and where are they coming from?

A1: Ghost peaks are signals in your chromatogram that do not originate from your sample.^[7] They are a classic sign of contamination within your analytical system. For semi-volatile compounds like **2-Ethylfenchol**, the most common culprits are:

- **Phthalates:** These plasticizers are found in a vast array of laboratory consumables, including solvent bottles, pipette tips, vial caps, and even some plastic tubing.^[8] They can leach into your solvents and samples, causing significant background interference.
- **Siloxanes:** These silicon-containing compounds are another major source of contamination, often originating from the GC septum, vial septa, or column bleed.^[9]
- **Carryover:** This occurs when a small amount of a previous, more concentrated sample remains in the injection port or at the head of the analytical column, and then elutes during a subsequent run.^[7]

Q2: How can I determine the source of the contamination in my GC-MS system?

A2: A systematic approach is key to pinpointing the source of contamination. The following workflow can help you isolate the problem:

Troubleshooting Workflow for Ghost Peaks

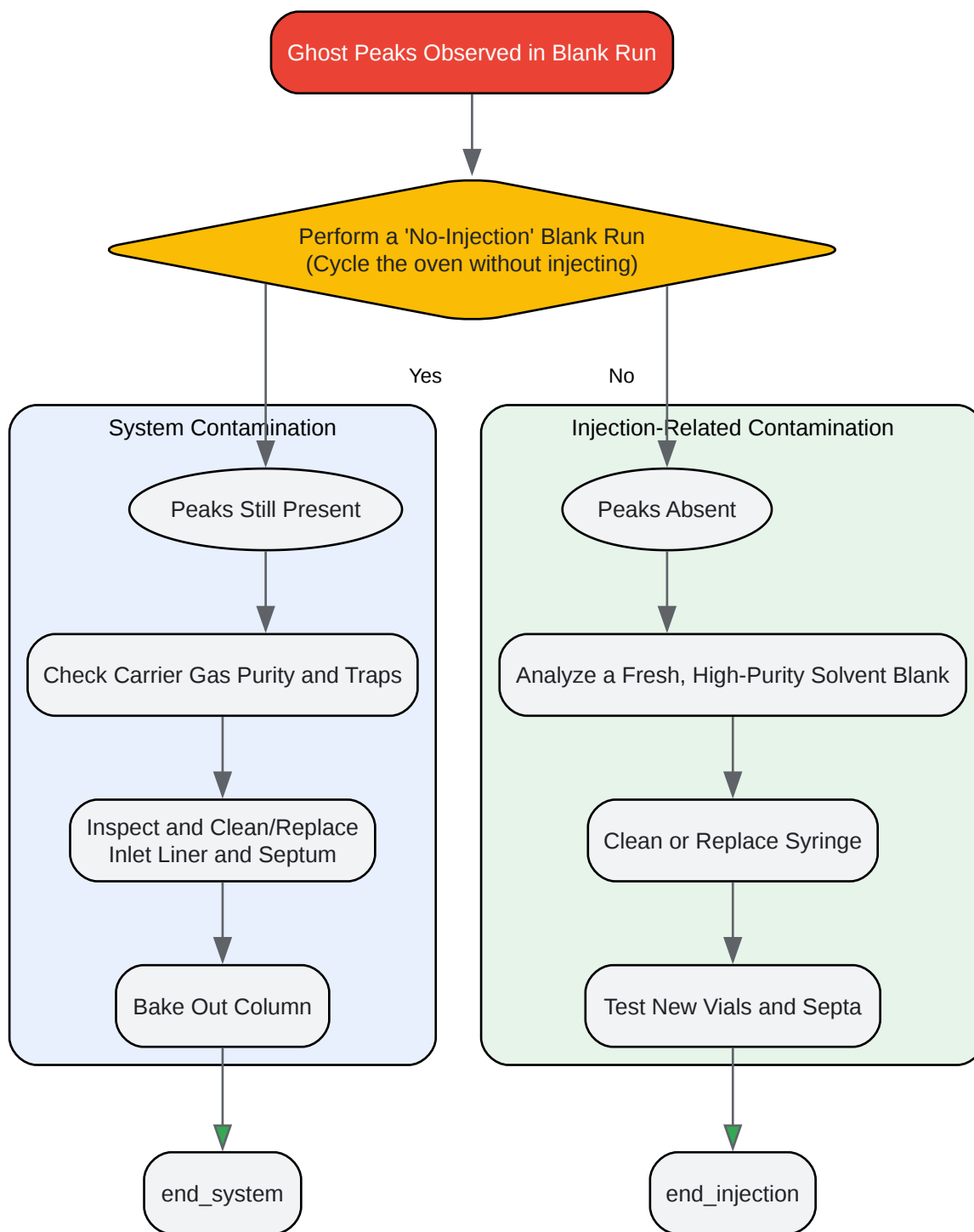

[Click to download full resolution via product page](#)

Caption: A logical workflow for diagnosing the source of ghost peaks.

Q3: What are the best practices for cleaning my GC-MS system to remove contamination?

A3: Regular and thorough cleaning of your GC-MS system is crucial for maintaining low background levels. Here are some key procedures:

- **Inlet Maintenance:** The injection port is a common site for contamination to accumulate. Regularly replace the septum and inlet liner. For persistent contamination, the inlet itself may need to be disassembled and cleaned with appropriate solvents.
- **Column Care:** If the contamination is suspected to be at the head of the column, you can often resolve the issue by trimming the first 10-15 cm of the column. For more widespread contamination, a column bakeout at the maximum recommended temperature (without exceeding it) can be effective.[\[10\]](#)
- **Ion Source Cleaning:** Over time, non-volatile residues can build up in the ion source, leading to reduced sensitivity and increased background noise. The ion source should be cleaned according to the manufacturer's instructions. This typically involves disassembly and mechanical cleaning of the metal components.

Q4: Are there specific sample preparation techniques that can help minimize contamination for 2-Ethylfenchol analysis?

A4: Yes, your sample preparation workflow is a critical control point for contamination.

- **Solvent Purity:** Always use the highest purity solvents available for your sample extraction and dilution steps. It is good practice to run a solvent blank from a new bottle to confirm its cleanliness.
- **Glassware:** Whenever possible, use glassware instead of plastic for sample preparation and storage. If plasticware is unavoidable, ensure it is made of a material known to have low leachables, such as polypropylene. A thorough cleaning procedure for all labware is essential.[\[11\]](#)

- Extraction Techniques: For complex matrices, a selective sample preparation technique like Solid-Phase Extraction (SPE) or Liquid-Liquid Extraction (LLE) can help to isolate **2-Ethylfenchol** from potential interferences and matrix components.[\[4\]](#)[\[12\]](#)

Troubleshooting Guide: Specific Issues in 2-Ethylfenchol Analysis

This section provides a more in-depth look at specific problems you might encounter and how to resolve them.

Observed Problem	Potential Causes	Recommended Actions
Poor Peak Shape (Tailing)	<ul style="list-style-type: none"> - Active sites in the inlet liner or column. - Column contamination. - Improper column installation. 	<ul style="list-style-type: none"> - Use a deactivated inlet liner. - Trim the front of the column or replace it. - Ensure the column is installed correctly according to the manufacturer's guidelines.[6]
Poor Reproducibility	<ul style="list-style-type: none"> - Leaks in the injection system. - Inconsistent injection volume. - Sample degradation. 	<ul style="list-style-type: none"> - Perform a leak check of the inlet. - Ensure the autosampler syringe is functioning correctly. - Check the stability of 2-Ethylfenchol in your sample matrix and standards.
Low Sensitivity/Recovery	<ul style="list-style-type: none"> - Matrix effects (ion suppression or enhancement). - Inefficient extraction. - Adsorption of the analyte to active sites. 	<ul style="list-style-type: none"> - Use a matrix-matched calibration curve. - Optimize your SPE or LLE method. - Ensure all components of the sample path are properly deactivated.
Matrix Interferences	<ul style="list-style-type: none"> - Co-elution with other compounds in the sample. - Inadequate sample cleanup. 	<ul style="list-style-type: none"> - Adjust the GC temperature program to improve separation. - Employ a more selective sample preparation method. - For complex matrices like cannabis, be aware of potential interference from terpenes.[13]

Experimental Protocols

Below are example protocols that can be adapted for your specific application.

Protocol 1: General GC-MS Screening Method for Semi-Volatiles

This method can be used as a starting point for the analysis of **2-Ethylfenchol**.

- GC System: Agilent 7890B or equivalent
- MS System: Agilent 5977A or equivalent
- Column: HP-5MS (30 m x 0.25 mm, 0.25 μ m) or equivalent 5% phenyl methyl siloxane column
- Injection Volume: 1 μ L
- Injector Temperature: 250°C
- Oven Temperature Program:
 - Initial temperature: 60°C, hold for 2 minutes
 - Ramp: 10°C/min to 280°C
 - Hold at 280°C for 5 minutes
- Carrier Gas: Helium at a constant flow of 1 mL/min
- MS Transfer Line Temperature: 280°C
- Ion Source Temperature: 230°C
- Ionization Mode: Electron Ionization (EI) at 70 eV
- Scan Mode: Selected Ion Monitoring (SIM) for target analysis, using characteristic ions for **2-Ethylfenchol**.

Protocol 2: Liquid-Liquid Extraction (LLE) for Aqueous Samples

This protocol is suitable for extracting **2-Ethylfenchol** from water or beverage samples.^{[4][5]}

- To a 100 mL sample in a separatory funnel, add an appropriate internal standard.

- Add 30 mL of a suitable extraction solvent (e.g., dichloromethane or a hexane/diethyl ether mixture).
- Shake vigorously for 2-3 minutes, periodically venting the funnel.
- Allow the layers to separate and drain the organic layer into a collection flask.
- Repeat the extraction two more times with fresh solvent.
- Combine the organic extracts and dry over anhydrous sodium sulfate.
- Concentrate the extract to a final volume of 1 mL under a gentle stream of nitrogen.
- The extract is now ready for GC-MS analysis.

Visualization of Contamination Pathways

The following diagram illustrates the various points at which contamination can be introduced into your analytical workflow.

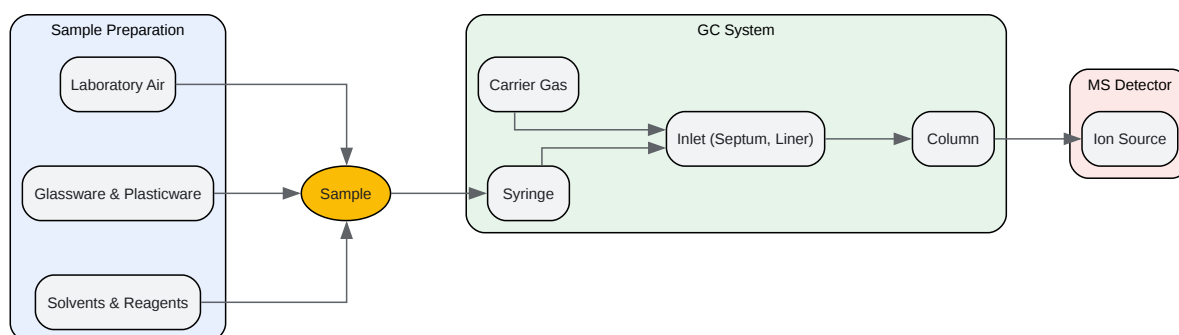

[Click to download full resolution via product page](#)

Caption: Potential sources of contamination in the analytical workflow.

Conclusion

Achieving reliable and accurate results in trace **2-Ethylfenchol** analysis is a matter of meticulous attention to detail and a systematic approach to troubleshooting. By understanding the potential sources of contamination and implementing the preventative and corrective actions outlined in this guide, you can significantly improve the quality of your data. Remember that a clean and well-maintained instrument is the foundation of high-quality trace analysis.

References

- Lu, C. H., et al. (2021). Quantitative analysis of fragrance allergens in various matrixes of cosmetics by liquid-liquid extraction and GC-MS. *Journal of Food and Drug Analysis*, 29(4), 658-671. [[Link](#)]
- David, F., et al. (n.d.). Analysis of Suspected Flavor and Fragrance Allergens in Cosmetics Using the 7890A GC and Capillary Column Backflush Application. Agilent Technologies. [[Link](#)]
- The Good Scents Company. (n.d.). 2-ethyl fenchol. Retrieved from [[Link](#)]
- EPA. (n.d.). EPA Method 8260D (SW-846): Volatile Organic Compounds by Gas Chromatography-Mass Spectrometry (GC/MS). Retrieved from [[Link](#)]
- Shimadzu. (n.d.). Quantitative Analysis of 57 Fragrance Allergens in Cosmetics Using Twin Line MS System. Retrieved from [[Link](#)]
- Teklab, Inc. (n.d.). EPA Method 8260 Testing. Retrieved from [[Link](#)]
- Agilent Technologies. (2024). Highly Selective GC/TQ Analysis of 57 Allergens in Cosmetic Products. Retrieved from [[Link](#)]
- Whitehead, P. (2020). Minimizing Contamination During Sample Preparation For Trace Analysis. ELGA LabWater. Retrieved from [[Link](#)]
- Terpene Belt Farms. (2025). Cannabis-Derived Terpene Testing: Methods for Accurate Solvent Analysis. Retrieved from [[Link](#)]
- Labcompare. (2022). LABTips: Troubleshooting Tricky Terpenes. Retrieved from [[Link](#)]

- SCIEX. (n.d.). Comprehensive Cannabis Analysis-Pesticides, Aflatoxins, Terpenes. Retrieved from [\[Link\]](#)
- News-Medical.net. (2024). Fragrance And Flavor Component Analysis: Techniques And Applications. Retrieved from [\[Link\]](#)
- Phenomenex. (n.d.). GC Troubleshooting Guide. Retrieved from [\[Link\]](#)
- A.D.L.M. (2022). How to Avoid Analytical Interferences in Trace Element Analysis. Retrieved from [\[Link\]](#)
- Spectroscopy Online. (2026). A Common Sense Laboratory Guide to Reducing Errors and Contamination in ICP and ICP-MS Analysis. Retrieved from [\[Link\]](#)
- Freyr. (2021). Regulation of Fragrances According to the US FDA. Retrieved from [\[Link\]](#)
- Ministry of the Environment, Government of Japan. (n.d.). III Analytical Methods. Retrieved from [\[Link\]](#)
- U.S. Geological Survey. (n.d.). Methods of Analysis by the US Geological Survey. Retrieved from [\[Link\]](#)
- Mosaic Flavors. (n.d.). FDA Regulations for Flavorings. Retrieved from [\[Link\]](#)
- Cannabis Masters. (2021). Accurate Terpene Analysis. Retrieved from [\[Link\]](#)
- Agilent Technologies. (n.d.). GC Troubleshooting Guide Poster. Retrieved from [\[Link\]](#)
- Separation Science. (2023). Get your GC-MS troubleshooting guide now!. Retrieved from [\[Link\]](#)
- Shimadzu. (n.d.). Gas Chromatography Mass Spectrometry Troubleshooting Guide. Retrieved from [\[Link\]](#)
- Journal of Chromatography A. (n.d.). Retrieved from [\[Link\]](#)
- FSSAI. (n.d.). MANUAL OF METHODS OF ANALYSIS OF FOODS. Retrieved from [\[Link\]](#)

- OIV. (n.d.). Determination of the principal volatile substances in spirit drinks of viti-vinicultural (Type II). Retrieved from [\[Link\]](#)
- EPA. (n.d.). Method 528 - Determination of Phenols in Drinking Water by Solid Phase Extraction and Capillary Column Gas Chromatography/Mass Spectrometry. Retrieved from [\[Link\]](#)
- Scientific Laboratory Supplies. (n.d.). **2-Ethylfenchol**, >=97%, FCC. Retrieved from [\[Link\]](#)
- Umweltbundesamt. (n.d.). Method development for analysis of pharmaceuticals in environmental samples. Retrieved from [\[Link\]](#)
- SciSpace. (n.d.). Top 780 Journal of Chromatography A papers published in 2021. Retrieved from [\[Link\]](#)
- PubMed. (2017). Evaluation and prevention of the negative matrix effect of terpenoids on pesticides in apples quantification by gas chromatography-tandem mass spectrometry. Retrieved from [\[Link\]](#)

Need Custom Synthesis?

BenchChem offers custom synthesis for rare earth carbides and specific isotopic labeling.

Email: info@benchchem.com or [Request Quote Online](#).

Sources

- 1. scientificlabs.co.uk [scientificlabs.co.uk]
- 2. 2-Ethylfenchol = 97 , FCC, FG 18368-91-7 [sigmaaldrich.com]
- 3. 2-ethyl fenchol, 18368-91-7 [thegoodscentcompany.com]
- 4. jfda-online.com [jfda-online.com]
- 5. Quantitative analysis of fragrance allergens in various matrixes of cosmetics by liquid–liquid extraction and GC–MS - PMC [pmc.ncbi.nlm.nih.gov]
- 6. GC Column Troubleshooting Guide | Phenomenex [phenomenex.com]
- 7. sepscience.com [sepscience.com]

- [8. elgalabwater.com](http://8.elgalabwater.com) [elgalabwater.com]
- [9. shimadzu.co.uk](http://9.shimadzu.co.uk) [shimadzu.co.uk]
- [10. agilent.com](http://10.agilent.com) [agilent.com]
- [11. pdf.benchchem.com](http://11.pdf.benchchem.com) [pdf.benchchem.com]
- [12. env.go.jp](http://12.env.go.jp) [env.go.jp]
- [13. cannabismasters.eu](http://13.cannabismasters.eu) [cannabismasters.eu]
- To cite this document: BenchChem. [dealing with instrument contamination in trace 2-Ethylfenchol analysis]. BenchChem, [2026]. [Online PDF]. Available at: [<https://www.benchchem.com/product/b3432381/docs#dealing-with-instrument-contamination-in-trace-2-ethylfenchol-analysis>]

Disclaimer & Data Validity:

The information provided in this document is for Research Use Only (RUO) and is strictly not intended for diagnostic or therapeutic procedures. While BenchChem strives to provide accurate protocols, we make no warranties, express or implied, regarding the fitness of this product for every specific experimental setup.

Technical Support: The protocols provided are for reference purposes. Unsure if this reagent suits your experiment?

Need Industrial/Bulk Grade? [Request Custom Synthesis Quote](#)

BenchChem

Our mission is to be the trusted global source of essential and advanced chemicals, empowering scientists and researchers to drive progress in science and industry.

Contact

Address: 3281 E Guasti Rd
Ontario, CA 91761, United States
Phone: (601) 213-4426
Email: info@benchchem.com

Contact our Ph.D. Support Team for a compatibility check