

Application Notes and Protocols for Studying Drug Resistance Using ML264

Author: BenchChem Technical Support Team. **Date:** April 2026

Compound of Interest

Compound Name: (E/Z)-BML264

CAS No.: 99196-74-4

Cat. No.: B3432251

[Get Quote](#)

For Researchers, Scientists, and Drug Development Professionals

Introduction

Drug resistance is a significant challenge in cancer therapy, leading to treatment failure and disease progression. Understanding the molecular mechanisms underlying drug resistance is crucial for the development of novel therapeutic strategies. ML264 is a potent and specific small-molecule inhibitor of Krüppel-like factor 5 (KLF5), a transcription factor implicated in cell proliferation, survival, and tumorigenesis. Recent studies have highlighted the role of KLF5 in cancer progression and its potential as a therapeutic target. ML264 exerts its anti-cancer effects by inhibiting the JAK2/STAT3 and Wnt/ β -catenin signaling pathways.[1] These pathways are known to be involved in the development of drug resistance in various cancers. These application notes provide detailed protocols for utilizing ML264 to investigate and potentially overcome drug resistance in cancer cell lines.

Mechanism of Action of ML264

ML264 is a small-molecule compound that has been identified as an inhibitor of KLF5 expression.[1] It also downregulates the expression of the transcriptional activator of KLF5, the

early growth response gene 1 (EGR1).[1] The primary signaling pathways affected by ML264 are the JAK2/STAT3 and Wnt/ β -catenin pathways.[1]

- **JAK2/STAT3 Pathway:** This pathway is crucial for cytokine signaling and is often constitutively activated in cancer, promoting cell proliferation, survival, and invasion. ML264 has been shown to inhibit the phosphorylation of STAT3, a key downstream effector in this pathway.[1]
- **Wnt/ β -catenin Pathway:** The Wnt signaling pathway plays a critical role in embryonic development and tissue homeostasis. Its aberrant activation in cancer leads to the accumulation of β -catenin in the nucleus, where it acts as a transcriptional co-activator of genes involved in cell proliferation and survival. ML264 has been observed to inhibit Wnt signaling.[1]

By inhibiting these key signaling pathways, ML264 can suppress cancer cell growth, induce cell cycle arrest, and inhibit migration and invasion.[1] Its ability to modulate pathways frequently implicated in drug resistance makes it a valuable tool for studying and potentially reversing resistance to conventional chemotherapeutic agents.

Quantitative Data

The following table summarizes the reported effects of ML264 on various cancer cell lines. While specific data on drug-resistant lines is limited in the public domain, the provided data on sensitive lines can serve as a baseline for resistance studies. Researchers are encouraged to generate similar data in their specific drug-resistant models.

Cell Line	Cancer Type	Assay	Endpoint	ML264 Concentration	Result	Reference
143B	Osteosarcoma	Proliferation Assay	Cell Viability	0-20 μ M	Dose-dependent decrease	[1]
U2OS	Osteosarcoma	Proliferation Assay	Cell Viability	0-20 μ M	Dose-dependent decrease	[1]
143B	Osteosarcoma	Clonogenic Assay	Colony Formation	0, 5, 10 μ M	Dose-dependent decrease	[1]
U2OS	Osteosarcoma	Clonogenic Assay	Colony Formation	0, 2.5, 5 μ M	Dose-dependent decrease	[1]
143B	Osteosarcoma	Cell Cycle Analysis	G0/G1 Arrest	10 μ M	Increase in G0/G1 population	[1]
U2OS	Osteosarcoma	Cell Cycle Analysis	G0/G1 Arrest	5 μ M	Increase in G0/G1 population	[1]
143B	Osteosarcoma	Western Blot	p-STAT3	10 μ M	Decreased expression	[1]
U2OS	Osteosarcoma	Western Blot	p-STAT3	5 μ M	Decreased expression	[1]
143B	Osteosarcoma	Western Blot	β -catenin	10 μ M	Decreased expression	[1]
U2OS	Osteosarcoma	Western Blot	β -catenin	5 μ M	Decreased expression	[1]

Experimental Protocols

Here we provide detailed protocols for key experiments to study the effects of ML264 on drug-resistant cancer cells.

Protocol 1: Development of Drug-Resistant Cancer Cell Lines

This protocol describes a general method for generating drug-resistant cancer cell lines through continuous exposure to a chemotherapeutic agent.

Materials:

- Parental cancer cell line of interest
- Complete cell culture medium (e.g., DMEM or RPMI-1640 with 10% FBS and 1% Penicillin-Streptomycin)
- Chemotherapeutic agent (e.g., Paclitaxel, Doxorubicin, Cisplatin)
- Phosphate-Buffered Saline (PBS)
- Trypsin-EDTA
- Cell culture flasks and plates
- Incubator (37°C, 5% CO₂)

Procedure:

- Determine the IC₅₀ of the chemotherapeutic agent:
 - Seed parental cells in a 96-well plate.
 - Treat the cells with a range of concentrations of the chemotherapeutic agent for 48-72 hours.
 - Perform a cell viability assay (e.g., MTT or CellTiter-Glo) to determine the half-maximal inhibitory concentration (IC₅₀).

- Initial Exposure:
 - Culture the parental cells in a medium containing the chemotherapeutic agent at a concentration equal to the IC10-IC20 (the concentration that inhibits 10-20% of cell growth).[2]
 - Incubate the cells for 2-3 days.[2]
- Recovery and Escalation:
 - Replace the drug-containing medium with a fresh, drug-free medium and allow the cells to recover and reach 70-80% confluency.[2]
 - Passage the surviving cells and re-expose them to the medium with the same concentration of the drug.
 - Once the cells show stable growth in the presence of the drug, gradually increase the concentration of the chemotherapeutic agent in a stepwise manner.
- Establishment of Resistant Line:
 - Continue this process of exposure, recovery, and dose escalation for several months.
 - The resulting cell population that can proliferate in a significantly higher concentration of the drug (typically 5-10 times the original IC50) is considered the drug-resistant cell line.
- Validation:
 - Confirm the drug-resistant phenotype by performing a cell viability assay and comparing the IC50 value of the resistant line to that of the parental line. A significant increase in the IC50 value indicates the successful establishment of a drug-resistant cell line.[3]

Protocol 2: Cell Viability Assay to Assess ML264 Efficacy

This protocol details the use of an MTT assay to determine the effect of ML264 on the viability of parental and drug-resistant cells.

Materials:

- Parental and drug-resistant cancer cell lines
- Complete cell culture medium
- ML264 (dissolved in DMSO)
- MTT solution (5 mg/mL in PBS)
- DMSO
- 96-well plates
- Microplate reader

Procedure:

- Cell Seeding:
 - Trypsinize and count the parental and drug-resistant cells.
 - Seed the cells in 96-well plates at a density of 5,000-10,000 cells per well in 100 μ L of complete medium.
 - Incubate for 24 hours to allow for cell attachment.
- ML264 Treatment:
 - Prepare serial dilutions of ML264 in a complete medium. Typical final concentrations to test range from 0.1 to 50 μ M.
 - Include a vehicle control (DMSO) at the same final concentration as in the highest ML264 treatment.
 - Remove the old medium from the wells and add 100 μ L of the medium containing the different concentrations of ML264.
 - Incubate the plates for 48-72 hours.

- MTT Assay:
 - Add 20 μ L of MTT solution to each well and incubate for 4 hours at 37°C.
 - Carefully remove the medium and add 150 μ L of DMSO to each well to dissolve the formazan crystals.
 - Shake the plate gently for 10 minutes.
- Data Analysis:
 - Measure the absorbance at 570 nm using a microplate reader.
 - Calculate the percentage of cell viability relative to the vehicle-treated control cells.
 - Plot the cell viability against the ML264 concentration and determine the IC50 values for both parental and drug-resistant cell lines.

Protocol 3: Western Blot Analysis of Signaling Pathways

This protocol is for analyzing the effect of ML264 on the protein expression levels in the JAK2/STAT3 and Wnt/ β -catenin pathways.

Materials:

- Parental and drug-resistant cancer cell lines
- Complete cell culture medium
- ML264
- RIPA buffer with protease and phosphatase inhibitors
- BCA protein assay kit
- SDS-PAGE gels
- PVDF membrane

- Primary antibodies (e.g., anti-p-STAT3, anti-STAT3, anti- β -catenin, anti-GAPDH)
- HRP-conjugated secondary antibodies
- Enhanced chemiluminescence (ECL) substrate

Procedure:

- Cell Treatment and Lysis:
 - Seed parental and drug-resistant cells in 6-well plates and grow to 70-80% confluency.
 - Treat the cells with ML264 at the desired concentration (e.g., IC50) for 24 hours. Include a vehicle control.
 - Wash the cells with ice-cold PBS and lyse them with RIPA buffer.
 - Centrifuge the lysates at 14,000 rpm for 15 minutes at 4°C and collect the supernatants.
- Protein Quantification:
 - Determine the protein concentration of each lysate using the BCA protein assay.
- SDS-PAGE and Western Blotting:
 - Denature equal amounts of protein (20-30 μ g) by boiling in Laemmli buffer.
 - Separate the proteins by SDS-PAGE and transfer them to a PVDF membrane.
 - Block the membrane with 5% non-fat milk or BSA in TBST for 1 hour at room temperature.
 - Incubate the membrane with the primary antibody overnight at 4°C.
 - Wash the membrane with TBST and incubate with the HRP-conjugated secondary antibody for 1 hour at room temperature.
 - Wash the membrane again and detect the protein bands using an ECL substrate and an imaging system.

- Data Analysis:
 - Quantify the band intensities using image analysis software (e.g., ImageJ).
 - Normalize the expression of the target proteins to a loading control (e.g., GAPDH).
 - Compare the protein expression levels between treated and untreated cells in both parental and resistant lines.

Visualizations

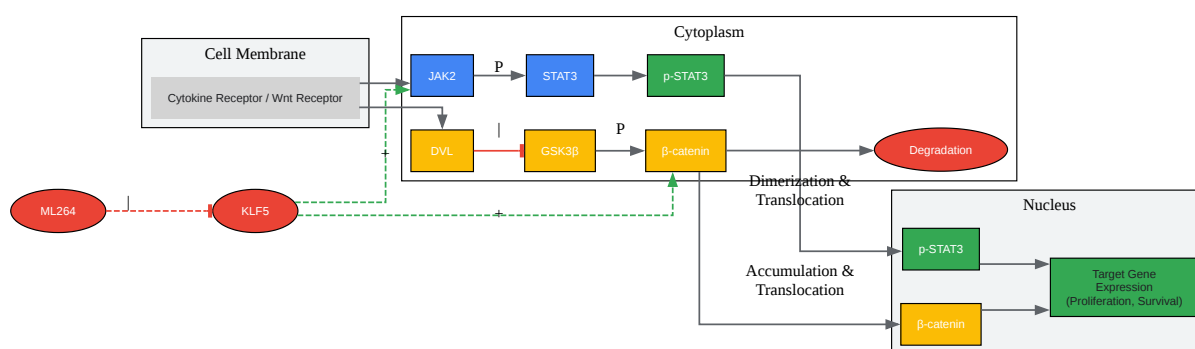

[Click to download full resolution via product page](#)

Caption: Mechanism of action of ML264 in cancer cells.

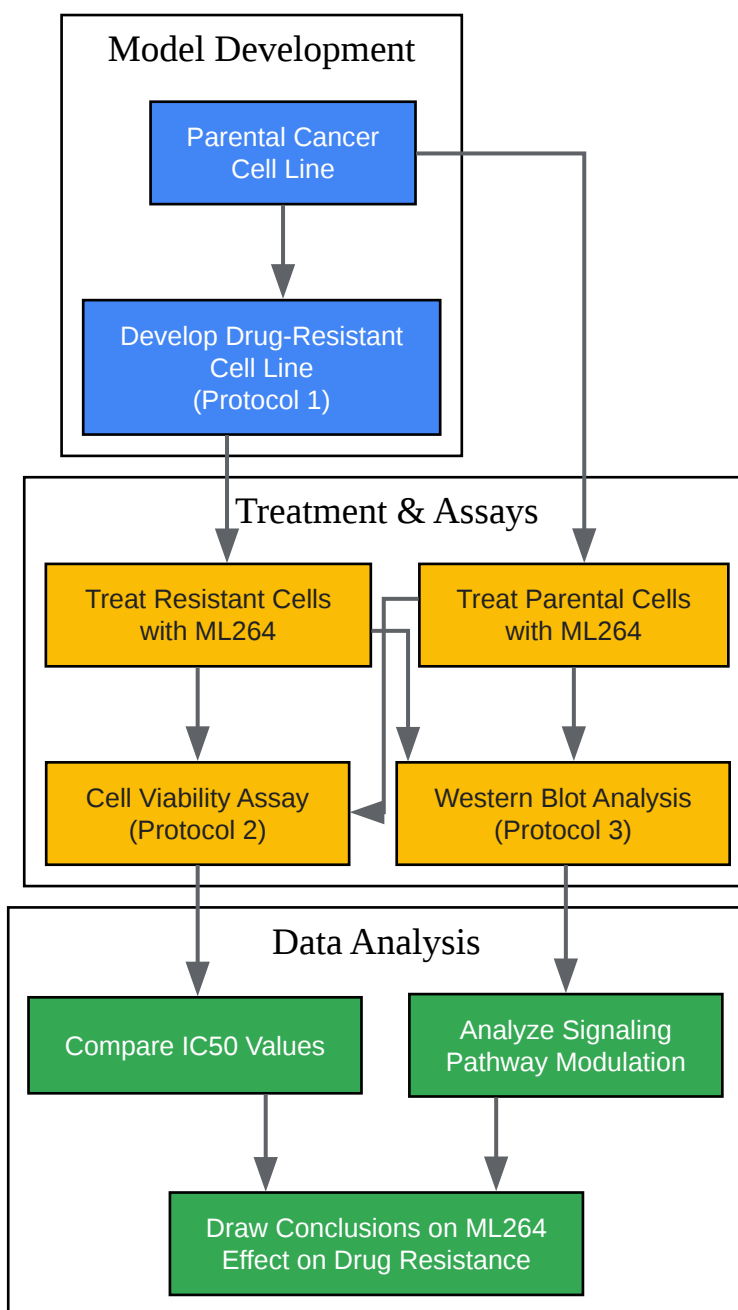

[Click to download full resolution via product page](#)

Caption: Workflow for studying drug resistance with ML264.

Need Custom Synthesis?

BenchChem offers custom synthesis for rare earth carbides and specific isotopic labeling.

Email: info@benchchem.com or [Request Quote Online](#).

References

- 1. ML264 inhibits osteosarcoma growth and metastasis via inhibition of JAK2/STAT3 and WNT/ β -catenin signalling pathways - PMC [[pmc.ncbi.nlm.nih.gov](https://pubmed.ncbi.nlm.nih.gov/)]
- 2. Development of Drug-resistant Cell Lines for Experimental Procedures - PMC [[pmc.ncbi.nlm.nih.gov](https://pubmed.ncbi.nlm.nih.gov/)]
- 3. Development of Drug-resistant Cell Lines for Experimental Procedures - PubMed [pubmed.ncbi.nlm.nih.gov]
- To cite this document: BenchChem. [Application Notes and Protocols for Studying Drug Resistance Using ML264]. BenchChem, [2026]. [Online PDF]. Available at: [<https://www.benchchem.com/product/b3432251/docs#application-notes-and-protocols-for-studying-drug-resistance-using-ml264>]

Disclaimer & Data Validity:

The information provided in this document is for Research Use Only (RUO) and is strictly not intended for diagnostic or therapeutic procedures. While BenchChem strives to provide accurate protocols, we make no warranties, express or implied, regarding the fitness of this product for every specific experimental setup.

Technical Support: The protocols provided are for reference purposes. Unsure if this reagent suits your experiment?

Need Industrial/Bulk Grade? [Request Custom Synthesis Quote](#)

BenchChem

Our mission is to be the trusted global source of essential and advanced chemicals, empowering scientists and researchers to drive progress in science and industry.

Contact

Address: 3281 E Guasti Rd

Ontario, CA 91761, United States

Phone: (601) 213-4426

Email: info@benchchem.com

Contact our Ph.D. Support Team for a compatibility check