

The Biological Versatility of Pyrazole Derivatives: An In-depth Technical Guide

Author: BenchChem Technical Support Team. **Date:** April 2026

Compound of Interest

Compound Name: 3-Methylpyrazole

CAS No.: 88054-14-2

Cat. No.: B3431038

[Get Quote](#)

For Researchers, Scientists, and Drug Development Professionals

The pyrazole nucleus, a five-membered aromatic heterocycle with two adjacent nitrogen atoms, stands as a cornerstone in medicinal chemistry. Its derivatives have demonstrated a remarkable breadth of biological activities, leading to the development of several clinically significant drugs. This technical guide provides a comprehensive overview of the diverse pharmacological properties of pyrazole derivatives, with a focus on their anticancer, anti-inflammatory, antimicrobial, antiviral, and anticonvulsant activities. This document is intended to be a valuable resource for researchers and professionals involved in drug discovery and development, offering detailed experimental protocols, quantitative activity data, and visual representations of key signaling pathways and experimental workflows.

Anticancer Activity of Pyrazole Derivatives

Pyrazole derivatives have emerged as a promising class of anticancer agents, exhibiting cytotoxicity against a wide range of cancer cell lines. Their mechanisms of action are often centered on the inhibition of key protein kinases involved in cancer cell proliferation, survival, and angiogenesis.

Quantitative Anticancer Activity Data

The in vitro cytotoxic activity of various pyrazole derivatives is typically evaluated using the MTT assay, with results expressed as the half-maximal inhibitory concentration (IC₅₀). The following table summarizes the IC₅₀ values of selected pyrazole derivatives against various cancer cell lines.

Compound/Derivative	Cancer Cell Line	IC50 (μM)	Reference
Compound 1	MCF-7 (Breast)	0.042	[1]
PC3 (Prostate)	0.61	[1]	
A549 (Lung)	0.76	[1]	
Compound 2	HCT116 (Colon)	0.39	[2]
MCF-7 (Breast)	0.46	[2]	
Compound 3	WM266.4 (Melanoma)	0.12	
MCF-7 (Breast)	0.16		
Pyrazole Carbaldehyde Derivative	MCF-7 (Breast)	0.25	
Fused Pyrazole Derivative	HepG2 (Liver)	0.71	
Pyrazolopyrimidine Compound	HepG2 (Liver)	10.05	
MCF-7 (Breast)	17.12		
A549 (Lung)	29.95		
Pyrazolo[4,3- c]pyridine Derivative	MCF-7 (Breast)	1.937 (μg/mL)	
HepG2 (Liver)	3.695 (μg/mL)		
Selanyl-1H-pyrazole Derivative	HepG2 (Liver)	13.85	

Signaling Pathways in Cancer Targeted by Pyrazole Derivatives

The Epidermal Growth Factor Receptor (EGFR) and Vascular Endothelial Growth Factor Receptor 2 (VEGFR-2) are key tyrosine kinases that play crucial roles in tumor growth and angiogenesis. Many pyrazole derivatives have been designed to inhibit these receptors.

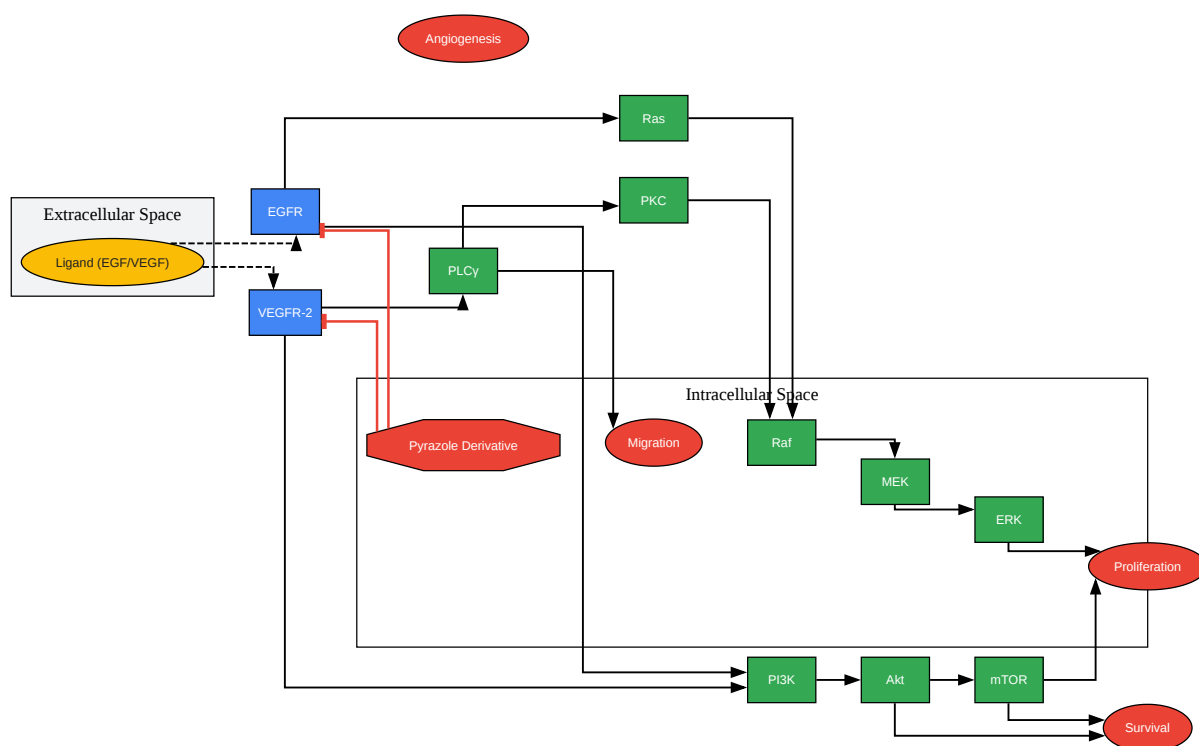

[Click to download full resolution via product page](#)

Inhibition of EGFR and VEGFR-2 Signaling by Pyrazole Derivatives.

Cyclin-dependent kinases (CDKs) are crucial for the regulation of the cell cycle. Dysregulation of CDK activity is a hallmark of cancer, making them attractive targets for anticancer therapies. Pyrazole derivatives have been shown to inhibit CDKs, leading to cell cycle arrest.

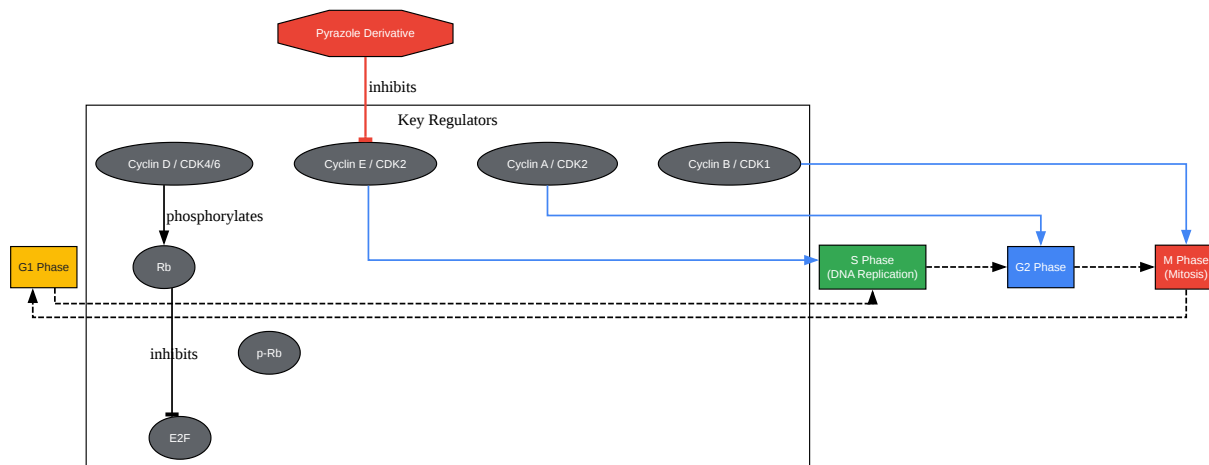

[Click to download full resolution via product page](#)

Pyrazole Derivatives Targeting CDK2 to Induce Cell Cycle Arrest.

Anti-inflammatory Activity of Pyrazole Derivatives

Many pyrazole derivatives exhibit potent anti-inflammatory properties, primarily through the inhibition of cyclooxygenase (COX) enzymes, which are key in the biosynthesis of prostaglandins. Some derivatives show selectivity for COX-2, the inducible isoform overexpressed at sites of inflammation, which can lead to a better safety profile compared to non-selective nonsteroidal anti-inflammatory drugs (NSAIDs).

Quantitative Anti-inflammatory Activity Data

The anti-inflammatory activity of pyrazole derivatives is often assessed by their ability to inhibit COX-1 and COX-2 enzymes in vitro (IC50 values) and to reduce paw edema in the in vivo carrageenan-induced paw edema model in rats (% inhibition).

Compound/ Derivative	COX-1 IC50 (μ M)	COX-2 IC50 (μ M)	Selectivity Index (COX- 1/COX-2)	Carrageena n-induced Paw Edema (% inhibition)	Reference
Celecoxib (Reference)	4.0	0.05	80	-	
3- (trifluorometh yl)-5- arylpyrazole	4.5	0.02	225	-	
Pyrazole- Thiazole Hybrid	-	0.03 (COX-2)	-	75%	
-	0.12 (5-LOX)				
3,5- diarylpyrazole	-	0.01	-	-	
Pyrazolo- pyrimidine	-	0.015	-	-	
N1- benzenesulfon amide Pyrazole	-	-	Preferential to COX-2	up to 90.40%	
Diaryl Pyrazole Derivative	0.263	0.017	15.47	-	
Benzenesulfo namide Pyrazole	-	0.039 (39.43 nM)	22.21	-	

NF- κ B Signaling Pathway in Inflammation

The nuclear factor-kappa B (NF- κ B) signaling pathway is a central mediator of inflammatory responses. It regulates the expression of pro-inflammatory genes, including cytokines and chemokines. Some pyrazole derivatives may exert their anti-inflammatory effects by modulating this pathway.

Modulation of the NF- κ B Inflammatory Pathway by Pyrazole Derivatives.

Antimicrobial Activity of Pyrazole Derivatives

Pyrazole derivatives have demonstrated significant activity against a variety of pathogenic microorganisms, including bacteria and fungi. Their mechanism of action can involve the inhibition of essential microbial enzymes or disruption of cell wall synthesis.

Quantitative Antimicrobial Activity Data

The antimicrobial efficacy of pyrazole derivatives is commonly determined by the Minimum Inhibitory Concentration (MIC), which is the lowest concentration of the compound that prevents visible growth of a microorganism.

Compound/Derivative	Microorganism	MIC ($\mu\text{g/mL}$)	Reference
Pyrazole-Thiazole Hybrid	Staphylococcus aureus (MRSA)	<0.2 (MBC)	
Imidazo-pyridine Substituted Pyrazole	E. coli, K. pneumoniae, P. aeruginosa	<1 (MBC)	
Triazine-fused Pyrazole	Staphylococcus epidermidis	0.97	
Enterobacter cloacae	0.48		
Thiazolidinone-clubbed Pyrazole	E. coli	16	
Pyrazole-1-carbothiohydrazide	S. aureus	62.5-125	
B. subtilis	62.5-125		
K. pneumoniae	62.5-125		
A. niger	2.9-7.8		
Pyrazole Derivative 3	E. coli	0.25	
Pyrazole Derivative 4	S. epidermidis	0.25	

Antiviral and Anticonvulsant Activities

Antiviral Activity

Certain pyrazole derivatives have shown promise as antiviral agents, with activity reported against a range of viruses. Their mechanisms can include the inhibition of viral replication enzymes or interference with viral entry into host cells.

Quantitative Antiviral Activity Data

Compound/Derivative	Virus	EC50	Reference
N-acetyl 4,5-dihydropyrazole	Vaccinia virus	7 µg/mL	
Aryl substituted pyrazole	HIV-1 (wild-type)	0.2 nM	
Pyrazole Derivative 412	Measles virus (MeV)	60 nM	
4-substituted 3-methyl-1,5-diphenyl-1H-pyrazole	Herpes simplex virus type-1	0.02 (IC50)	
Hydroxyquinoline-pyrazole Derivative	SARS-CoV-2	Promising selectivity	

Anticonvulsant Activity

The pyrazole scaffold is also found in compounds with anticonvulsant properties, which are evaluated in animal models of epilepsy.

Quantitative Anticonvulsant Activity Data

Compound/Derivative	Animal Model	ED50 (mg/kg)	Reference
Pyrazolyl Semicarbazone 6k	sc-PTZ (mice)	20.4	
Pyrazolone Derivative 11b	PTZ-induced seizures (mice)	Remarkable protection at 20 mg/kg	
Benzothiazole Pyrazole 6g	MES (mice)	-	
Benzothiazole Pyrazole 6m	MES (mice)	-	

Experimental Protocols

This section provides detailed methodologies for key experiments cited in this guide.

General Workflow for Biological Activity Screening

The evaluation of the biological activity of novel pyrazole derivatives typically follows a structured workflow, from initial screening to more detailed mechanistic studies.

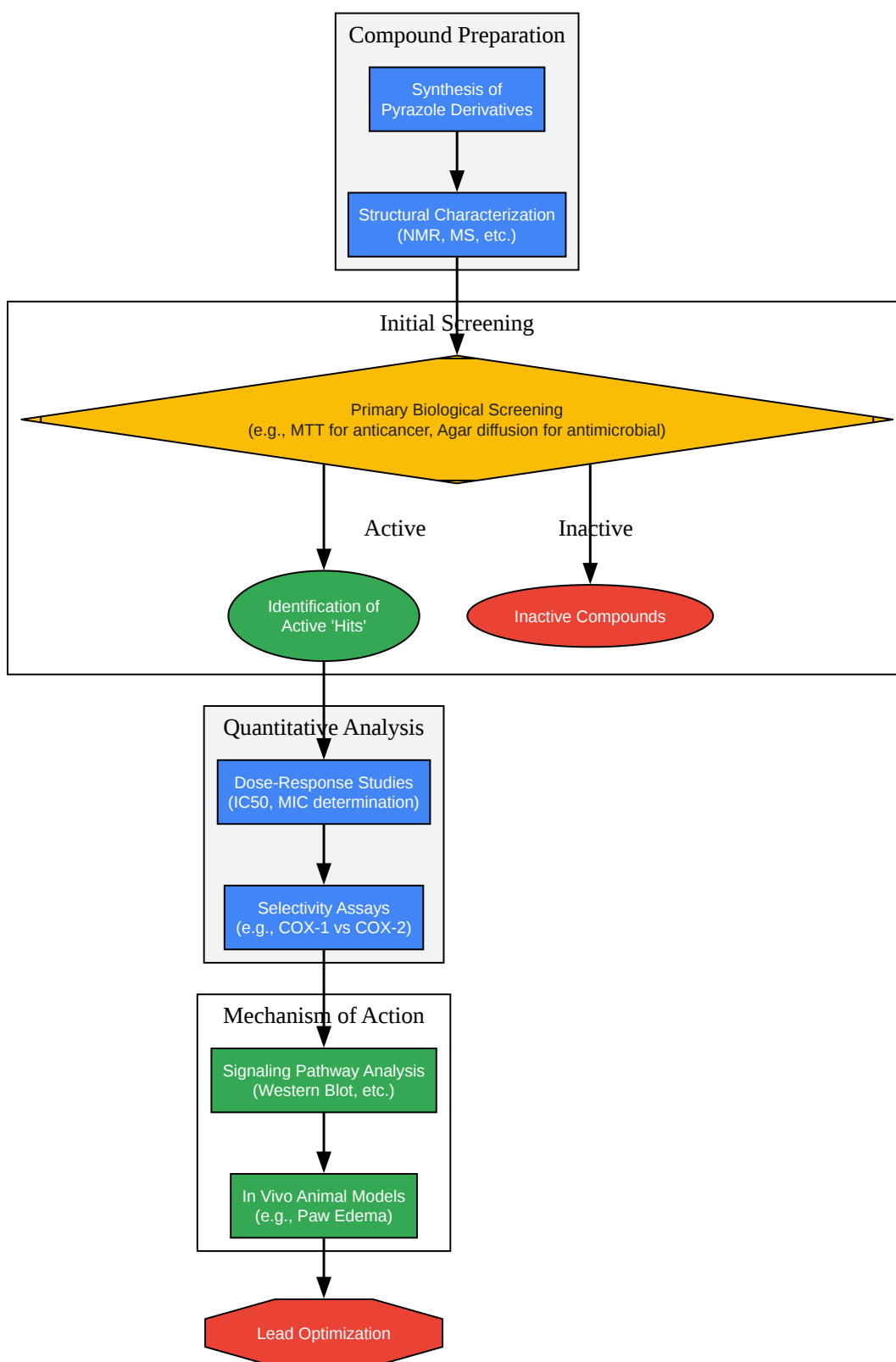

[Click to download full resolution via product page](#)

General Experimental Workflow for Evaluating Pyrazole Derivatives.

Detailed Protocol for MTT Assay (Anticancer)

Principle: The 3-(4,5-dimethylthiazol-2-yl)-2,5-diphenyltetrazolium bromide (MTT) assay is a colorimetric assay for assessing cell metabolic activity. NAD(P)H-dependent cellular oxidoreductase enzymes in viable cells reduce the yellow MTT to purple formazan crystals.

Procedure:

- **Cell Seeding:** Seed cancer cells in a 96-well plate at a density of 5,000-10,000 cells/well and incubate for 24 hours to allow for cell attachment.
- **Compound Treatment:** Treat the cells with various concentrations of the pyrazole derivatives (typically in a serial dilution) and incubate for 48-72 hours. Include a vehicle control (e.g., DMSO) and a positive control (a known anticancer drug).
- **MTT Addition:** Add 20 μ L of MTT solution (5 mg/mL in PBS) to each well and incubate for 4 hours at 37°C.
- **Formazan Solubilization:** Carefully remove the medium and add 150 μ L of DMSO to each well to dissolve the formazan crystals.
- **Absorbance Measurement:** Measure the absorbance at 570 nm using a microplate reader.
- **Data Analysis:** Calculate the percentage of cell viability relative to the vehicle control and determine the IC₅₀ value by plotting a dose-response curve.

Detailed Protocol for Carrageenan-Induced Paw Edema Assay (Anti-inflammatory)

Principle: This in vivo assay evaluates the anti-inflammatory activity of a compound by measuring its ability to reduce the edema (swelling) induced by the injection of carrageenan, an inflammatory agent, into the paw of a rodent.

Procedure:

- **Animal Acclimatization:** Acclimatize male Wistar rats or Swiss albino mice for at least one week before the experiment.

- **Compound Administration:** Administer the pyrazole derivative orally or intraperitoneally to the test group of animals. The control group receives the vehicle, and a positive control group receives a standard anti-inflammatory drug (e.g., indomethacin).
- **Induction of Edema:** After a specific time (e.g., 30-60 minutes) following compound administration, inject 0.1 mL of a 1% carrageenan solution in saline into the sub-plantar region of the right hind paw of each animal.
- **Paw Volume Measurement:** Measure the paw volume of each animal using a plethysmometer at 0, 1, 2, 3, and 4 hours after the carrageenan injection.
- **Data Analysis:** Calculate the percentage of inhibition of edema for each group compared to the control group.

Detailed Protocol for In Vitro COX-1 and COX-2 Inhibition Assay

Principle: This assay measures the ability of a compound to inhibit the activity of the COX-1 and COX-2 enzymes, typically by quantifying the production of prostaglandins from arachidonic acid.

Procedure:

- **Enzyme and Substrate Preparation:** Prepare solutions of purified ovine COX-1 and human recombinant COX-2 enzymes, and a solution of the substrate, arachidonic acid.
- **Compound Incubation:** In a 96-well plate, incubate the enzymes with various concentrations of the pyrazole derivatives for a short period (e.g., 15 minutes) at 37°C.
- **Reaction Initiation:** Initiate the enzymatic reaction by adding arachidonic acid to each well.
- **Reaction Termination:** Stop the reaction after a specific time (e.g., 10 minutes) by adding a stopping reagent (e.g., HCl).
- **Prostaglandin Quantification:** Quantify the amount of prostaglandin E2 (PGE2) produced using an Enzyme-Linked Immunosorbent Assay (ELISA) kit.

- **Data Analysis:** Calculate the percentage of COX inhibition for each concentration of the test compound and determine the IC50 values for both COX-1 and COX-2.

Detailed Protocol for Broth Microdilution MIC Assay (Antimicrobial)

Principle: The broth microdilution method is a quantitative assay used to determine the minimum inhibitory concentration (MIC) of an antimicrobial agent against a specific microorganism in a liquid medium.

Procedure:

- **Inoculum Preparation:** Prepare a standardized suspension of the test microorganism (bacteria or fungi) in a suitable broth medium, adjusted to a 0.5 McFarland standard.
- **Serial Dilution:** In a 96-well microtiter plate, perform a serial two-fold dilution of the pyrazole derivative in the broth medium.
- **Inoculation:** Inoculate each well with the standardized microbial suspension. Include a growth control well (no compound) and a sterility control well (no inoculum).
- **Incubation:** Incubate the plate at an appropriate temperature (e.g., 37°C for bacteria, 28°C for fungi) for 18-24 hours (bacteria) or 48-72 hours (fungi).
- **MIC Determination:** The MIC is the lowest concentration of the compound at which there is no visible growth of the microorganism.

Detailed Protocol for Plaque Reduction Assay (Antiviral)

Principle: This assay quantifies the ability of a compound to inhibit the replication of a lytic virus by measuring the reduction in the number of plaques (zones of cell death) formed in a monolayer of host cells.

Procedure:

- **Cell Seeding:** Seed a confluent monolayer of susceptible host cells in a multi-well plate.

- **Virus and Compound Preparation:** Prepare serial dilutions of the pyrazole derivative and a standardized dilution of the virus stock.
- **Infection:** Infect the cell monolayer with the virus in the presence of the different concentrations of the pyrazole derivative.
- **Overlay:** After an adsorption period, remove the inoculum and add a semi-solid overlay (e.g., containing agarose or methylcellulose) to restrict the spread of the virus.
- **Incubation:** Incubate the plates for a period sufficient for plaque formation (typically 2-10 days).
- **Plaque Visualization:** Fix the cells and stain them with a dye (e.g., crystal violet). Plaques will appear as clear zones against a background of stained, uninfected cells.
- **Data Analysis:** Count the number of plaques in each well and calculate the percentage of plaque reduction compared to the virus control (no compound). Determine the EC50 value.

Conclusion

The pyrazole scaffold continues to be a highly privileged structure in the field of medicinal chemistry, yielding derivatives with a wide array of potent biological activities. The information presented in this technical guide, including quantitative data, detailed experimental protocols, and visualizations of key molecular pathways, is intended to serve as a valuable resource for researchers dedicated to the discovery and development of novel pyrazole-based therapeutic agents. The versatility of the pyrazole ring system, coupled with an ever-expanding understanding of its structure-activity relationships, ensures its continued importance in the quest for new and improved treatments for a multitude of diseases.

Need Custom Synthesis?

BenchChem offers custom synthesis for rare earth carbides and specific isotopic labeling.

Email: info@benchchem.com or [Request Quote Online](#).

References

- [1. Recent Advancement in Drug Design and Discovery of Pyrazole Biomolecules as Cancer and Inflammation Therapeutics - PMC \[pmc.ncbi.nlm.nih.gov\]](#)
- [2. encyclopedia.pub \[encyclopedia.pub\]](#)
- To cite this document: BenchChem. [The Biological Versatility of Pyrazole Derivatives: An In-depth Technical Guide]. BenchChem, [2026]. [Online PDF]. Available at: [\[https://www.benchchem.com/product/b3431038/docs#the-biological-versatility-of-pyrazole-derivatives-an-in-depth-technical-guide\]](https://www.benchchem.com/product/b3431038/docs#the-biological-versatility-of-pyrazole-derivatives-an-in-depth-technical-guide)

Disclaimer & Data Validity:

The information provided in this document is for Research Use Only (RUO) and is strictly not intended for diagnostic or therapeutic procedures. While BenchChem strives to provide accurate protocols, we make no warranties, express or implied, regarding the fitness of this product for every specific experimental setup.

Technical Support: The protocols provided are for reference purposes. Unsure if this reagent suits your experiment?

Need Industrial/Bulk Grade? [Request Custom Synthesis Quote](#)

BenchChem

Our mission is to be the trusted global source of essential and advanced chemicals, empowering scientists and researchers to drive progress in science and industry.

Contact

Address: 3281 E Guasti Rd
Ontario, CA 91761, United States
Phone: (601) 213-4426
Email: info@benchchem.com

[Contact our Ph.D. Support Team for a compatibility check](#)

