

# Application Notes & Protocols: High-Yield Santalol Extraction

**Author:** BenchChem Technical Support Team. **Date:** April 2026

## Compound of Interest

Compound Name:	Santalol
CAS No.:	73890-74-1
Cat. No.:	B3429334

[Get Quote](#)

## Introduction

**Santalol**, primarily its isomers  $\alpha$ -**santalol** and  $\beta$ -**santalol**, is the main sesquiterpene alcohol responsible for the characteristic woody and sweet fragrance of sandalwood oil. This prized essential oil is extracted from the heartwood of trees from the *Santalum* genus, most notably *Santalum album* (Indian sandalwood). Beyond its extensive use in perfumery and cosmetics, **santalol** exhibits various potential medicinal properties, including anti-inflammatory, antioxidant, and anti-cancer activities, making it a compound of significant interest for researchers and drug development professionals.<sup>[1]</sup> The quality and commercial value of sandalwood oil are largely determined by the concentration of  $\alpha$ - and  $\beta$ -**santalol**.<sup>[2]</sup> According to ISO 3518:2002 standards, high-quality *S. album* oil should contain 41–55%  $\alpha$ -**santalol** and 16–24%  $\beta$ -**santalol**.<sup>[3][4]</sup>

The high demand and over-harvesting of sandalwood trees necessitate the development of highly efficient extraction methods to maximize the yield of **santalol** from the raw plant material. This document provides detailed application notes and protocols for various solvent extraction techniques aimed at achieving a high **santalol** yield, intended for researchers, scientists, and professionals in the field.

## Extraction Methodologies Overview

Several extraction techniques, ranging from traditional to modern, can be employed to isolate sandalwood oil. The choice of method significantly impacts the oil yield, **santalol** concentration, overall chemical profile, and extraction time.

- **Subcritical/Supercritical Fluid Extraction (SFE):** This technique uses carbon dioxide (CO<sub>2</sub>) in its subcritical or supercritical state as a solvent. It is considered a "green" technology as CO<sub>2</sub> is non-toxic, non-flammable, and easily removed from the final product. SFE is known for its high efficiency and ability to extract thermosensitive compounds with minimal degradation.[3][5] Subcritical CO<sub>2</sub> extraction, performed at lower temperatures and pressures, has shown remarkable results for sandalwood oil, yielding high **santalol** content.[6][7]
- **Soxhlet Extraction:** A classic and continuous solvent extraction method, Soxhlet extraction uses organic solvents like ethanol, hexane, toluene, or benzene.[5][8] While effective, it requires relatively long extraction times and subsequent removal of the solvent, which can leave trace residues if not performed meticulously.[9]
- **Microwave-Assisted Hydrodistillation (MAHD):** This modern technique utilizes microwave energy to heat the water and plant material, accelerating the extraction process.[9] It significantly reduces extraction time and energy consumption compared to conventional distillation methods.[10][11] A variation, Microwave Air-Hydrodistillation, can further enhance the speed and yield.[10]
- **Ultrasound-Assisted Extraction (UAE):** UAE employs high-frequency sound waves to create cavitation bubbles in the solvent. The collapse of these bubbles near the plant cell walls causes disruption, enhancing solvent penetration and mass transfer.[12][13] This method reduces extraction time and can increase yield, often used in conjunction with other techniques.[12]
- **Conventional Methods (for comparison):**
  - **Steam Distillation:** A traditional method where steam is passed through the plant material, vaporizing the volatile compounds, which are then condensed and collected.[5][8]
  - **Hydrodistillation:** The plant material is boiled in water, and the resulting steam carrying the essential oil is condensed and collected.[5]

## Data Presentation: Comparative Analysis of Extraction Methods

The following tables summarize quantitative data from various studies, comparing the efficacy of different extraction methods based on oil yield and **santalol** content.

Table 1: Oil Yield and Extraction Time

Extraction Method	Oil Yield	Extraction Time	Source
Subcritical CO <sub>2</sub> Extraction	4.11% (in 1st hour)	1-4 hours	[5]
Subcritical CO <sub>2</sub> Extraction	3.83 g/L	Not Specified	[6][7]
Soxhlet (Ethanol)	3.70% (absolute)	5 hours	[5]
Soxhlet (Benzene)	3.01% (absolute)	5 hours	[5]
Soxhlet (Diethyl Ether)	2.58% (absolute)	5 hours	[5]
Microwave Air-Hydrodistillation	1.32%	40-50 minutes	[10]
Microwave Hydrodistillation	1.22%	120 minutes	[10]
Steam Distillation	1.60%	10 hours	[5]
Steam Distillation (Clevenger)	1.15% - 2.88%	20-24 hours	[8]
Hydrodistillation (Alkaline Treated)	2.68%	48 hours	[5]
Hydrodistillation	1.56%	38 hours	[5]

Table 2: **Santalol** Content (% of Total Oil)

Extraction Method	$\alpha$ -santalol (%)	$\beta$ -santalol (%)	Total Santalol (%)	Source
Subcritical CO <sub>2</sub> Extraction	51.30 - 54.50	26.18 - 28.16	~77.5 - 82.6	[5]
Subcritical CO <sub>2</sub> Extraction	Not Specified	Not Specified	~83	[6][7]
Soxhlet (Ethanol)	Not Specified	Not Specified	~84	[6][7]
Soxhlet (Benzene)	38.21	22.96	61.17	[5]
Soxhlet (Toluene)	39.71	19.76	59.47	[5]
Microwave Hydrodistillation	28.73	24.10	52.83	[9]
Steam Distillation	54.65 - 55.14	22.58 - 25.72	~77.3 - 80.4	[8]
Steam Distillation	42.22	23.26	65.48	[5]
Steam Distillation	Not Specified	Not Specified	~84	[6][7]
Hydrodistillation	56.73	27.10	83.83	[5]

## Experimental Protocols

### Protocol 1: Subcritical Carbon Dioxide (SC-CO<sub>2</sub>) Extraction

This protocol is based on the conditions described for high-yield extraction of sandalwood oil.

[5][6]

Materials and Equipment:

- Supercritical Fluid Extraction (SFE) system with an extractor and separator vessel
- High-pressure pump
- Heater/Chiller for temperature control

- Back-pressure regulator
- Liquid CO<sub>2</sub> source (99.9% purity)[2]
- Pulverized sandalwood heartwood (e.g., 40 mm particle size)[5]
- Collection vials

#### Procedure:

- Preparation: Pulverize dried sandalwood chips to the desired particle size.
- Loading: Load the powdered sandalwood into the SFE's extraction vessel.
- System Setup:
  - Set the extractor temperature to 28°C.
  - Set the system pressure to 200 bar.[5]
- Extraction:
  - Introduce liquid CO<sub>2</sub> into the system using the high-pressure pump.
  - Allow the CO<sub>2</sub> to reach the subcritical state within the extractor under the set conditions.
  - Begin the extraction process, allowing the subcritical CO<sub>2</sub> to flow through the sandalwood powder. The CO<sub>2</sub> acts as a solvent, dissolving the essential oil.
- Separation and Collection:
  - The CO<sub>2</sub> laden with the extracted oil flows into the separator vessel.
  - In the separator, reduce the pressure to allow the CO<sub>2</sub> to return to its gaseous state, causing the sandalwood oil to precipitate.
  - Collect the extracted oil from the bottom of the separator. For kinetic studies, collect fractions at set intervals (e.g., every hour for 4 hours).[5]

- Analysis: Analyze the collected oil fractions for yield and composition ( $\alpha$ - and  $\beta$ -**santalol** content) using Gas Chromatography (GC) or Gas Chromatography-Mass Spectrometry (GC-MS).

#### Protocol 2: Soxhlet Extraction

This protocol outlines a general procedure for solvent extraction using a Soxhlet apparatus, adaptable for various solvents like ethanol, hexane, or toluene.[8][14]

#### Materials and Equipment:

- Soxhlet apparatus (round-bottom flask, extractor, condenser)
- Heating mantle
- Cellulose extraction thimble
- Selected solvent (e.g., 95% Ethanol, Hexane, Toluene)[8]
- Powdered sandalwood heartwood
- Rotary evaporator
- Glass wool

#### Procedure:

- Preparation: Place a small plug of glass wool at the bottom of the extraction thimble and fill it with a known weight of powdered sandalwood.
- Apparatus Setup:
  - Place the thimble inside the Soxhlet extractor.
  - Fill the round-bottom flask to about two-thirds of its volume with the chosen solvent.
  - Assemble the apparatus by connecting the flask to the extractor and the condenser above it. Secure all joints.

- Extraction:
  - Heat the flask using the heating mantle. The solvent will boil, and its vapor will travel up the distillation arm into the condenser.
  - The condensed solvent will drip into the thimble, immersing the sandalwood powder and extracting the oil.
  - Once the solvent level reaches the top of the siphon tube, the entire volume of solvent and extracted oil will be siphoned back into the flask.
  - Allow this cycle to repeat continuously for a set duration (e.g., 5-16 hours).[\[2\]](#)[\[5\]](#)
- Solvent Removal:
  - After the extraction is complete, turn off the heat and allow the apparatus to cool.
  - Dismantle the setup and transfer the solvent containing the extracted oil to a rotary evaporator.
  - Remove the solvent under reduced pressure to obtain the crude sandalwood oil (concrete or absolute).
- Analysis: Determine the yield and analyze the **santalol** content of the extract using GC-MS.

### Protocol 3: Microwave-Assisted Hydrodistillation (MAHD)

This protocol is based on MAHD methods used for extracting essential oils from plant materials.[\[9\]](#)[\[10\]](#)[\[15\]](#)

#### Materials and Equipment:

- Modified microwave oven designed for extraction
- Distillation flask with a Clevenger-type apparatus
- Condenser

- Powdered sandalwood heartwood
- Distilled water

#### Procedure:

- Preparation: Place a known quantity of powdered sandalwood into the distillation flask.
- Apparatus Setup:
  - Add distilled water to the flask to achieve a specific material-to-solvent ratio (e.g., 0.05 g/mL).[10][15]
  - Connect the flask to the Clevenger apparatus and condenser. Place the entire setup inside the microwave cavity.
- Extraction:
  - Set the microwave power to the desired level (e.g., 600W).[10][15]
  - Begin the extraction process. The microwave radiation will rapidly heat the water, generating internal steam that ruptures the plant cells and carries the volatile oil.
  - The steam and oil vapor mixture will rise, cool in the condenser, and collect in the graduated tube of the Clevenger apparatus.
  - Continue the process for the specified duration (e.g., 120 minutes).[9]
- Collection:
  - Once the extraction is complete, turn off the microwave and allow the apparatus to cool.
  - Carefully collect the separated oil layer from the Clevenger apparatus.
- Analysis: Dry the oil (e.g., over anhydrous sodium sulfate) and analyze its yield and chemical composition via GC-MS.[8]

## Visualizations: Experimental Workflows

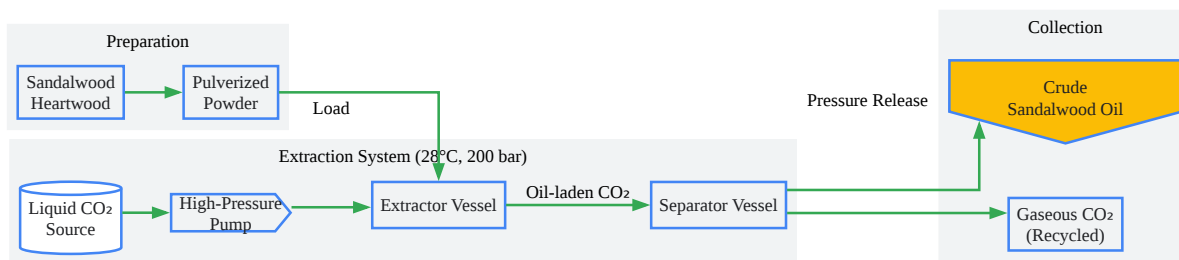

[Click to download full resolution via product page](#)

Caption: Workflow for Subcritical CO<sub>2</sub> Extraction of **Santalol**.

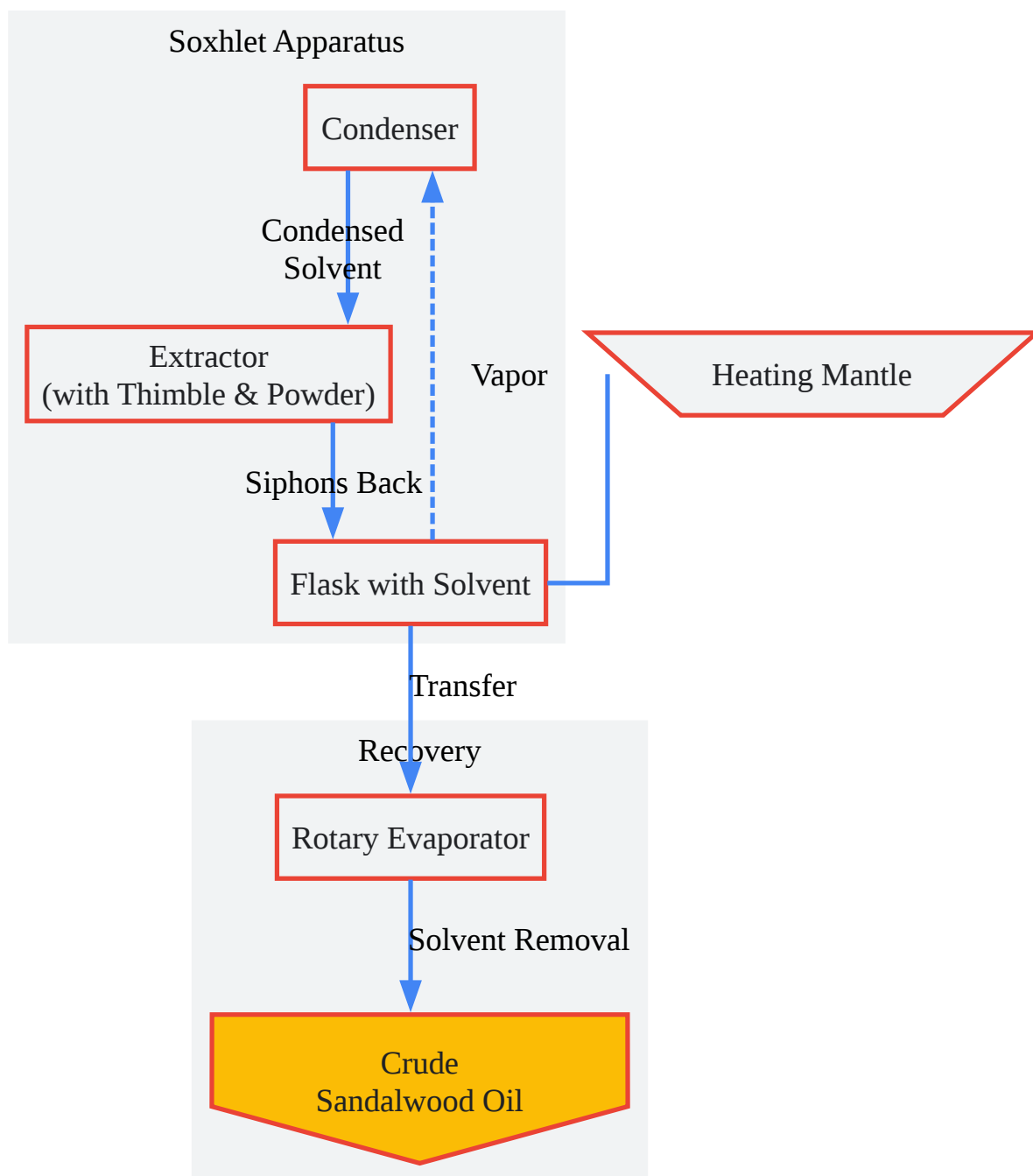

[Click to download full resolution via product page](#)

Caption: Workflow for Soxhlet Extraction of **Santalol**.

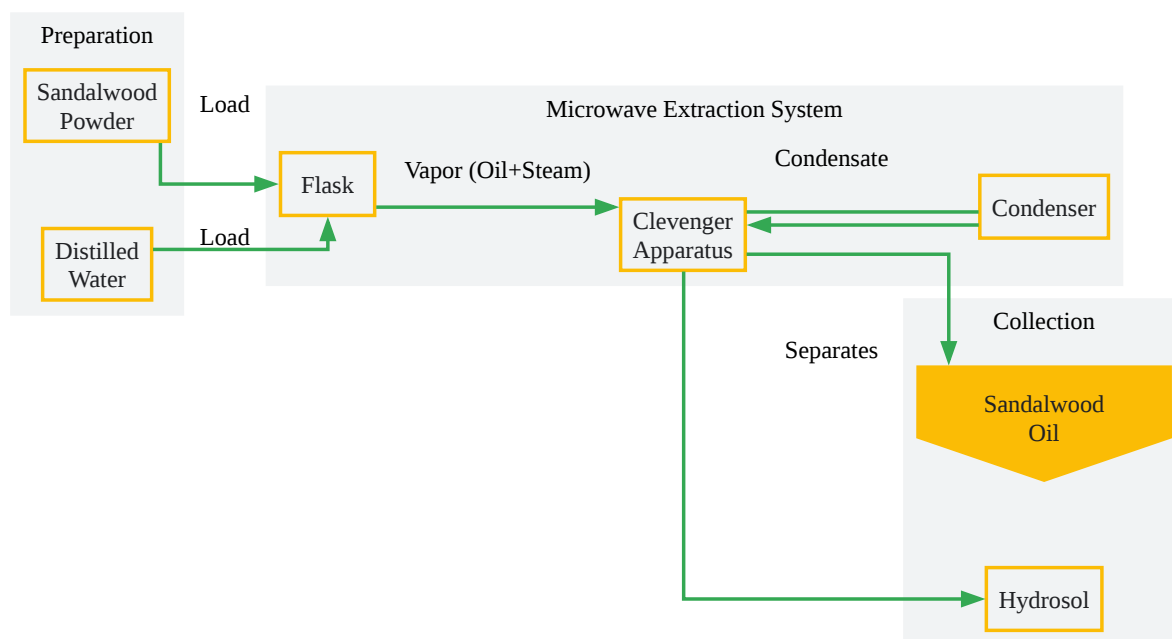

[Click to download full resolution via product page](#)

Caption: Workflow for Microwave-Assisted Hydrodistillation.

### Need Custom Synthesis?

BenchChem offers custom synthesis for rare earth carbides and specific isotopic labeling.

Email: [info@benchchem.com](mailto:info@benchchem.com) or [Request Quote Online](#).

## References

- 1. [dc.etsu.edu](http://dc.etsu.edu) [[dc.etsu.edu](http://dc.etsu.edu)]
- 2. [sandalwood-australia.com.au](http://sandalwood-australia.com.au) [[sandalwood-australia.com.au](http://sandalwood-australia.com.au)]

- [3. kingsresearch.com \[kingsresearch.com\]](https://kingsresearch.com)
- [4. researchgate.net \[researchgate.net\]](https://researchgate.net)
- [5. nopr.niscpr.res.in \[nopr.niscpr.res.in\]](https://nopr.niscpr.res.in)
- [6. researchgate.net \[researchgate.net\]](https://researchgate.net)
- [7. discovery.researcher.life \[discovery.researcher.life\]](https://discovery.researcher.life)
- [8. Digital Commons @ East Tennessee State University - Dr. Jay W. Boland Undergraduate Research Symposium \[2023-2024\]: Extraction of Sandalwood Essential Oil: Isolating  \$\alpha/\beta\$ -Santalol \[dc.etsu.edu\]](https://dc.etsu.edu)
- [9. pubs.aip.org \[pubs.aip.org\]](https://pubs.aip.org)
- [10. jmaterenvironsci.com \[jmaterenvironsci.com\]](https://jmaterenvironsci.com)
- [11. scholar.its.ac.id \[scholar.its.ac.id\]](https://scholar.its.ac.id)
- [12. foodsciencejournal.com \[foodsciencejournal.com\]](https://foodsciencejournal.com)
- [13. mdpi.com \[mdpi.com\]](https://mdpi.com)
- [14. rjpn.org \[rjpn.org\]](https://rjpn.org)
- [15. researchgate.net \[researchgate.net\]](https://researchgate.net)
- To cite this document: BenchChem. [Application Notes & Protocols: High-Yield Santalol Extraction]. BenchChem, [2026]. [Online PDF]. Available at: [\[https://www.benchchem.com/product/b3429334/docs#application-notes-protocols-high-yield-santalol-extraction\]](https://www.benchchem.com/product/b3429334/docs#application-notes-protocols-high-yield-santalol-extraction)

---

### Disclaimer & Data Validity:

The information provided in this document is for Research Use Only (RUO) and is strictly not intended for diagnostic or therapeutic procedures. While BenchChem strives to provide accurate protocols, we make no warranties, express or implied, regarding the fitness of this product for every specific experimental setup.

**Technical Support:** The protocols provided are for reference purposes. Unsure if this reagent suits your experiment?

**Need Industrial/Bulk Grade?** [Request Custom Synthesis Quote](#)

# BenchChem

Our mission is to be the trusted global source of essential and advanced chemicals, empowering scientists and researchers to drive progress in science and industry.

## Contact

Address: 3281 E Guasti Rd

Ontario, CA 91761, United States

Phone: (601) 213-4426

Email: [info@benchchem.com](mailto:info@benchchem.com)

[Contact our Ph.D. Support Team for a compatibility check](#)