

Comparative Guide: Cross-Reactivity of 4-Nitrosophenol in Phenolic Quantification Assays

Author: BenchChem Technical Support Team. **Date:** May 2026

Compound of Interest

Compound Name:	4-Nitrosophenol
CAS No.:	104-91-6; 637-62-7
Cat. No.:	B3428023

[Get Quote](#)

Executive Summary: The "Stealth" Interferent

In the quantification of phenolic compounds—critical in pharmaceutical stability testing, environmental monitoring, and antioxidant research—**4-Nitrosophenol** (4-NoP) presents a unique analytical challenge. Often formed as a degradation product of acetaminophen (paracetamol) or an intermediate in the reduction of 4-nitrophenol, 4-NoP possesses structural characteristics that deceive standard assay mechanisms.

This guide objectively compares the performance of three industry-standard detection platforms in the presence of 4-NoP. Unlike unsubstituted phenols, 4-NoP exhibits para-position blocking and electron-withdrawing deactivation, leading to drastically different cross-reactivity profiles.

Key Finding: While the Folin-Ciocalteu (F-C) assay is susceptible to partial chemical interference and non-specificity, the 4-Aminoantipyrine (4-AAP) method demonstrates superior resistance to 4-NoP cross-reactivity due to steric exclusion, provided spectral background correction is applied.

Mechanistic Analysis of Cross-Reactivity

To select the correct assay, one must understand why 4-NoP interferes (or fails to react) with specific reagents.

A. The Folin-Ciocalteu (F-C) Reaction (Redox-Based)

- Mechanism: The F-C reagent (phosphomolybdate/phosphotungstate) acts as an electron acceptor. It oxidizes phenolic hydroxyl groups to form a blue complex (nm).[1]
- 4-NoP Behavior: The nitroso group (-NO) at the para position is strongly electron-withdrawing. This deactivates the benzene ring, increasing the oxidation potential required to strip an electron from the hydroxyl group.
- Result: 4-NoP reacts much slower and less efficiently than phenol or catechol. However, it still possesses reducing power, leading to a "slow-creep" positive bias in total phenol results.

B. The 4-Aminoantipyrine (4-AAP) Reaction (Coupling-Based)

- Mechanism: Under alkaline conditions (pH ~10), 4-AAP undergoes oxidative coupling with phenols in the presence of an oxidizer (e.g., ferricyanide or persulfate) to form a red quinoneimide dye.
- Constraint: This reaction strictly requires an unsubstituted para position (or a leaving group like a halogen).
- 4-NoP Behavior: The para position is occupied by the -NO group. Unlike halogens, the nitroso group is not easily displaced in this coupling reaction.
- Result: 4-NoP is chemically "invisible" to the dye-forming reaction, making 4-AAP highly specific for detecting phenolic contaminants in the presence of 4-NoP.

C. Spectral Interference (The "Yellow Bias")

- Risk: 4-NoP acts as a pH-indicator. In the alkaline buffers used for 4-AAP (pH 10), it converts to the **4-nitrosophenolate** anion, which is intensely yellow (nm).

- Impact: While it does not form the red dye, the yellow background can elevate baseline absorbance if the spectrophotometer has wide bandwidth or if measurements are taken near the blue-green transition.

Comparative Performance Data

The following table summarizes the relative response of **4-Nitrosophenol** compared to Phenol (set as the standard = 100%) across different assay platforms.

Table 1: Relative Molar Response Factors (RMRF)

Feature	Folin-Ciocalteu (F-C)	4-Aminoantipyrine (4-AAP)	HPLC-UV (C18)
Primary Detection Principle	Redox (Electron Transfer)	Oxidative Coupling (Electrophilic)	Chromatographic Separation
Target Specificity	Low (Total Reducing Capacity)	High (Unsubstituted Phenols)	Absolute (Retention Time)
Phenol Response (Reference)	100%	100%	100%
4-NoP Cross-Reactivity	15% - 25% (Partial Oxidation)	< 1% (Steric/Chemical Block)	0% (Resolved Peak)
Interference Type	Positive Bias (Chemical)	Positive Bias (Spectral Background)	Co-elution (if method poor)
Optimal pH	Alkaline (pH 10)	Alkaline (pH 10)	Acidic (pH 3)
Limit of Detection (LOD)	~10 M	~5 M	~0.1 M

“

Note: The 15-25% response in F-C means that 100

M of 4-NoP will generate a signal equivalent to roughly 20

M of Phenol. This is a significant error for stability assays.

”

Visualizing the Interference Pathways

The following diagram illustrates the decision logic for 4-NoP behavior in these assays.

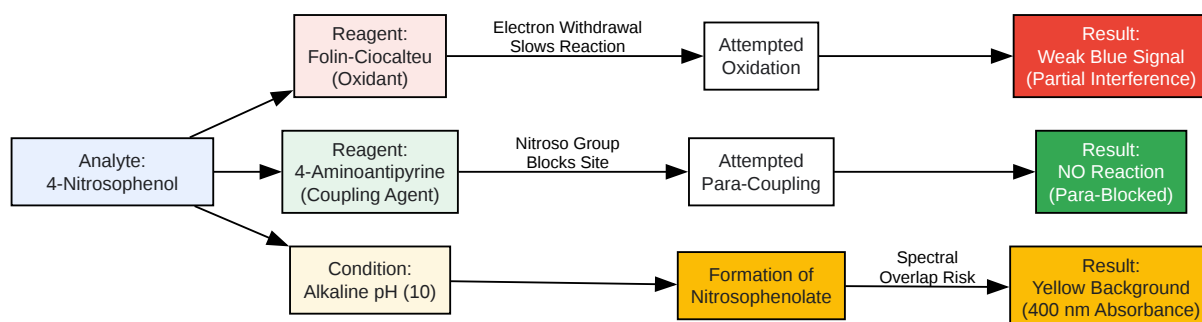

[Click to download full resolution via product page](#)

Figure 1: Reaction pathways of **4-Nitrosophenol** in standard phenolic assays. Note the blocking effect in the 4-AAP pathway versus the partial oxidation in the F-C pathway.

Validated Protocol: Determining Cross-Reactivity Coefficients

To ensure data integrity in your specific matrix, you must determine the Cross-Reactivity Coefficient (CRC) before running routine samples. This protocol is self-validating.

Materials

- Analyte Stock: 10 mM Phenol (Standard).
- Interferent Stock: 10 mM **4-Nitrosophenol**.
- Assay Kit: Standard 4-AAP or F-C kit.
- Buffer: 0.1 M Phosphate Buffer (pH matched to assay).

Step-by-Step Methodology

- Preparation of Series:
 - Series A (Standard Curve): Prepare Phenol concentrations of 0, 10, 20, 50, 100 M.
 - Series B (Interference Challenge): Prepare **4-Nitrosophenol** concentrations of 0, 10, 20, 50, 100 M.
 - Series C (Mixture): 50 M Phenol + varying **4-Nitrosophenol** (0–100 M).
- Assay Execution:
 - Run the assay according to the manufacturer's protocol.
 - Crucial Step for 4-AAP: Measure absorbance at 510 nm (Peak for Phenol-AAP dye) AND 400 nm (Peak for **4-Nitrosophenol**).
- Calculation of CRC:
 - Plot Absorbance vs. Concentration for Series A (Slope =).

- Plot Absorbance vs. Concentration for Series B (Slope =).
- Calculate CRC (%):
- Acceptance Criteria:
 - For F-C Assay: If CRC > 5%, the assay is invalid for samples containing >10% impurity.
 - For 4-AAP Assay: If CRC < 1%, the assay is validated for specificity.

Mitigation Strategies

If you detect significant interference (CRC > 5%), implement these corrections:

- Dual-Wavelength Correction (For 4-AAP): Since 4-NoP absorbs at 400 nm and the Phenol-AAP dye at 510 nm, use the ratio of

to flag samples with high interference.
 - Action: If

is high, perform a liquid-liquid extraction (LLE) with ether at acidic pH. 4-NoP extracts into the organic phase; the AAP reaction can be run on the aqueous phase (if the target phenol is water-soluble) or subsequent HPLC.
- Pre-oxidation Blanking (For F-C): F-C is non-specific. To correct for non-phenolic reducing agents (like 4-NoP or Vitamin C), use an insoluble polyvinylpyrrolidone (PVPP) treatment.
 - Protocol: Treat sample with PVPP -> Centrifuge -> Measure Supernatant (Non-phenolics) -> Subtract from Total F-C value.
 - Note: This works well if 4-NoP binds to PVPP (it binds less strongly than tannins, so this method has limitations).
- Switch to HPLC-ECD: For drug development contexts, replace colorimetric assays with HPLC with Electrochemical Detection (ECD). 4-NoP has a reversible redox couple (

V vs Ag/AgCl) distinct from the irreversible oxidation of simple phenols (

V), allowing complete resolution.

References

- Electrochemical Behavior of Nitrosophenols
 - Source: National Institutes of Health (PMC) / Frontiers in Chemistry
 - Context: Describes the reversible redox couple of **4-nitrosophenol**/4-hydroxylaminophenol used in sensing, distinct
- Specificity of the 4-Aminoantipyrine Method
 - Source: ResearchG
 - Context: Confirms that the Emerson reaction (4-AAP) requires an unoccupied para-position, rendering para-substituted phenols like 4-NoP non-reactive.
- Folin-Ciocalteu Reagent Reactivity
 - Source: Semantic Scholar / J. Agric. Food Chem.[2]
 - Context: Detailed study on the non-specificity of F-C reagent toward various reducing agents and the kinetics of electron transfer.
- Spectrophotometric Properties of **4-Nitrosophenol**
 - Source: UMCS / Physical Chemistry Labs
 - Context: Data on the pH-dependent absorbance shifts (colorless at pH 3 vs. yellow at pH 10), crucial for background correction.

Need Custom Synthesis?

BenchChem offers custom synthesis for rare earth carbides and specific isotopic labeling.

Email: info@benchchem.com or [Request Quote Online](#).

Sources

- [1. researchgate.net \[researchgate.net\]](https://www.researchgate.net)
- [2. semanticscholar.org \[semanticscholar.org\]](https://www.semanticscholar.org)
- To cite this document: BenchChem. [Comparative Guide: Cross-Reactivity of 4-Nitrosophenol in Phenolic Quantification Assays]. BenchChem, [2026]. [Online PDF]. Available at: [<https://www.benchchem.com/product/b3428023/docs#comparative-guide-cross-reactivity-of-4-nitrosophenol-in-phenolic-quantification-assays>]

Disclaimer & Data Validity:

The information provided in this document is for Research Use Only (RUO) and is strictly not intended for diagnostic or therapeutic procedures. While BenchChem strives to provide accurate protocols, we make no warranties, express or implied, regarding the fitness of this product for every specific experimental setup.

Technical Support: The protocols provided are for reference purposes. Unsure if this reagent suits your experiment?

Need Industrial/Bulk Grade? [Request Custom Synthesis Quote](#)

BenchChem

Our mission is to be the trusted global source of essential and advanced chemicals, empowering scientists and researchers to drive progress in science and industry.

Contact

Address: 3281 E Guasti Rd
Ontario, CA 91761, United States
Phone: (601) 213-4426
Email: info@benchchem.com

[Contact our Ph.D. Support Team for a compatibility check](#)