

# Physicochemical Properties of Azecan-2-one (Caprinolactam): A Technical Guide

**Author:** BenchChem Technical Support Team. **Date:** April 2026

## Compound of Interest

Compound Name:	Azecan-2-one
CAS No.:	6142-53-6
Cat. No.:	B3427706

[Get Quote](#)

## Executive Summary

**Azecan-2-one** (commonly known as Caprinolactam or 2-Azacyclodecanone) is the 10-membered cyclic amide (lactam) derived from decanoic acid precursors.<sup>[1]</sup> Unlike the widely utilized

-caprolactam (6-membered, Nylon 6 precursor) and laurolactam (12-membered, Nylon 12 precursor), **azecan-2-one** occupies the "medium-ring" niche (8–11 atoms).<sup>[1]</sup> This structural positioning imparts unique physicochemical characteristics driven by transannular strain and conformational flexibility.

This guide provides a definitive technical profile of **azecan-2-one**, focusing on its thermodynamic behavior, synthesis via the Beckmann rearrangement, and utility as a monomer for Nylon 10 (Polyamide 10).

## Molecular Architecture & Conformational Dynamics

The 10-membered ring of **azecan-2-one** is characterized by significant transannular strain (Prelog strain), arising from the forced proximity of hydrogen atoms across the ring. Unlike

small rings (rigid) or large rings (flexible, behaving like linear chains), **azecan-2-one** exists in a dynamic equilibrium of conformers.[1]

- **Cis/Trans Isomerism:** A defining feature of medium-ring lactams (8- to 10-membered) is the existence of the amide bond in both cis and trans configurations.[1] In **azecan-2-one**, the trans isomer is often thermodynamically favored in solution, whereas the cis form may predominate in the crystal lattice to maximize intermolecular hydrogen bonding.
- **Ring Strain:** The enthalpy of polymerization ( ) is driven by the release of this ring strain. **Azecan-2-one** possesses moderate strain (approx. 3–5 kcal/mol), making its ring-opening polymerization (ROP) thermodynamically favorable but kinetically distinct from the highly strained caprolactam.[1]

## Physicochemical Profile

The following data consolidates experimental values and high-confidence predictive models for **azecan-2-one** (CAS: 6142-53-6).

### Table 1: Key Physicochemical Properties[2][3]

Property	Value / Description	Source/Notes
IUPAC Name	Azecan-2-one	
Common Names	Caprinolactam, 2-Azacyclodecanone, -Decanolactam	
CAS Number	6142-53-6	
Molecular Formula		
Molecular Weight	155.24 g/mol	
Physical State	Low-melting solid or liquid	Dependent on cis/trans ratio and purity.[1]
Melting Point	-2°C to +35°C	Pure trans-isomer is often liquid; cis-rich fractions crystallize higher.[1]
Boiling Point	95°C @ 5 mmHg	Extrapolates to approx. 260–270°C at atm pressure.[1]
Density	0.980 – 1.02 g/cm <sup>3</sup>	Standard liquid density for medium lactams.[1]
LogP (Octanol/Water)	1.51 – 2.30	Predicted.[1] More lipophilic than caprolactam (LogP ~-0.12).[1]
Solubility	Soluble in ethanol, benzene, chloroform.	Limited water solubility compared to smaller lactams.
Refractive Index		Estimated based on homologous series.[1]

## Synthesis: The Beckmann Rearrangement[4]

The primary industrial and laboratory route to **azecan-2-one** is the Beckmann Rearrangement of cyclodecanone oxime. This acid-catalyzed rearrangement inserts a nitrogen atom into the cyclic ketone framework.

## Experimental Protocol

- Oximation: Cyclodecanone is reacted with hydroxylamine hydrochloride ( ) in a buffered aqueous/alcoholic solution to yield cyclodecanone oxime.[1]
- Rearrangement: The oxime is treated with a strong acid catalyst (e.g., Polyphosphoric acid, Sulfuric acid, or Thionyl chloride) to induce ring expansion.
- Purification: The crude lactam is neutralized, extracted into an organic solvent (e.g., dichloromethane), and purified via vacuum distillation.

## Visualization: Synthesis Pathway

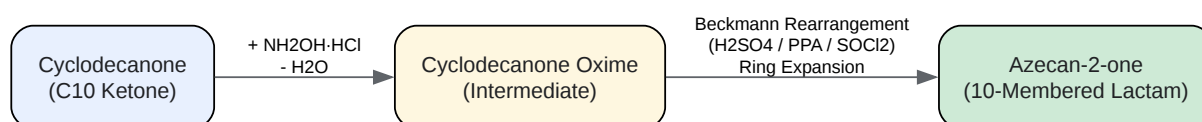

Figure 1: Synthesis of Azecan-2-one via Beckmann Rearrangement of Cyclodecanone Oxime.

[Click to download full resolution via product page](#)

## Polymerization: Route to Nylon 10

**Azecan-2-one** serves as the monomer for Nylon 10 (Polyamide 10).[1] Unlike Nylon 6,10 (a condensation polymer of sebacoyl chloride and hexamethylene diamine), Nylon 10 is a polylactam formed via Ring-Opening Polymerization (ROP).[1]

## Anionic Ring-Opening Polymerization (AROP)

The anionic route is preferred for its speed and ability to proceed at lower temperatures, minimizing side reactions.

Reagents:

- Initiator: Strong base (e.g., Sodium Caprolactamate, NaH, or Magnesium Bromide salts).[1]
- Activator: N-Acetyl caprolactam or Isocyanates (promotes rapid initiation).[1]

Mechanism:

- Initiation: The base deprotonates the lactam amide group, creating a nucleophilic lactam anion.
- Propagation: The anion attacks the carbonyl carbon of another lactam ring (or the activated N-acyl species), opening the ring and regenerating the anion at the chain end.
- Termination: Protonation or consumption of monomer.

## Visualization: Polymerization Mechanism

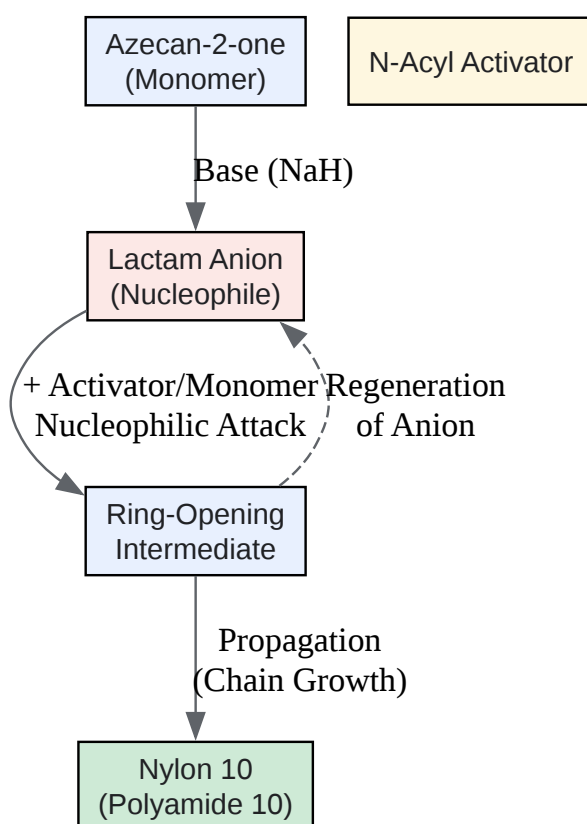

Figure 2: Anionic Ring-Opening Polymerization (AROP) of Azecan-2-one to Nylon 10.

[Click to download full resolution via product page](#)

[1]

## Applications & Comparative Analysis

Nylon 10 derived from **azecan-2-one** offers a specific balance of properties between Nylon 6 and Nylon 12.

- **Moisture Absorption:** Lower than Nylon 6 due to the higher carbon-to-amide ratio (9:1 vs 5:1), resulting in better dimensional stability in humid environments.[1]
- **Flexibility:** The longer methylene segments impart greater flexibility and impact resistance compared to Nylon 6.
- **Melting Point:** Nylon 10 typically melts around 188–190°C, which is lower than Nylon 6 (220°C) but higher than Nylon 12 (178°C), offering a useful processing window.[1]

## References

- National Center for Biotechnology Information (2026). PubChem Compound Summary for CID 70523, Azacycloundecan-2-one (Homolog Reference).[1] Retrieved from [Link][1]
- White Rose eTheses Online (2022). Successive Ring Expansion (SuRE) in the synthesis of medium sized ring and macrocycle libraries. (Contains experimental details on **azecan-2-one** synthesis). Retrieved from [Link]
- Polymer Science Learning Center. Polymerization of Nylon 6 and Nylon 6,10. (Contextual reference for AROP mechanisms). Retrieved from [Link][1]

### Need Custom Synthesis?

BenchChem offers custom synthesis for rare earth carbides and specific isotopic labeling.

Email: [info@benchchem.com](mailto:info@benchchem.com) or [Request Quote Online](#).

## Sources

- [1. US20030055152A1 - Flame-retardant thermoplastic composition with improved properties - Google Patents \[patents.google.com\]](#)

- To cite this document: BenchChem. [Physicochemical Properties of Azecan-2-one (Caprinolactam): A Technical Guide]. BenchChem, [2026]. [Online PDF]. Available at: [<https://www.benchchem.com/product/b3427706/docs#physicochemical-properties-of-azecan-2-one-caprinolactam-a-technical-guide>]

---

### Disclaimer & Data Validity:

The information provided in this document is for Research Use Only (RUO) and is strictly not intended for diagnostic or therapeutic procedures. While BenchChem strives to provide accurate protocols, we make no warranties, express or implied, regarding the fitness of this product for every specific experimental setup.

**Technical Support:** The protocols provided are for reference purposes. Unsure if this reagent suits your experiment?

**Need Industrial/Bulk Grade?** [Request Custom Synthesis Quote](#)

## BenchChem

Our mission is to be the trusted global source of essential and advanced chemicals, empowering scientists and researchers to drive progress in science and industry.

### Contact

Address: 3281 E Guasti Rd  
Ontario, CA 91761, United States  
Phone: (601) 213-4426  
Email: [info@benchchem.com](mailto:info@benchchem.com)

[Contact our Ph.D. Support Team for a compatibility check](#)