

Troubleshooting poor separation of 4-MCHM in reverse-phase HPLC

Author: BenchChem Technical Support Team. **Date:** May 2026

Compound of Interest

Compound Name: (4-Methylcyclohexyl)methanol

CAS No.: 3937-49-3

Cat. No.: B3425148

[Get Quote](#)

Technical Support Hub: 4-MCHM Separation & Analysis

Topic: Troubleshooting Poor Separation of 4-MCHM in Reverse-Phase HPLC
Role: Senior Application Scientist
Status: Active Support Session

Executive Summary: The 4-MCHM Challenge

You are likely encountering one of three critical failures: (1) Non-detection (flat baseline), (2) Co-elution (single broad peak instead of two isomer peaks), or (3) Retention drift.

4-Methylcyclohexanemethanol (4-MCHM) is deceptively simple. It is an alicyclic alcohol with no conjugated

-system, rendering it nearly invisible to standard UV detection (254 nm). Furthermore, it exists as two geometric isomers (cis and trans) with distinct physicochemical properties but similar hydrophobicity.^[1]

This guide provides a self-validating troubleshooting workflow to resolve these issues, pivoting from standard environmental GC-MS methods to a robust HPLC protocol.

Part 1: Diagnostic Workflow

Before modifying your method, identify your specific failure mode using this logic tree.

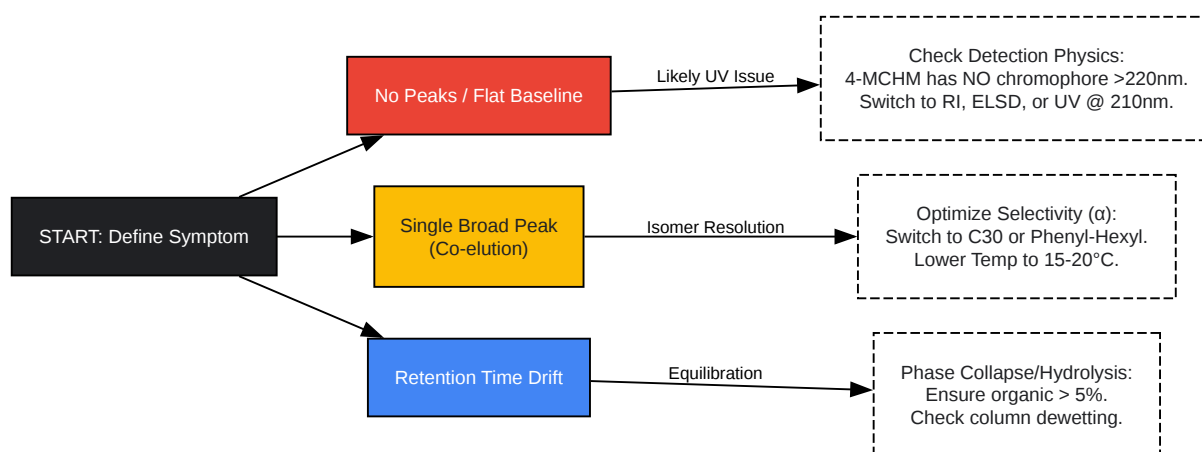

[Click to download full resolution via product page](#)

Figure 1: Diagnostic logic tree for isolating 4-MCHM separation failures.

Part 2: Troubleshooting Guides (Q&A)

Module A: The "Invisible" Analyte (Detection Issues)

Q: I am injecting 1 mg/mL of standard but seeing nothing at 254 nm. Is my column dead? A: Your column is likely fine; your detector wavelength is the problem. 4-MCHM is a saturated alcohol. It lacks the conjugated double bonds required to absorb UV light in the standard aromatic region (254–280 nm).

- The Fix: You must rely on the sigma-bond transitions, which occur in the far UV region.
 - Wavelength: Set your UV detector to 210 nm.

- Solvent Cutoff: You must use HPLC-grade Acetonitrile (UV cutoff ~190 nm). Avoid Methanol if possible, as it absorbs significantly at 210 nm, causing baseline noise that masks the analyte.
- Alternative Detectors: If available, use a Refractive Index (RI) detector or Evaporative Light Scattering Detector (ELSD). These are "universal" detectors and ignore the lack of chromophore.

Q: I switched to 210 nm, but now my baseline is drifting wildly. Why? A: At 210 nm, you are detecting the mobile phase itself.

- Impurity Amplification: Any impurities in your water or organic modifier are now visible. Use LC-MS grade water and solvents.
- Gradient Ghosting: If running a gradient, the changing refractive index and absorbance of the mixing solvents will cause a "hump" in the baseline.
- Solution: Switch to an isocratic method (constant mobile phase composition) to flatten the baseline.

Module B: Isomer Resolution (Separating Cis/Trans)

Q: I see one peak. How do I separate the cis and trans isomers? A: You need to maximize "Shape Selectivity." While the isomers have different hydrophobicity (Log

), the difference is small. The trans isomer is generally flatter and more linear, while the cis isomer is more "bent."

- Scientific Insight: Standard C18 columns separate based on hydrophobicity.[2] To separate based on shape, you need a stationary phase that orders itself rigidly, allowing it to discriminate between the linear trans and bulky cis forms.
- The Fix:
 - Column Substitution: Replace standard C18 with a C30 (Triacontyl) or Phenyl-Hexyl column. These provide superior steric selectivity.

- Temperature Control: Lower your column temperature. Higher temperatures increase molecular motion, blurring the subtle steric differences. Run at 15°C or 20°C, not 40°C.

Q: Which isomer elutes first? A: In Reverse-Phase HPLC, the Cis isomer elutes first.

- Mechanism: The cis isomer is more polar (Log P ~-2.35) and has a higher water solubility compared to the trans isomer (Log P ~-2.46) [1, 2]. Therefore, cis interacts less with the hydrophobic stationary phase and travels faster.

Part 3: Validated Experimental Protocol

This protocol is designed to resolve isomers using standard RP-HPLC equipment.

Table 1: HPLC Method Parameters

Parameter	Setting	Rationale
Column	C18 (High Carbon Load) or C30	High carbon load increases phase ratio (), improving resolution.
Dimensions	250 mm x 4.6 mm, 5 μm	Longer column length () increases theoretical plates ().
Mobile Phase	Acetonitrile : Water (60 : 40)	Isocratic elution prevents baseline drift at low UV.
Flow Rate	1.0 mL/min	Standard flow for 4.6mm ID.[4]
Detection	UV @ 210 nm	Mandatory for 4-MCHM detection (or use RI/ELSD).
Temperature	20°C	Low temperature enhances shape selectivity.
Injection Vol	10–20 μL	High volume compensates for low UV sensitivity.

Step-by-Step Optimization Workflow

- **System Suitability:** Inject a blank (mobile phase). Ensure the baseline at 210 nm is stable (< 0.5 mAU drift/min).
- **Standard Injection:** Inject a 1000 ppm mix of 4-MCHM.
- **Peak Identification:**
 - **First Peak:** cis-4-MCHM (Minor/Major depending on source, usually ~30-40%).
 - **Second Peak:** trans-4-MCHM (Later eluting due to higher hydrophobicity).
- **Resolution Check:** Calculate Resolution (

).

- If `ngcontent-ng-c3230145110="" _ngghost-ng-c1768664871="" class="inline ng-star-inserted">`

: Decrease % Acetonitrile by 5% increments. This increases retention time (

) and generally improves resolution.

Part 4: Advanced Method Development (Graphviz)

Use this workflow if the standard protocol fails to achieve baseline resolution.

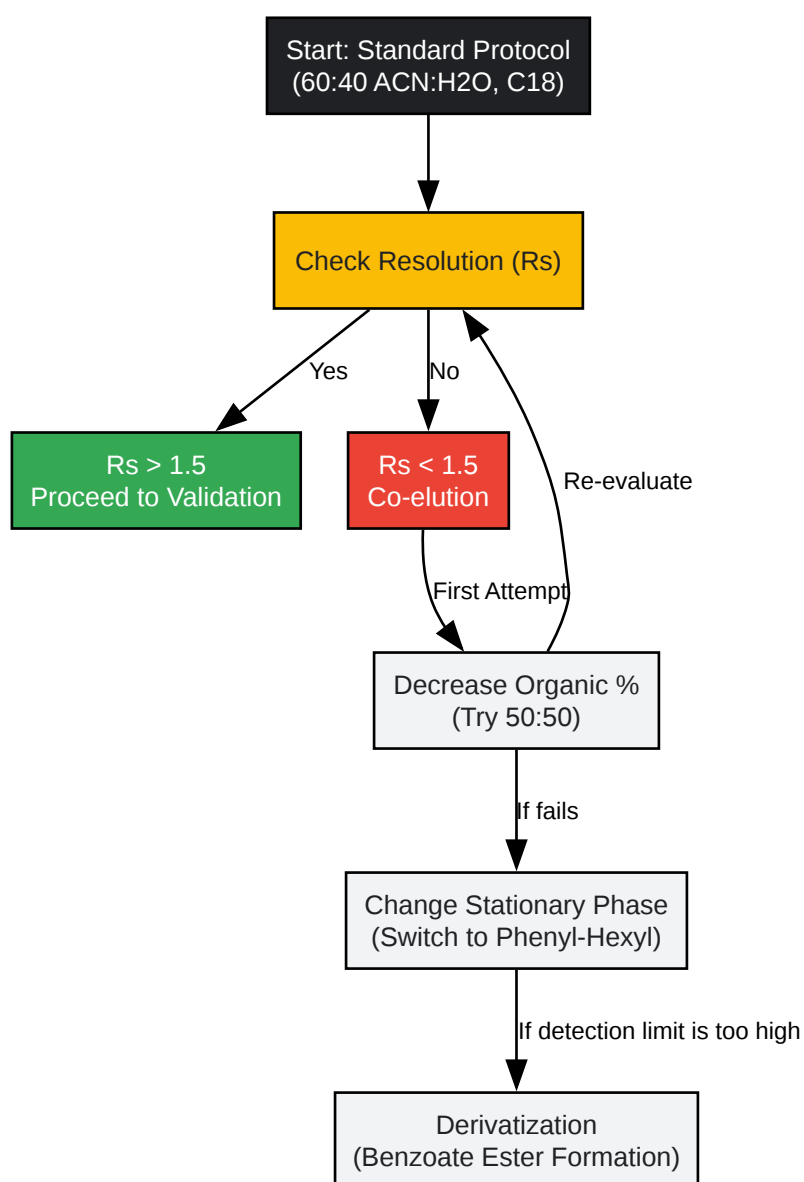

[Click to download full resolution via product page](#)

Figure 2: Advanced optimization strategy for difficult matrices.

References

- Phetxumphou, K., et al. (2016). "Partitioning, Aqueous Solubility, and Dipole Moment Data for cis- and trans-(**4-Methylcyclohexyl**)methanol, Principal Contaminants of the West Virginia Chemical Spill." Environmental Science & Technology. Available at: [[Link](#)]
- Foreman, W. T., et al. (2015).[5] "Determination of (**4-methylcyclohexyl**)methanol isomers by heated purge-and-trap GC/MS in water samples from the 2014 Elk River, West Virginia, chemical spill." Chemosphere.[5] Available at: [[Link](#)]
- USGS. (2014).[3] "Methods of Analysis by the U.S. Geological Survey Organic Geochemistry Research Group." USGS Technical Notes. Available at: [[Link](#)]

Need Custom Synthesis?

BenchChem offers custom synthesis for rare earth carbides and specific isotopic labeling.

Email: info@benchchem.com or [Request Quote Online](#).

Sources

- 1. pdf.benchchem.com [pdf.benchchem.com]
- 2. documents.thermofisher.com [documents.thermofisher.com]
- 3. researchgate.net [researchgate.net]
- 4. HPLC Method for Analysis of Hydroquinone and 4-Methoxyphenol (Mequinol) on Primesep 100 Column | SIELC Technologies [sielc.com]
- 5. Sci-Hub. Determination of (4-methylcyclohexyl)methanol isomers by heated purge-and-trap GC/MS in water samples from the 2014 Elk River, West Virginia, chemical spill / Chemosphere, 2015 [sci-hub.jp]
- To cite this document: BenchChem. [Troubleshooting poor separation of 4-MCHM in reverse-phase HPLC]. BenchChem, [2026]. [Online PDF]. Available at: [<https://www.benchchem.com/product/b3425148/docs#troubleshooting-poor-separation-of-4-mchm-in-reverse-phase-hplc>]

Disclaimer & Data Validity:

The information provided in this document is for Research Use Only (RUO) and is strictly not intended for diagnostic or therapeutic procedures. While BenchChem strives to provide accurate protocols, we make no warranties, express or implied, regarding the fitness of this product for every specific experimental setup.

Technical Support: The protocols provided are for reference purposes. Unsure if this reagent suits your experiment?

Need Industrial/Bulk Grade? [Request Custom Synthesis Quote](#)

BenchChem

Our mission is to be the trusted global source of essential and advanced chemicals, empowering scientists and researchers to drive progress in science and industry.

Contact

Address: 3281 E Guasti Rd
Ontario, CA 91761, United States
Phone: (601) 213-4426
Email: info@benchchem.com

[Contact our Ph.D. Support Team for a compatibility check](#)